

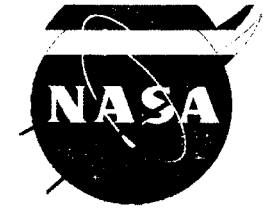

# TIMED

*Thermosphere • Ionosphere • Mesosphere • Energetics and Dynamics  
Flight Operations Review*



## AGENDA

Morning, November 8, 2000, Room 4-275

				Page
Mission Overview	Kusnierkiewicz	30 Minutes	8:30 - 9:00 am	10
Spacecraft Modes	Packard	15	9:00 - 9:15	34
S/C & Instrument Ops Constraints	Boie	10	9:15 - 9:25	44
On-Board Memory Mgmt	Boie	10	9:25 - 9:35	50
Flight S/W Status & Maintenance	Chu	10	9:35 - 9:45	55
Ground System Block Diagram/ Verification Matrix	Rodberg	20	9:45 - 10:05	60
Ground System S/W Overview & Status	Rodberg/Knopf	20	10:05 - 10:25	96
<b>BREAK</b>		<b>10</b>	<b>10:25 - 10:35</b>	
Ground System Interfaces (POCs, USN, TDRSS)	Rodberg	30	10:35 - 11:05	66
MOT Status	Grant	10	11:05 - 11:15	106
Training/MOC S/C Contingencies	Dragonette	30	11:15 - 11:45	111
Ground System Contingencies	Rodberg	10	11:45 - 11:55	141
Documentation Status	Knopf	15	11:55 - 12:10pm	151
<b>LUNCH</b>		<b>50</b>	<b>12:10 - 1:00</b>	



# TIMED

*Thermosphere • Ionosphere • Mesosphere • Energetics and Dynamics  
Flight Operations Review*

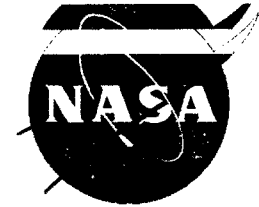

---

## AGENDA

Afternoon, November 8, 2000, Room 4-275

### POC Status

				Page
SABER	Grube	60 Minutes	1:00 - 2:00 pm	156
SEE	Tate, Woodraska	60	2:00 - 3:00	186
<b>BREAK</b>		<b>15</b>	<b>3:00 - 3:15</b>	
TIDI	Gell	60	3:15 - 4:15	232
GUVI	Ogorzalek	60	4:15 - 5:15	274



# TIMED

*Thermosphere • Ionosphere • Mesosphere • Energetics and Dynamics  
Flight Operations Review*

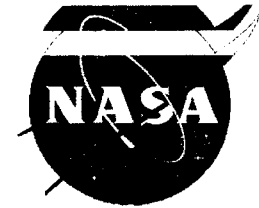

## AGENDA

November 9, 2000, Room 4-275

				Page
Testing Summary	Packard	55 Minutes	8:30 - 9:25 am	301
Mission Readiness	Knopf	15	9:25 - 9:40	322
<b>LEOPS Support</b>				
APL Ground Station	Dragonette	10	9:40 - 9:50	333
USN	Dragonette	10	9:50 - 10:00	
HBK	Dragonette	5	10:00 - 10:05	
TDRSS	Dragonette	10	10:05 - 10:15	
<b>BREAK</b>		<b>15</b>	<b>10:15 - 10:30</b>	
Launch Critical Facilities and Functions	Knopf	10	10:30 - 10:40	344
Personnel Assignments	Knopf	15	10:40 - 10:55	348
Remaining Work & it's Criticality	Knopf	15	10:55 - 11:05	363

# TIMED *Delta* Mission Ops Review



November 8, 2000

The Johns Hopkins University Applied Physics Laboratory

TIMED Flight Operations Review

Topic	Presenter	Time	Duration (min)
<b>Day 1: 11/08/2000</b>			
<b>Introduction</b>	Kusnierkiewicz	8:00 AM	30
Objectives			
Mission, S/C, and Instrument Overview			
TIMED CONOPS Overview			
<i>Decoupled Operations</i>			
<i>Event Based Commanding</i>			
<i>Remote POCS, etc.</i>			
<i>Test Time on System in Flight Configuration</i>			
New Requirements and Changes in Plans			
<b>Operations Review</b>			
S/C Modes	Packard	8:30 AM	15
S/C and Instrument Ops Constraints	Boie	8:45 AM	10
On-Board Data Memory Management	Boie	8:55 AM	10
Flight S/W Status and Maintenance	Chu	9:05 AM	10
<b>Ground System Review</b>			
Ground System Block Diagram	Rodberg	9:30 AM	10
Ground System Verification Matrix	Rodberg	9:40 AM	20
S/W Overview and Status	Knopf/Rodberg	10:00 AM	20
Ground System Interfaces			
<i>POCs</i>	Rodberg	10:20 AM	10
<i>USN</i>	Rodberg	10:30 AM	10
<i>TDRSS</i>	Rodberg	10:40 AM	10
<<<< BREAK >>>>		10:50 AM	10
MOT Status			
<i>Staffing Plans through Phase E</i>	Grant	11:00 AM	10
Training Plans	Dragonette	11:10 AM	15
Contingencies			
<i>MOC S/C Contingency Procedures</i>	Dragonette	11:25 AM	15
<i>Ground System Contingencies</i>	Rodberg	11:40 AM	10
Documentation Status			
<i>MOC Documents</i>	Knopf	11:50 AM	5
<i>ICD Status</i>	Knopf	11:55 AM	5
<i>Database and Procedure Status</i>	Knopf	12:00 PM	5
<<<< Lunch >>>>		12:05 PM	55

TIMED Flight Operations Review

<b>POC Status</b>	All POCs	1:00 PM	240	
Hardware Status				
	<i>POC/MOC Interfaces</i>			
Software Status				
Operations				
	<i>Launch and Early Ops</i>			
	<i>Normal</i>			
	<i>Contingency</i>			
	<i>Operations Planning with MOC</i>			
Monitoring				
	<i>Telemetry and Assessment</i>			
	<i>Trending</i>			
	<i>Alarm and Safing Parameters</i>			
Science Data Processing and Analysis				
<b>Day 2: 11/09/2000</b>				
<b>Test Summary</b>				
Test Descriptions and Schedule	Packard	8:30 AM	15	
	<i>Tests to Date</i>	8:45 AM	15	
	<i>Pre-Launch Test Plans</i>	9:00 AM	15	
	<i>Launch Site and Pad Tests</i>	9:15 AM	10	
Mission Readiness	Knopf	9:25 AM	15	
<b>LEOPS Support</b>				
APL Ground Station	Dragonette	9:40 AM	10	
USN	Dragonette	9:50 AM	10	
HBK	Dragonette	10:00 AM	5	
TDRSS	Dragonette	10:05 AM	10	
Launch Critical Facilities and Functions	Knopf	10:15 AM	10	
Personnel Assignments	Knopf	10:25 AM	10	
	<i>Personnel Location During Launch and Early Ops</i>	10:35 AM	5	
Decision Flow Management Diagram for LEOPS	Kusnierkiewicz	10:40 AM	10	
	<i>&lt;&lt;&lt;&lt; BREAK &gt;&gt;&gt;&gt;</i>	10:50 AM	15	
<b>RFA/PFR Updates</b>				
RFA Status from Previous FOPS Review	Knopf	11:05 AM	10	
PFRs	Kusnierkiewicz	11:15 AM	15	
<b>Issues and Concerns</b>				
	<i>Remaining Work and it's Criticality</i>	Knopf	11:30 AM	15

## ACRONYMS

AFC	Attitude Flight Computer	ECI	Earth-centered Inertial
AGC	Automatic Gain Control	EDL	Epoch Display Language
AIU	Attitude Interface Unit	EDMS	Event-driven Mission Simulation
AOS	Acquisition of Signal	EEPROM	Electronic Erasable Programmable Read Only Memory
APID	Application Packet Identifier	EGS	EUV Grating Spectrograph
APL	Applied Physics Laboratory	ELSET	Element Set
ARR	Authentication Return Receipt	EM	Engineering Model
ASIC	Application Specific Integrated Circuit	EU	Engineering Units
AST	Autonomous Star Tracker	EUI	Epoch User Interface
BB	Baseband	EUV	Extreme Ultraviolet
BC	Bus Controller	FEP	Front-end Processor
BCU	Blockhouse Control Unit	FF	Flatfile
BUILDTLM	Build Telemetry Program	FTP	File Transfer Protocol
CCSDS	Consultative Committee for Space Data Systems	FWSHUTTLE	Firewall Shuttle
CDR	Critical Design Review	G&C	Guidance and Control
CFO	Command Frame Output	GB	Gigabytes
CFS	CCSDS Frame Sync	GNS	GPS Navigation System
CLCW	Command Link Control Word	GPS	Global Positioning System
CMD	Command	GS	Ground Station
CMDIF	Command Interface	GSE	Ground Support Equipment
CMP	Composite File	GUI	Graphical User Interface
COP-1	Command Operations Protocol 1	GUVI	Global Ultra-violet Imager
COTS	Commercial Off-the-shelf	H&S	Health and Status
CRR	Command Return Receipt	HWCNTRL	Hardware Control
CSV	Comma Separated Value	HWREMOTE	Hardware Remote
CUC	CCSDS Unsegmented Time Code	I/O	Input/Output
CV	Command Verification	IEM	Integrated Electronics Module
DOD	Depth of Discharge	IRU	Inertial Reference Unit
D/L	Downlink	ISI	Integral Systems Incorporated
ECEF	Earth-centered, Earth-fixed	ITT	Integration and Test Team

## ACRONYMS

JHU	Johns Hopkins University	R/T	Real-time
LEO-T	Low Earth Orbit – Tracking Station	RAID	Redundant Array of Independent Drives
LIM	Laser Intensity Monitor	RAM	Random Access Memory
LOS	Loss of Signal	RCS	Revision Control System
LVS	Low Voltage Sensing	REV	Revision
LVSMS	Low Voltage Sensing Mission Simulation	REV	Revolution
MAX	Maximum	RF	Radio Frequency
MAX	Memory Allocation Examiner (software)	RFGSE	RF Ground Support Equipment
MDC	Mission Data Center	RIU	Remote Interface Unit
MIN	Minimum	RT	Remote Terminal
MOC	Mission Operations Center	SA	Solar Array
MOR	Mission Operations Review	S/C	Spacecraft
MOT	Mission Operations Team	SA	Selective Availability
MPCF	MOC-POC Command Filter	SAA	South Atlantic Anomaly
MS	Microsoft	SABER	Sounding of the Atmosphere using Broadband Emission Radiometry
NP	Navigation Processor	SAS	Solar Array Simulator
NT	Microsoft Windows New Technology	SBET	Spacecraft Bus Engineering Team
ODC	Observational Description Command	SCHEDD	Scheduler Daemon software
P/B	Playback	SEE	Solar EUV Experiment
PAM	Parameter Archive Module	SET	Spacecraft Engineering Team
POC	Payload Operations Center	SSPP	SEE Solar Pointing Platform
PPT	Peak Power Tracking	SSR	Solid State Recorder
PROCC	Processor Compare Software	SSS	Front End Buildtm Program
PROCD	Processor Dump Software	ST	Star Tracker
PROCL	Processor Load Software	STK	Satellite Tool Kit
PSE/DU	Power System Electronics/Distribution Unit	STOL	Satellite Test and Operation Language
PSK	Phase Shift Keying	SV	Space Vehicle (GPS)
PVAT	Position, Velocity, Attitude, Time	SV	Storage Variable
PVT	Position, Velocity, Time	SWG	Science Working Group
QL (Q/L)	Quick-look	S/W	Software



## ACRONYMS

TASTIE	TIMED Attitude Test And Integration Equipment
TBD	To Be Determined
TCP/IP	Transfer Control Protocol/Internet Protocol
TDRSS	Tracking Data Relay Satellite System
TFI	Telemetry Fame Input
TIDI	TIMED Doppler Interferometer
TIMED	Thermionic, Ionosphere, Mesosphere, Energetics and Dynamics
TINTS	TIMED Integration Simulator
TLM	Telemetry
TLMIF	Telemetry Interface
TP	Tracking Processor
TTF	Time to First Fix
TOPS	TIMED Operations Simulator
TSS	Telemetry Subset Service
TVI	Telemetry Virtual Input
USN	Universal Space Network
UTC	Universal Time Coordinated
U/L	Uplink
VC	Virtual Channel
V/T (V-T)	Voltage/Temperature
WS	Work Station
XMIT	Transmit
XPS	XUV Photometer System
XUV	X-ray Ultraviolet



# ***TIMED***

*Thermosphere • Ionosphere • Mesosphere • Energetics and Dynamics  
Flight Operations Review*

---

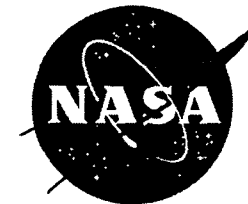

## **Flight Ops Review**

**November 8-9, 2000**

**David Y. Kusnierkiewicz**  
**TIMED Mission System Engineer**

**The Johns Hopkins University  
Applied Physics Lab  
11100 Johns Hopkins Road  
Laurel, MD 20723-6099  
240-228-5092  
david.kusnierkiewicz@jhuapl.edu**

DYK-1



# ***TIMED***

*Thermosphere • Ionosphere • Mesosphere • Energetics and Dynamics  
Flight Operations Review*

---



## **Flight Ops Review Objectives**

- **To present the readiness of the TIMED Mission Operations and Ground System to support flight operations**



# ***TIMED***

*Thermosphere • Ionosphere • Mesosphere • Energetics and Dynamics  
Flight Operations Review*

---



## **TIMED Mission Overview**

- **TIMED is an atmospheric remote sensing mission sponsored by the NASA Office of Space Science; TIMED is the first *Solar Connections* program**
- **TIMED is a two-year mission intended to launch in March 2001 on a Delta II co-manifested with JASON**
- **TIMED will launch into a 625-km circular orbit inclined 74.1° with a 720° per year nodal regression**
- **The four TIMED instruments (GUVI, SABER, SEE, and TIDI) operate on a 100% duty-cycle**
- **The TIMED instruments, spacecraft and ground system incorporate advanced autonomy features and use a decoupled operations concept intended to lower the cost of Mission Operations and Data Analysis**



# TIMED

*Thermosphere • Ionosphere • Mesosphere • Energetics and Dynamics  
Flight Operations Review*



## TIMED Spacecraft

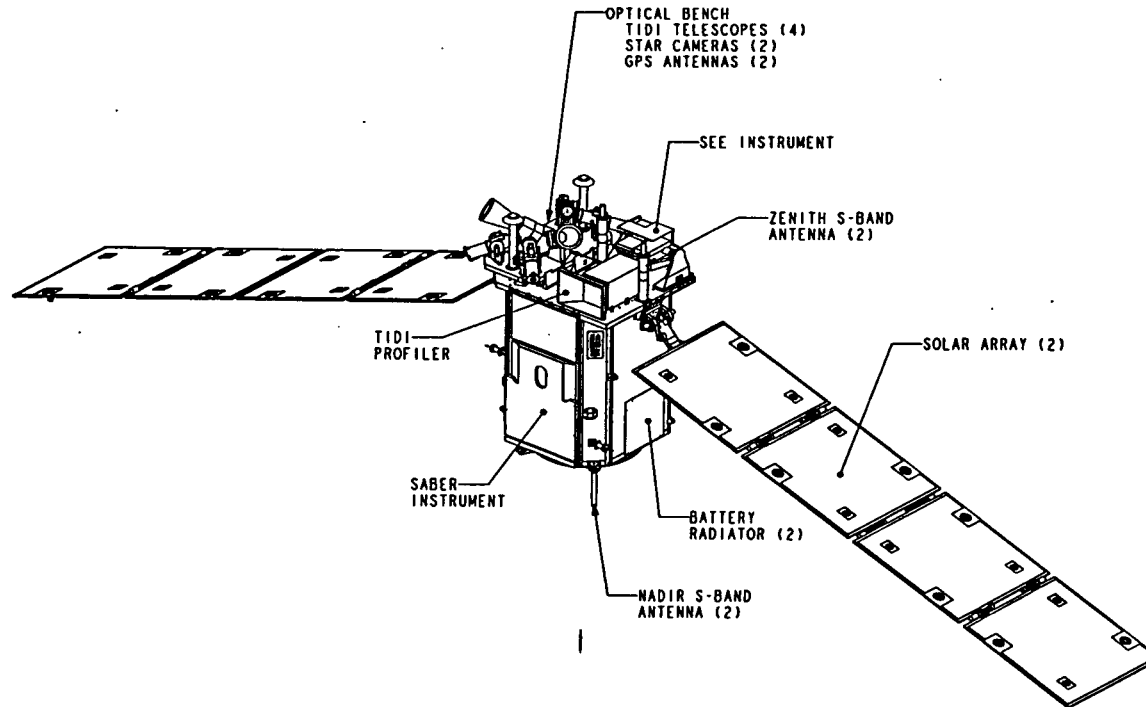

DYK-4



# TIMED

Thermosphere • Ionosphere • Mesosphere • Energetics and Dynamics  
Flight Operations Review



## Spacecraft Block Diagram

TIMED BLOCK DIAGRAM

 = Procured Component

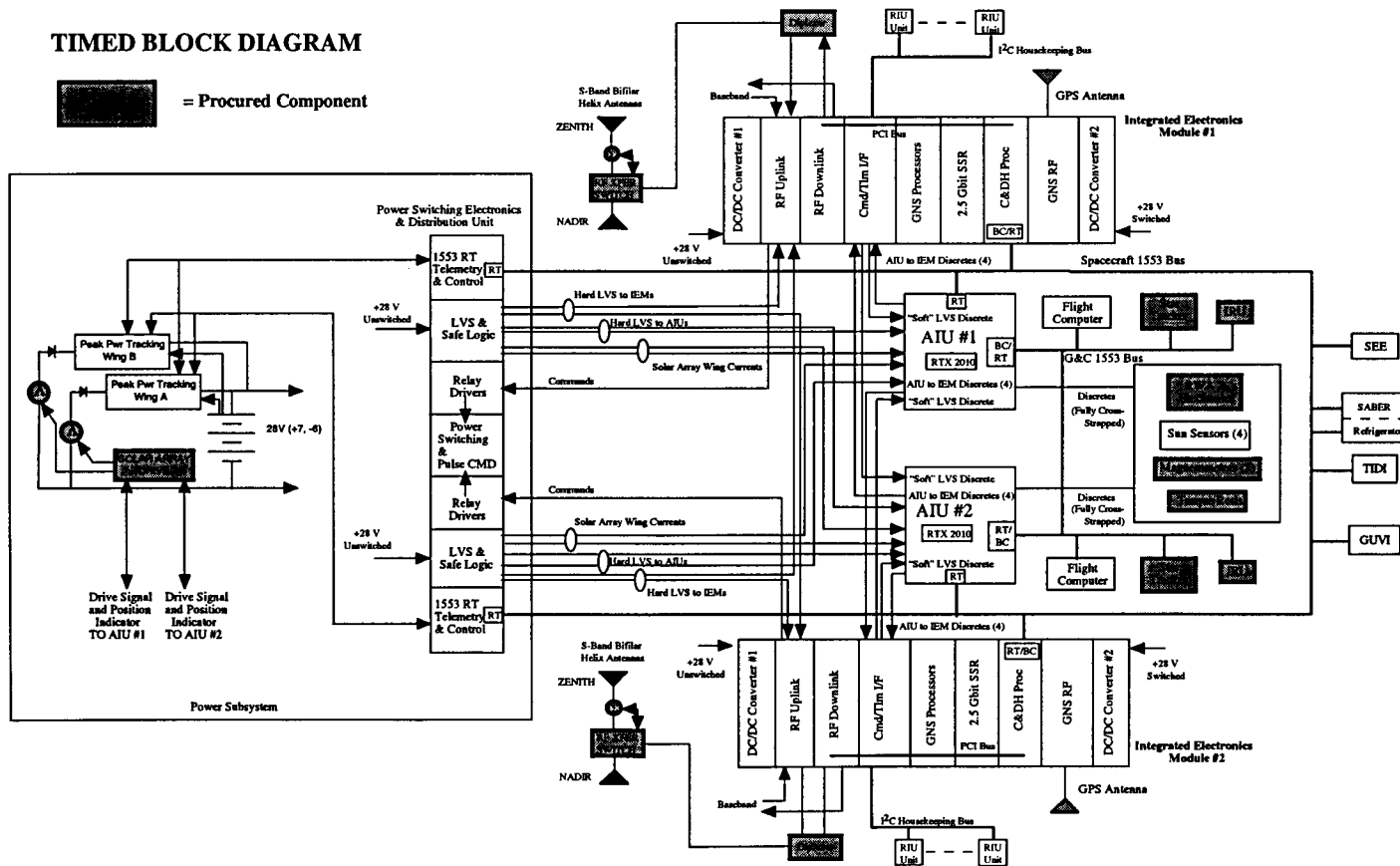



# *TIMED*

*Thermosphere • Ionosphere • Mesosphere • Energetics and Dynamics  
Flight Operations Review*

---



## **Spacecraft Description**

- **Aluminum Structure, Al Honeycomb Panels**
  - **Composite Optical Bench for TIDI, Star Cameras**
  - **Aluminum Face Sheets on Solar Panels**
- **Three Axis stabilized; no propulsion**
  - **One side of spacecraft always cold (180° yaw maneuver every 60 days)**
- **On-board Autonomous GPS Navigation**
- **S-Band Communications**
- **Two solar panel wings (GaAs Cells) with single axis drive**
- **22 cell Individual Pressure Vessel Nickel Hydrogen battery**
- **Most Spacecraft relay commands executable without software through Critical Command Decoder (CCD, located on Uplink Card in IEM; always powered)**



# TIMED

*Thermosphere • Ionosphere • Mesosphere • Energetics and Dynamics  
Flight Operations Review*

---



## Spacecraft Description (Cont'd)

- Fully redundant spacecraft bus (Both Star Trackers Needed to meet Attitude Knowledge Requirement)
- Two 1553 Bus Architecture (Similar to NEAR)
  - C&DH/Spacecraft 1553 Bus
  - G&C 1553 Bus
    - AIUs are RTs on C&DH 1553, BC/RT for G&C 1553
    - AIUs are responsible for safing spacecraft
- Instruments are on C&DH 1553 Bus
  - Instrument Discretes Only for S/C Monitored Temperatures
    - Interface through RIUs
  - Each IEM is a single-string C&DH processor, 2.5 Gbit SSR, GPS Navigation System (GNS), and RF Communications “Subsystem” (Similar to ACE)
  - No Discrete (non-1553) Cross-Strapping Between IEMs





# ***TIMED***

*Thermosphere • Ionosphere • Mesosphere • Energetics and Dynamics  
Flight Operations Review*

---



## **Spacecraft States**

- **Operational (normal state)**
  - Attitude controlled to 0.5 deg, each axis, 3 sigma
  - Normal science data collection
  - 4Mbps downlink capability, nadir antenna
  
- **Nadir pointing**
  - Attitude controlled to 5 deg, each axis, 3 sigma
  - Instruments still collecting science data, but attitude & science data flagged as invalid
  - 4 Mbps downlink capability, nadir antenna
  
- **Safe Mode**
  - -Y axis to sun, solar panels turned to sun
  - SEE off, other instruments powered but safed
  - 10Kbps downlink capability, “omni” antenna configuration



# TIMED

*Thermosphere • Ionosphere • Mesosphere • Energetics and Dynamics  
Flight Operations Review*



## TIMED Instruments

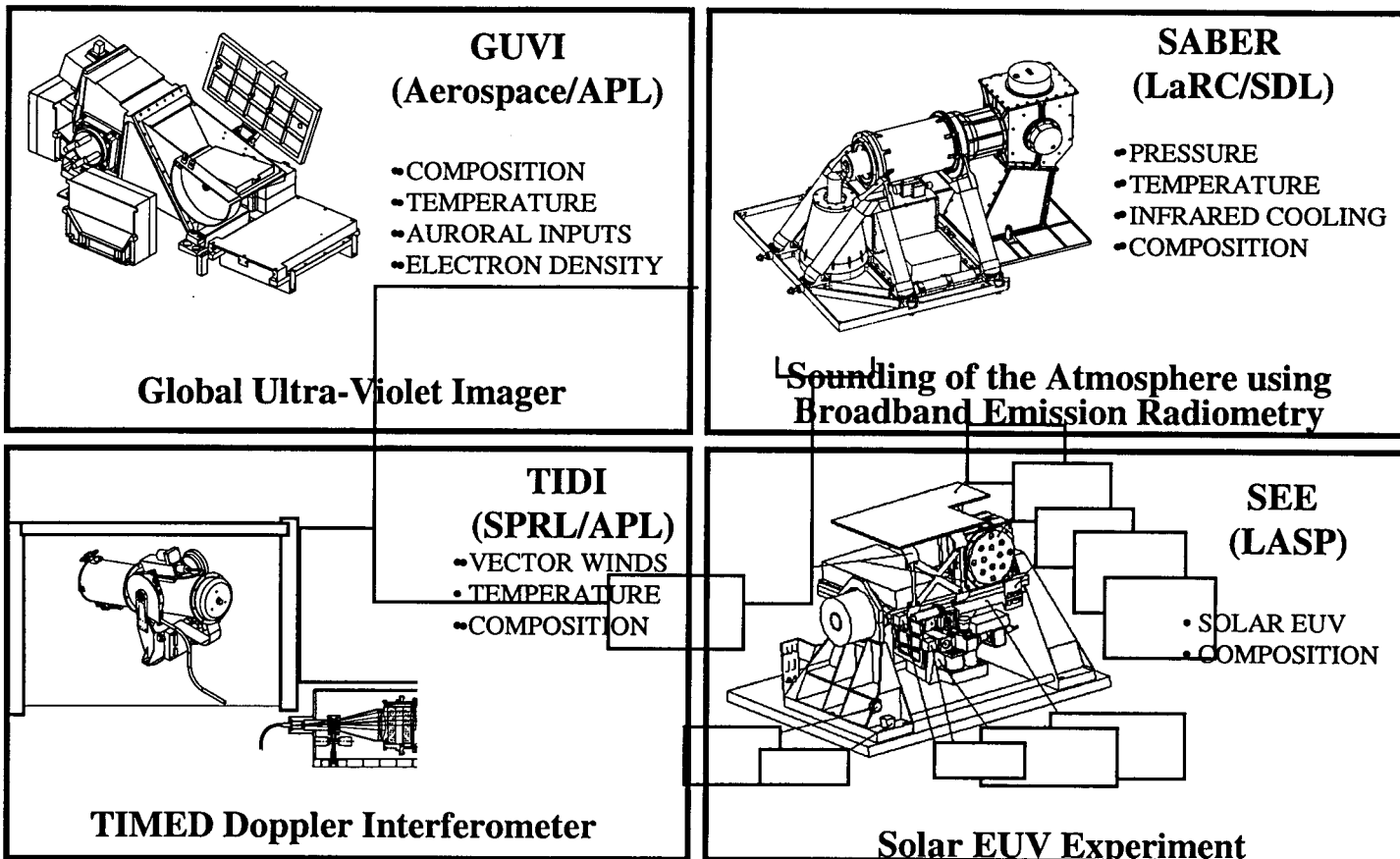



# ***TIMED***

*Thermosphere • Ionosphere • Mesosphere • Energetics and Dynamics  
Flight Operations Review*

---



## **Mission Operations Requirements**

- **The Mission Operations Segment is required to:**
  - **Plan and execute effective Mission operations in accordance with the science objectives of the TIMED program**
  - **Command the spacecraft from launch to the end of mission**
  - **Collect, process, and transmit commands from the TIMED instrument Payload Operations Centers to the instruments**
  - **Collect all raw telemetry**
  - **Process all spacecraft health and status telemetry data and maintain the spacecraft**
  - **Assess spacecraft performance and adapt operations to changes**
  - **Collect all science data for processing and distribution to POCs**
  - **Maintain command and TM dictionaries during the flight phase**



# TIMED

*Thermosphere • Ionosphere • Mesosphere • Energetics and Dynamics  
Flight Operations Review*

---



## Daily Operations Requirements

- **The primary TIMED Ground Station shall be selected to keep operations costs low**
- **The TIMED Ground Station shall have a backup**
- **Pass times shall be selected to keep operations costs low**
- **Spacecraft command uploads shall be prepared at the Mission Operations Center**
- **Instrument command uploads shall be prepared at the Payload Operations Centers and forwarded to the Mission Operations Center on a daily basis**



# TIMED

*Thermosphere • Ionosphere • Mesosphere • Energetics and Dynamics  
Flight Operations Review*



---

## Reducing Operations Costs (from CDR)

- **Post-launch MO&DA cost is dominated by staffing costs; to save on MO&DA, you must cut out people**
- **For TIMED, choices were early on made to save MO&DA costs without degrading science goals:**
  - **All operations will use a single shift of operators each day**
    - » **All operations are essentially daytime-only (6 AM to 6 PM)**
  - **Time-consuming analytical functions (orbit determination and propagation, attitude determination) are automated on-board**
  - **A common ground system will be used for I&T and MO&DA**
  - **The Ground System will incorporate autonomy to the greatest extent possible within the limits of reason and cost efficiency**
  - **Instrument and spacecraft operations will be decoupled to reduce the overhead associated with resolving resource conflicts; TIMED will use a unique ops concept to save on MO&DA costs**



# TIMED

Thermosphere • Ionosphere • Mesosphere • Energetics and Dynamics  
Flight Operations Review



## Ground System Architecture

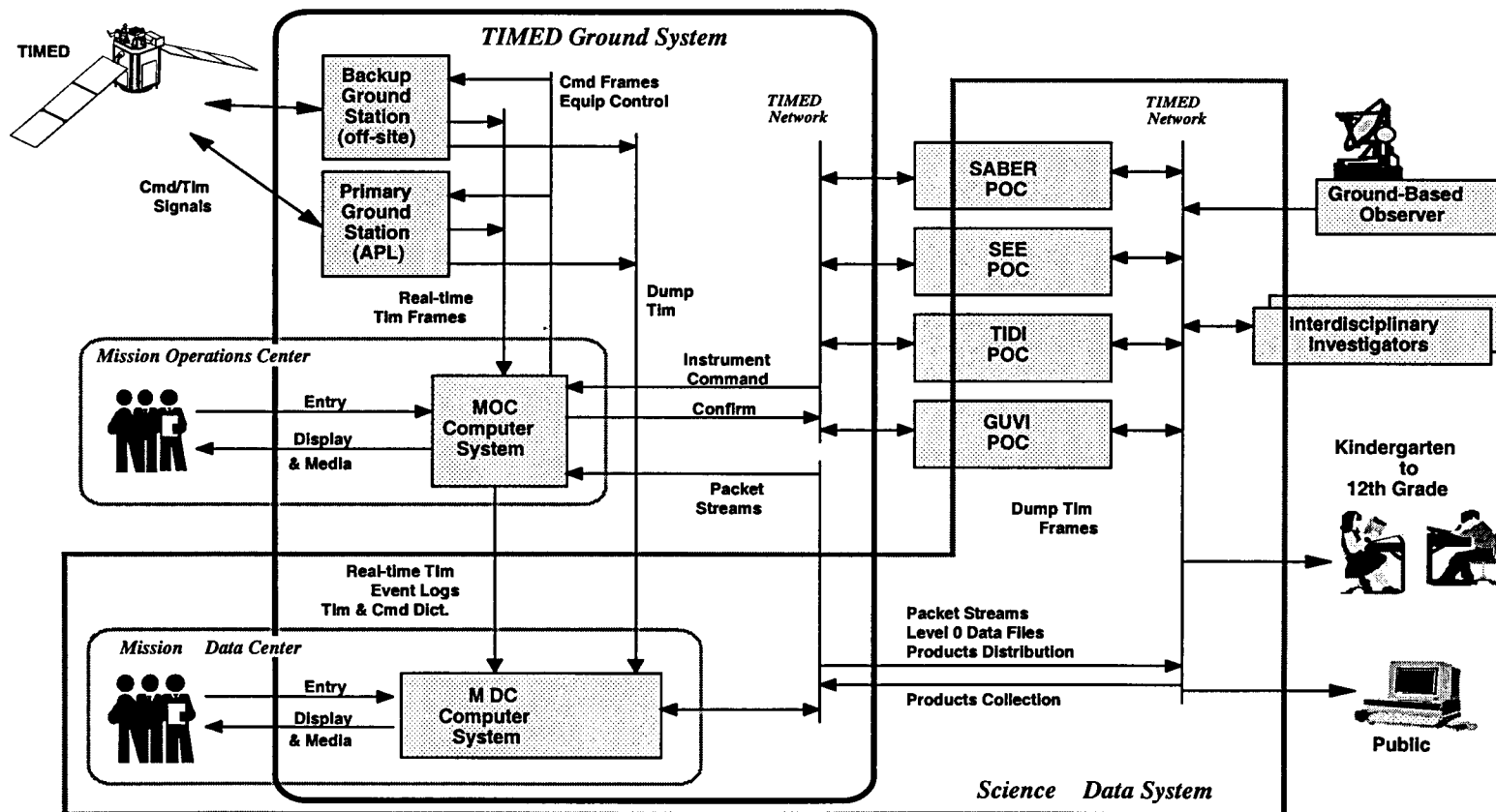

PJG, Rev h, 10-31-97



# ***TIMED***

*Thermosphere • Ionosphere • Mesosphere • Energetics and Dynamics  
Flight Operations Review*

---



## **TIMED Mission Operations Concept**

- **TIMED spacecraft has a high degree of autonomy to enable inexpensive Mission Operations with a small Mission Operations Team**
  - **Greyhound™ Bus Paradigm**
    - **Spacecraft is the “bus”, instruments are the “passengers”**
    - **Instrument operations are “decoupled” from spacecraft operations**
    - **Spacecraft provides sufficient resources for unconstrained, independent instrument operations**



# TIMED

*Thermosphere • Ionosphere • Mesosphere • Energetics and Dynamics  
Flight Operations Review*



## TIMED Mission Operations Concept (cont'd)

- **Mission Ops Team (MOT) is responsible for operating spacecraft from the Mission Operations Center (MOC)**
  - **Real-time engineering and science data flow from spacecraft to MOC to MDC immediately**
  - **Playback science and engineering data are stored at the Ground Station Front End, then retrieved by the MOC after contact**
  - **Spacecraft bus engineering data (and instrument status) are processed by the MOT at the MOC**
  - **MOC is responsible for DELIVERING instrument commands to spacecraft, NOT responsible for instrument command CONTENT**





# ***TIMED***

*Thermosphere • Ionosphere • Mesosphere • Energetics and Dynamics  
Flight Operations Review*



---

## **TIMED Mission Operations Concept (cont'd)**

- **Instrument Teams are responsible for operating instruments from flight Payload Operations Centers (POCs)**
  - **Instrument engineering and science data are processed at the individual POCs**
- **Each POC prepares command uploads and forwards them via FTP to MOC for transmission to the spacecraft**
  - **Event-driven or time-tagged commands**
  - **MOC authenticates command upload file**
  - **MOC verifies it is correctly addressed**
- **Each instrument stores and executes its own commands, time-tags its own data, which is then stored on the SSR for later downlink**



# ***TIMED***

*Thermosphere • Ionosphere • Mesosphere • Energetics and Dynamics  
Flight Operations Review*

---



## **TIMED Mission Operations Concept (cont'd)**

- **Downlinked data is forwarded by the MOC to the SDC**
  - **Cleaned and merged data can then be requested by the POC**
  - **POCs assess instrument data**
  - **Next command upload is prepared as required**
  
- **Operations are single-shift, seven days/week**
  - **Seven Mission Ops Team members, including the Mission Ops Manager**



# TIMED

*Thermosphere • Ionosphere • Mesosphere • Energetics and Dynamics  
Flight Operations Review*

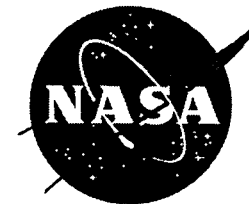

## TIMED Operations Concept (cont'd)

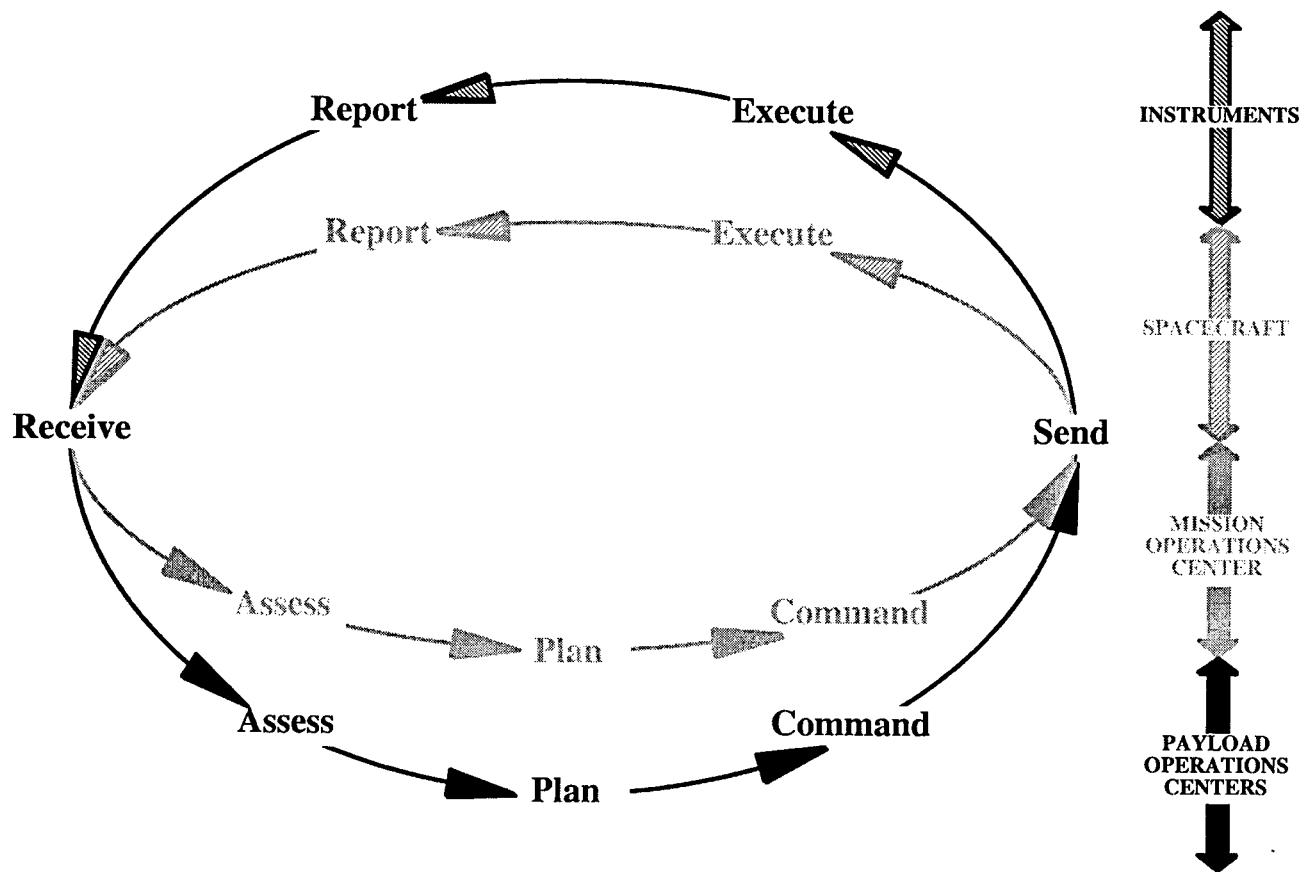



# **TIMED**

*Thermosphere • Ionosphere • Mesosphere • Energetics and Dynamics  
Flight Operations Review*

---

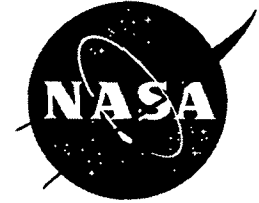

## **TIMED Mission Operations Concept (cont'd)**

- **MOC, Mission Data Center (MDC), Science Data Center (SDC), Ground Station, GUVI POC at APL**
  - **USN is back-up ground station(s)**
- **TIDI POC at SPRL Ann Arbor, MI**
- **SEE POC at LASP, Boulder, CO**
- **SABER POC at NASA Langley**
- **POCs connect to MOC via Internet or modem**
  - **Back-up POCs at APL**



# ***TIMED***

*Thermosphere • Ionosphere • Mesosphere • Energetics and Dynamics  
Flight Operations Review*

---



## **TIMED Mission Operations Concept (cont'd)**

- **“Event based” commanding replaces time-tagged command loads for repetitive events**
  - **GPS Navigation System (GNS) provides on-board knowledge of position, velocity and time**
    - **On-board notification provided to instruments of events of interest:**
      - **Terminator crossings**
      - **Polar region**
      - **SAA**
  - **Downlinks autonomously initiated in the course of normal operations**



# TIMED

*Thermosphere • Ionosphere • Mesosphere • Energetics and Dynamics  
Flight Operations Review*



## RFA Status from June 8, 2000 Review

TIMED Flight Operations Review Action Items				
AI #	Description	Assignee	Due Date	Status
1	Assessment Plan, Config control	Knopf	6/30/2000 for assessment plan, 9/1/00 for config control	Assessment plan closed. Config control closed per SEI-00-049, Sep 15 '00
2	Delta Review	Knopf	Launch - 5 months (October 7)	Closed, SEI-00-050, Sept 15, '00
3	Launch critical facilities and functions	Knopf	Launch - 4 months (November 7)	Closed, SEI-00-051, Sept 15, '00
4	Back-up to MOC/POCs	Rodberg	Delta Review	Open
5	MOM, Phase E Staffing	Grant	7/31/00	Closed
6	Ground test commands in flight database	Dragonette	7/31/00	Closed per SEI-00-047, Aug 31, '00
7	USN/TDRSS coordination	Knopf	Delta Review	Open
8	Realistic schedule and staffing plan	Knopf	Delta Review	Closed, SEI-00-052, Sept 15, '00
9	Automated tool for trending	Ossing/Campbell	6/30/00	Closed per PTS-00-009, Sept 20, '00
10	Auto-promote capability	Harvey	7/31/00	Closed; SEI-00-044, 04 Aug 2000
11	MOC firewall safeguards	Knopf	7/31/00	Closed, SEI-00-056, Sept 18, '00
12	GNS backup	Kusnierklewicz	7/31/00	NORAD response pending; I was working directly with someone at Cheyenne Mountain on this. Then I was referred back to fill out a form formally requesting the information from NORAD. I filled out the form and submitted it through Carl Smith at GSFC.
13	Assessment on orbit-by orbit basis	Ossing	Delta Review	Closed per PTS-00-009, Sept 20, '00
14	2-person review of commands	Knopf	Delta Review	Closed, SEI-00-053, Sept 15, '00



# TIMED

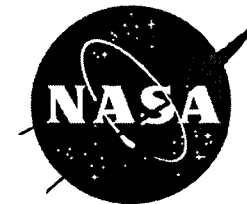

*Thermosphere • Ionosphere • Mesosphere • Energetics and Dynamics  
Flight Operations Review*

## Total Operating Hours (Pre- and Post- S/C Integration)

	<u>Pre Env</u> <u>10/17/99</u>	<u>Post Env</u> <u>2/15/2000</u>	<u>Post-Can</u> <u>9/22/2000</u>		<u>Pre Env</u> <u>10/17/99</u>	<u>Post Env</u> <u>2/15/2000</u>	<u>Post-Can</u> <u>9/22/2000</u>
• IEM#1 Receiver	1325 Hrs	2566 Hrs	4229 Hrs	• IEM#2 Receiver	1418 Hrs	2673 Hrs	4046 Hrs
• IEM#1 C&DH,SSR,GNS	937 Hrs	1947 Hrs	3180 Hrs	• IEM#2 C&DH,SSR,GNS	886 Hrs	1703 Hrs	2445 Hrs
• Xmtr#1	266 Hrs	528 Hrs	913 Hrs	• Xmtr#2	474 Hrs	656 Hrs	711 Hrs
• Riu's for IEM#1	978 Hrs	1961 Hrs	2866 Hrs	• Riu's for IEM#2	623 Hrs	1384 Hrs	1865 Hrs
• PSE Interface #1	734 Hrs	1976 Hrs	2987 Hrs	• PSE Interface #2	746 Hrs	1877 Hrs	3173 Hrs
• Battery On-Line	100 Hrs	1110 Hrs	1572 Hrs*				
• AIU#1	1013 Hrs	2129 Hrs	3230 Hrs	• AIU#2	752 Hrs	1552 Hrs	2285 Hrs
• Flight Computer#1	232 Hrs	815 Hrs	1498 Hrs	• Flight Computer#2	108 Hrs	464 Hrs	585 Hrs
• IRU (Gyro) #1	449 Hrs	778 Hrs	1504 Hrs	• IRU (Gyro) #2	181 Hrs	331 Hrs	910 Hrs
• Magnetometer #1	336 Hrs	695 Hrs	1522 Hrs	• Magnetometer #2	338 Hrs	669 Hrs	1492 Hrs
• Primary Torque Rods	68 Hrs	110 Hrs	477 Hrs	• Secondary Torque Rods	36 Hrs	52 Hrs	423 Hrs
• SAD #1	77 Hrs	89 Hrs	499 Hrs	• SAD #2	67 Hrs	76 Hrs	436 Hrs
• Star Tracker #1	7 Hrs	772 Hrs	1534 Hrs	• Star Tracker #2	8 Hrs	771 Hrs	1531 Hrs
• Reaction Wheel #1	662 Hrs	1290 Hrs	2100 Hrs	• Reaction Wheel #3	556 Hrs	1194 Hrs	1904 Hrs
• Reaction Wheel #2	663 Hrs	1301 Hrs	2109 Hrs	• Reaction Wheel #4	547 Hrs	1184 Hrs	1995 Hrs
• GUVI Instrument	1186 Hrs	1702 Hrs	2101 Hrs	• SEE Instrument	110 Hrs	701 Hrs	1175 Hrs
• SABER Instrument	739 Hrs	1433 Hrs	1902 Hrs	• TIDI Instrument	108 Hrs	787 Hrs	1239 Hrs

Flight Battery removed 2/11/2000 and stored, battery simulator used and number reflects Peak Power trackers usage.

PSE/DU has 843 hours since rework to correct single point failure

SEE has 296 hours since EGS rework

GUVI has 231 hours since 1553/tube rework

TIDI has 260 hours since Interpoint Converter rework/Cal lamp intensity variation tests



# **TIMED**

*Thermosphere • Ionosphere • Mesosphere • Energetics and Dynamics  
Flight Operations Review*

---



## **Schedule Overview**

- **FOPS Review** Nov 8-9, 2000
- **Pre-Ship Review** Nov 28
- **Testing Complete** Nov 30
- **Ship spacecraft to VAFB** Dec 11
- **Set-up Initial Ops** Dec 18 -22
- **Mission Ops Testing/Sims** Jan 15 - 19, 2001
- **S/C Flight Build & GSE Relocation** Jan 22 - Feb 3
- **S/C Battery Reconditioning** Feb 4 - 6
- **Boeing DPAF Operations** Feb 7 - 18
- **Boeing S/C Canning/LSRR** Feb 19 - 20
- **Mate DPAF to Delta** Feb 21
- **S/C Pad Functional/Pyro Arming** Feb 22
- **Simulated Countdown** Feb 23





# **TIMED**

*Thermosphere • Ionosphere • Mesosphere • Energetics and Dynamics  
Flight Operations Review*

---



## **Schedule Overview**

- **S/C Pad Functional** Feb 24 - 25
- **Pre-Fairing Inspection/Close-out** Feb 27
- **Fairing Installation** Feb 28
- **Flight Readiness Review** March 1
- **Mission Management Rehearsal** March 4
- **S/C Final Ops (Inspection, Batt Boost)** March 6
  - **Secure Fairing Access Door**
- **Power Up S/C in Launch Mode** March 7, T-10 hours
- **Launch** March 7

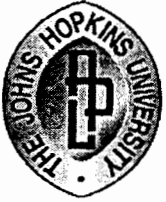

***TIMED***

*Thermosphere Ionosphere Mesosphere Energetics Dynamics  
Flight Operations Review*

---



# Spacecraft Modes

Mike Packard

Phone: 240-228-3516

e-mail: [michael.packard@jhuapl.edu](mailto:michael.packard@jhuapl.edu)

The Johns Hopkins University  
Applied Physics Laboratory  
Laurel, Maryland 20723

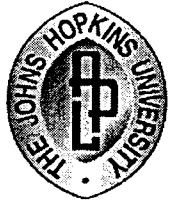

# TIMED

*Thermosphere Ionosphere Mesosphere Energetics Dynamics  
Flight Operations Review*

---



## Sub-system Mode Overview

- All modes are independent across sub-systems
  - One exception, in Safe Attitude, the Omni antenna will be turned on forcing the use of 10k bps TLM
- CDH
  - Boot
  - Application
    - TLM: 10k bps, 4M/2M bps, (5k bps)

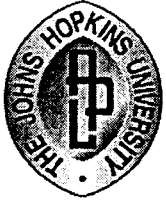

# TIMED

*Thermosphere Ionosphere Mesosphere Energetics Dynamics  
Flight Operations Review*

---



## Sub-system Mode Overview

- " GNS
  - Boot
  - Application
    - " Separation
    - " Non GPS Nav
    - " GPS Nav

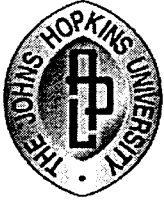

# TIMED

*Thermosphere Ionosphere Mesosphere Energetics Dynamics  
Flight Operations Review*

---

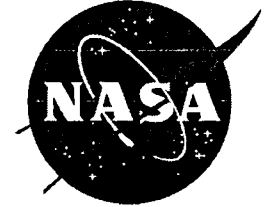

## Sub-system Mode Overview

- " G&C
  - Boot
    - " AFC
    - " AIU
  - Application
    - " Safe
    - " Nadir
    - " Operational

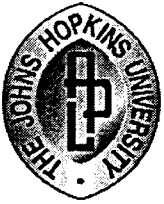

# TIMED

*Thermosphere Ionosphere Mesosphere Energetics Dynamics  
Flight Operations Review*

---



## C&DH/TLM Modes

- 10k bps - Used for omni coverage. Allows for 1 frame / second. Frame content is partially selectable
  - 5k bps - Special version of 10k. Used for EOPS with the link with TDRSS
- 4M/2M bps - Nadir pointing only. Normal operational mode, allows for SSR playback. Nominal rate is 4Mb, with 2Mb for higher link margins at some USN sites

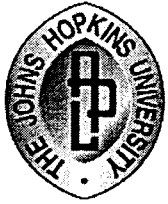

# TIMED

*Thermosphere Ionosphere Mesosphere Energetics Dynamics  
Flight Operations Review*

---



## GNS Modes

- Separation - Used once for EOPS, put into pre-launch vector. Waits for Separation signal from C&DH to propagate
- GPS Nav - Normal operation mode. Tracks satellites, goes to "fly-wheel" if have to propagate. Mode entered upon reboot.
- GPS Non Nav - Only propagates a loaded or last best solution. Does not use raw tracking data

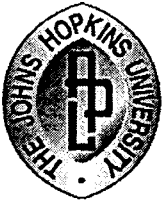

# TIMED

*Thermosphere Ionosphere Mesosphere Energetics Dynamics  
Flight Operations Review*

---



## G&C Modes

- Safe - designed to maximize the solar array pointing to the sun. Puts a body vector (nominally -Y) to the sun and solar arrays to the sun
  - Separation will be -Z axis to the sun with a 35° rotation in the -Y direction
- Nadir - Same control algorithms for operational mode. Nadir allows for slew times and requires fewer attitude determination sensors





# *TIMED*

*Thermosphere Ionosphere Mesosphere Energetics Dynamics  
Flight Operations Review*

---



## G&C Modes (con't)

- Operational - Normal mode. Fine attitude control and knowledge for science collection



# *TIMED*

## *Thermosphere Ionosphere Mesosphere Energetics Dynamics Flight Operations Review*

---



# Transitions

- C&DH/TLM and GNS are commanded transitions
- G&C can have auto or commanded demotion and commanded promotion
  - Demotion will occur due to a contingency or planned events
  - Promotion will occur due to a contingency recovery or planned event
    - Authority to promote will be from the Mission Operations Manager in the event of a contingency recovery



# TIMED

## Thermosphere Ionosphere Mesosphere Energetics Dynamics Flight Operations Review

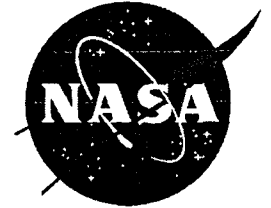

# G&C Allowable Transitions

**Demotion to Safe**  
soft LVSS discrete  
hard LVSS discrete  
sun keep-out zone violated  
Nadir pointing mode timeout  
timeout momentum out of range  
timeout on yaw maneuver  
yaw maneuver in progress and AFC loss

**Demotion to Nadir**  
timeout on missing GNS data  
timeout for one bad AST  
timeout for two bad AST  
timeout for missing IRU data  
attitude estimation problems  
timeout on attitude angle errors and or  
rate errors above threshold

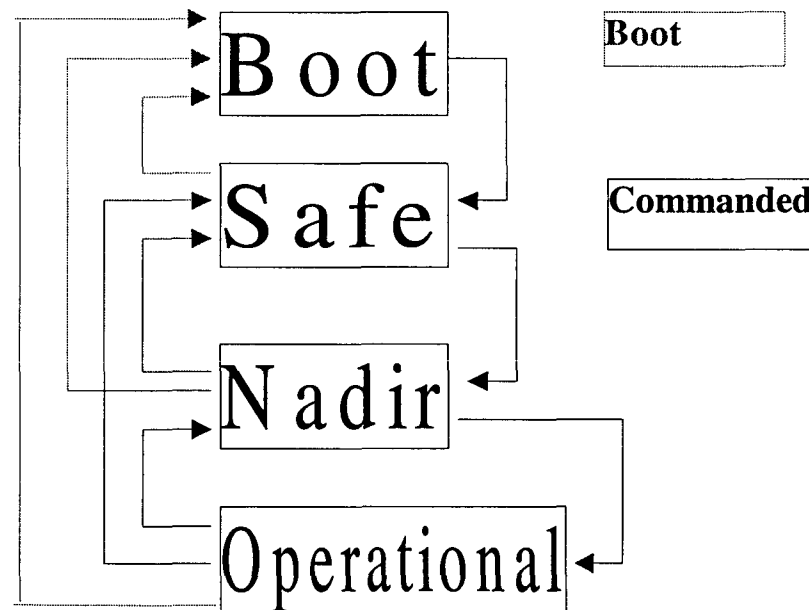



# ***TIMED***

*Thermosphere • Ionosphere • Mesosphere • Energetics and Dynamics  
Flight Operations Review*

---



## Operational Constraints

Paul Boie  
JHU/APL  
443-778-8385  
Paul.Boie@jhuapl.edu



# TIMED

*Thermosphere • Ionosphere • Mesosphere • Energetics and Dynamics  
Flight Operations Review*

---



## Operational Constraints

- Operational Constraints
  - Constraints defined by physical limitations of the spacecraft and instruments, or constraints defined by operation guidelines
  - Many constraints autonomously handled by autonomy or flight software
    - Example:
      - instrument survival heaters must be on if the instrument is off
        - » Autonomy ensures the survival heaters are on if the instrument is off
  - Constraints handled through operations procedures
    - Examples:
      - critical command decoder relay commands must be separated by 70 msec.
      - The TIDI instrument is allowed to record 103,878 packets to the solid state recorder each day



# TIMED

*Thermosphere • Ionosphere • Mesosphere • Energetics and Dynamics  
Flight Operations Review*

---



## Operational Constraints (cont.)

- Constraints handled through operations procedures are documented in Section 2 of the TIMED Operations Handbook
- Enforcement of procedural constraints
  - Examples:
    - STOL procedure and macro definition
      - ensuring a delay of proper length exists between commands that require a delay
      - verifying spacecraft configuration prior to sending commands
    - Front End Processor configuration
      - the Front End Processor places a 70 msec. delay between critical commands
    - Operations procedures
      - the limit on the number of packets an instrument may write to the solid state recorder



# TIMED

*Thermosphere • Ionosphere • Mesosphere • Energetics and Dynamics  
Flight Operations Review*

---



## Operational Constraints (cont.)

- Identified Procedural Constraints:
  - C&DH
    - Twenty seconds must separate all commands to program the C&DH flash memory.
    - Twelve seconds must be allowed between each flash erase command.
    - Flash memory must be erased prior to programming at all times. Failure to do so will result in double-bit errors which will not allow the jump from boot to application.
    - A C&DH dump should not be commanded while a dump is already in progress. This will result in a command execute failure.
  - Comm
    - The RF switches should not be commanded to a new position while their corresponding transmitter is powered on (no "hot" switching).



# TIMED

*Thermosphere • Ionosphere • Mesosphere • Energetics and Dynamics  
Flight Operations Review*

---



## Operational Constraints (cont.)

- Identified Procedural Constraints (cont.):
  - GNS
    - The GPS almanac should not be written to flash memory if the GNS parameters are not in a normal state. Most of the parameters are written to flash together.
    - A GNS dump should not be commanded while a dump is already in progress. This will result in a GNS command reject.
  - Mongoose Processors (C&DH, GNS, G&C)
    - The mongoose processors should not be reset while flash is being written to. This will cause the processor to enter an inoperable state which can only be corrected with a power cycle.
  - PSE/DU
    - CCD relay commands must be separated by 70 msec.





# TIMED

*Thermosphere • Ionosphere • Mesosphere • Energetics and Dynamics  
Flight Operations Review*

---



## Operational Constraints (cont.)

- Identified Procedural Constraints (cont.):
  - All Instruments (GUVI, SABER, SEE, TIDI)
    - The instruments must be given a 10 second warning prior to powering them down for an emergency such as an LVS condition.
  - GUVI
    - GUVI is limited to recording 337,560 packets each GMT day.
  - SABER
    - SABER is limited to recording 165,341 packets each GMT day.
  - SEE
    - SEE is limited to recording 9497 packets each GMT day.
  - TIDI
    - TIDI is limited to recording 104,877 packets each GMT day.



# ***TIMED***

*Thermosphere • Ionosphere • Mesosphere • Energetics and Dynamics  
Flight Operations Review*

---



## On-Board Memory Management

Paul Boie  
JHU/APL  
443-778-8385  
Paul.Boie@jhuapl.edu



# TIMED

*Thermosphere • Ionosphere • Mesosphere • Energetics and Dynamics  
Flight Operations Review*

---



## On-Board Memory Management

- Types of Memory Managed
  - EEPROM and Flash Memory - Non-volatile memory
    - EEPROM - AIU; enough memory for one application program
    - Flash Memory - Mongoose processors; sufficient memory for multiple copies of application programs as well as structures or constants (parameters)
  - RAM - Volatile memory
- What is managed
  - Application programs
    - managed using procl program
  - Structures or constants
    - managed using Parameter Archive Module (PAM) for G&C and GNS, and Memory Allocation Examiner (MAX) for C&DH
      - MAX used to manage Flash and RAM memory
      - PAM used to manage RAM memory



# TIMED

*Thermosphere • Ionosphere • Mesosphere • Energetics and Dynamics  
Flight Operations Review*

---



## On-Board Memory Management

- Parameter Archive Module (PAM)
  - Application run on Windows NT
  - tracks the current state of Guidance and Control (G&C) and GPS Navigation System (GNS) constants (i.e., data structures, configuration tables, etc.) using a Microsoft Access database
  - PAM reflects what is on-board the spacecraft
  - Uses engineering dump data provided to PAM post-pass via Pass Manager software
    - the engineering dump application extracts parameter data from dump data stored in the Mission Data Center



# TIMED

*Thermosphere • Ionosphere • Mesosphere • Energetics and Dynamics  
Flight Operations Review*

---



## On-Board Memory Management (cont.)

- Memory Allocation Examiner (MAX)
  - Visual C++ application run on a PC using Windows NT
  - Autonomy, Macros, Time-tagged commands
    - tracks the current state of autonomy rules, macros, time-tagged commands and their flash memory status
    - detects changes by monitoring uplink activity (via command event logs) and by examining structure dump files
    - reports inconsistencies between what is stored in MAX and what is received from the spacecraft dump
    - tracks interactions
      - example: whether a time-tagged command is loaded from a macro and which macro



# TIMED

*Thermosphere • Ionosphere • Mesosphere • Energetics and Dynamics  
Flight Operations Review*

---



## On-Board Memory Management (cont.)

- Autonomy, Macros, Time-tagged commands (cont.)
  - MAX used for planning purposes; prior to any additions, changes, or deletions, MAX will be used to determine the effects of the addition, change, or deletion
- provides a daily, chronological log of all commands, telecommand packets, and command failure histories from the C&DH processor



# ***TIMED***

*Thermosphere • Ionosphere • Mesosphere • Energetics and Dynamics  
Flight Operations Review*

---



## **Flight Software Status and Maintenance**

Martha I. Chu

Phone: (240) 228-7961

Fax: (240) 228-3839

e-mail: [martha.chu@jhuapl.edu](mailto:martha.chu@jhuapl.edu)

The Johns Hopkins University  
Applied Physics Laboratory  
Laurel, Maryland 20723



# ***TIMED***

*Thermosphere • Ionosphere • Mesosphere • Energetics and Dynamics  
Flight Operations Review*

---



## **Flight Software Status**

<b>Flight Software</b>	<b>First Delivery Date</b>	<b>Last Delivery Date</b>
<b>AIU Boot Code (in PROM)</b>	<b>11/98</b>	<b>11/98</b>
<b>Mongoose Boot Code</b>	<b>10/98</b>	<b>9/99</b>
<b>Command and Data Handling</b>	<b>10/98</b>	<b>10/00</b>
<b>GPS Navigation System</b>	<b>9/98</b>	<b>10/00</b>
<b>Guidance and Control</b>	<b>4/99</b>	<b>2/00</b>
<b>Autonomy Rules</b>	<b>1/00</b>	<b>10/00</b>





# TIMED

*Thermosphere • Ionosphere • Mesosphere • Energetics and Dynamics*

*Flight Operations Review*



## Current Flight Software Problems (10/30/00)

Function	Problem_Description	State
AFC	The accuracy of attitude control and the accuracy of knowledge control have not been tested.	Submitted
Boot Code	The common boot does not accept the "desired" start addresses for application programs. The addresses accepted by the common boot allow it to start the application program but in DRAM space which is slower than the desired SRAM space.	Submitted
Boot Code	The Common Boot 0.7 normal telemetry does not indicate the RAM test address range specified in the Boot Block Cell.	Submitted
GNS	There is a conflict between some GNS boot command opcodes and some GNS application software opcodes. In order to prevent potential problems, the GNS application code should be changed to accept both the old opcodes (for backward compatibility) and a new set of opcodes (which do not conflict with the boot opcodes).	released
GNS	When structure 40 (the almanac) on the GNS is dumped it appears that it is about one packet short of a complete dump. There are 2016 of 2260 bytes dumped.	Submitted
GNS	The command GN_LOG_MEM_DMP proc=np id=22 which dumps logical memory segment 22 caused the GNS to reset during the 96 hour test.	fixed



# TIMED

Thermosphere • Ionosphere • Mesosphere • Energetics and Dynamics  
Flight Operations Review



## Software Problem Report Process

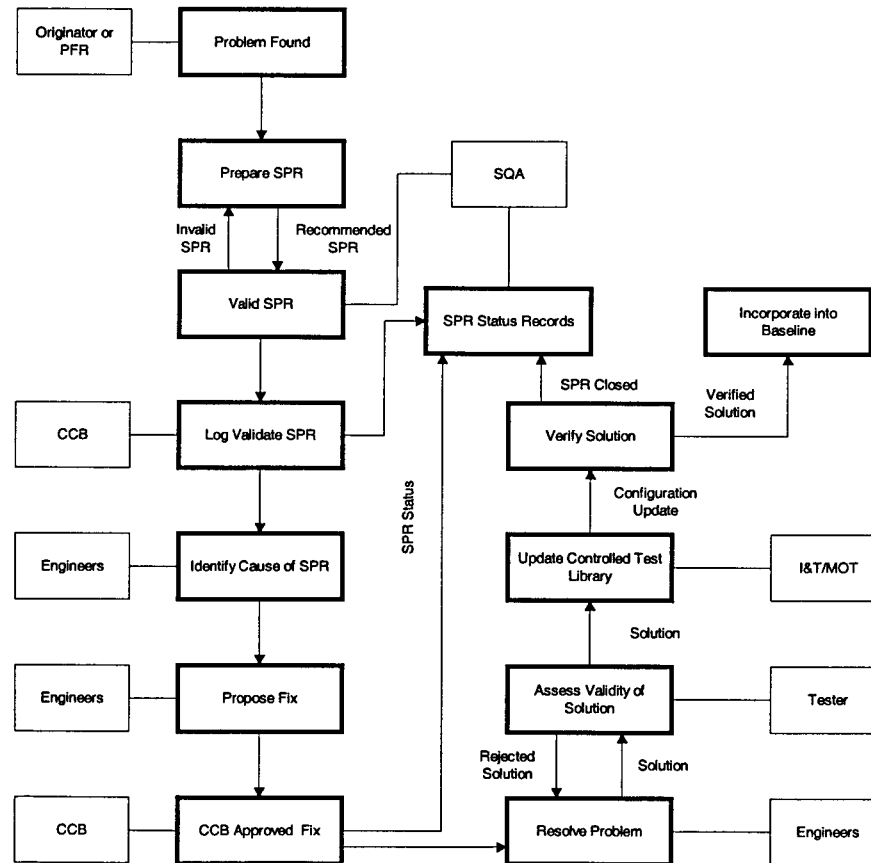

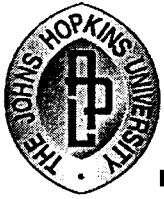

# **TIMED**

*Thermosphere • Ionosphere • Mesosphere • Energetics and Dynamics  
Flight Operations Review*

---



## **Flight Software Maintenance**

- Follow the Software Problem Report process
  - Analyze the problem
  - Fix the problem
  - Test in the test bed
  - Run all regression tests
  - Deliver the update software to Mission Operations Team
  - Load the software on to the TIMED Operations Simulator (TOPS)
  - Test on the TOPS
  - Load to the redundant processor on the spacecraft
  - Test on the redundant processor
  - Load to the primary processor on the spacecraft
  - Test on the primary processor



# ***TIMED***

*Thermosphere • Ionosphere • Mesosphere • Energetics and Dynamics  
Flight Operations Review*

---



## ***Ground System Engineering***

Elliot Rodberg

Phone: 240-228-5318

e-mail: [elliott.rodberg@jhuapl.edu](mailto:elliott.rodberg@jhuapl.edu)

The Johns Hopkins University  
Applied Physics Laboratory  
Laurel, Maryland 20723



# TIMED

*Thermosphere • Ionosphere • Mesosphere • Energetics and Dynamics  
Flight Operations Review*



## TIMED Ground System Components

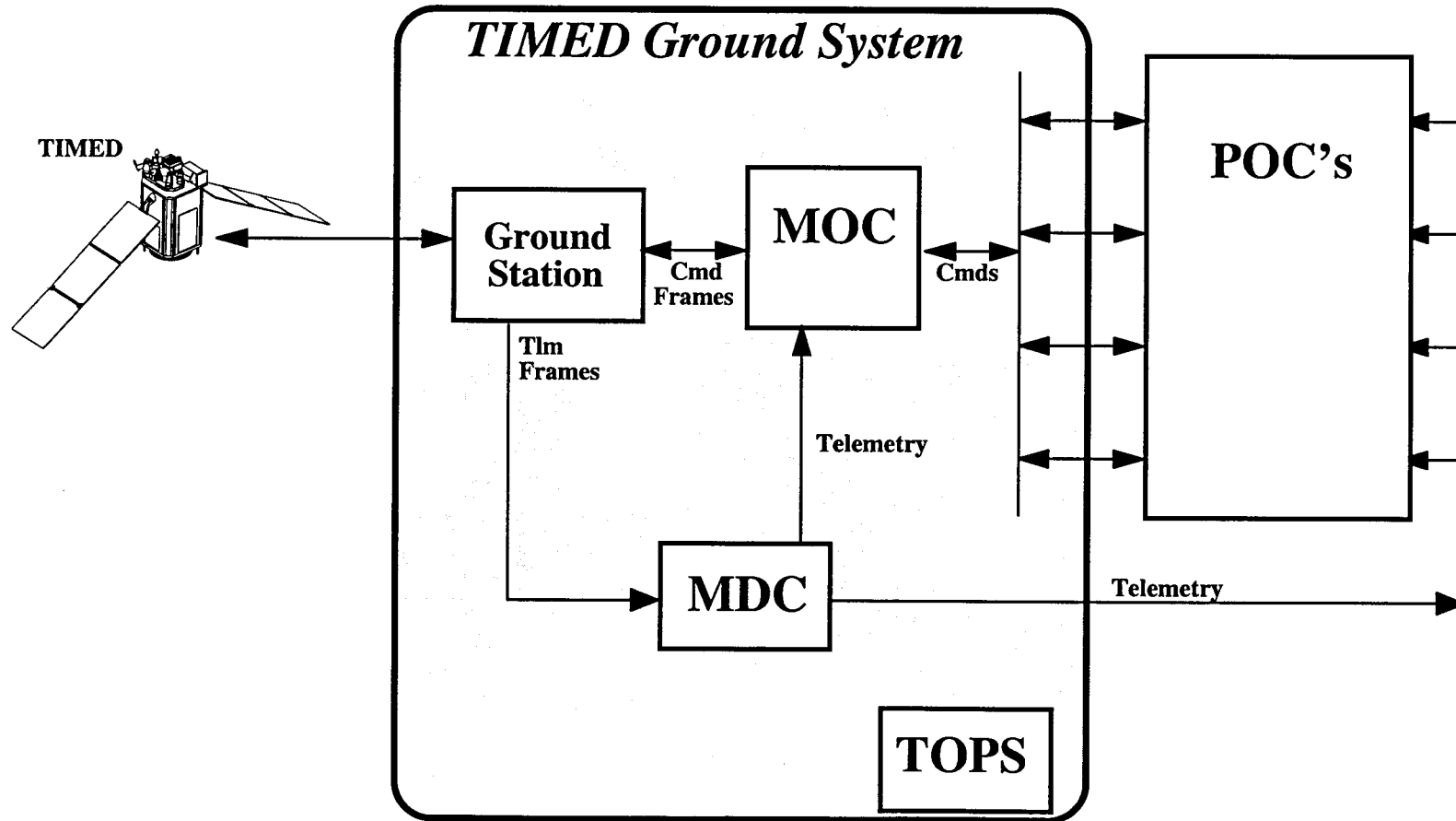



# TIMED

*Thermosphere • Ionosphere • Mesosphere • Energetics and Dynamics  
Flight Operations Review*



## Ground System Architecture

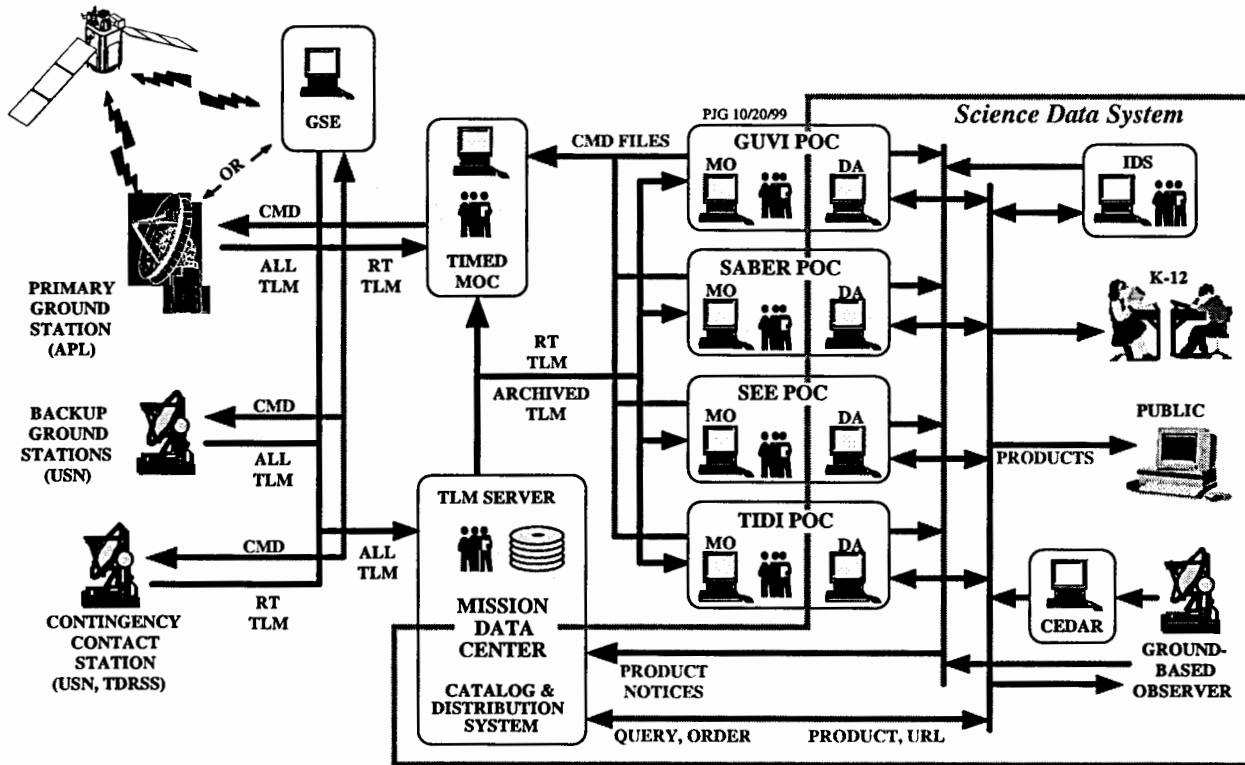



# TIMED

Thermosphere • Ionosphere • Mesosphere • Energetics and Dynamics  
Flight Operations Review



## TIMED Flight Ops Network

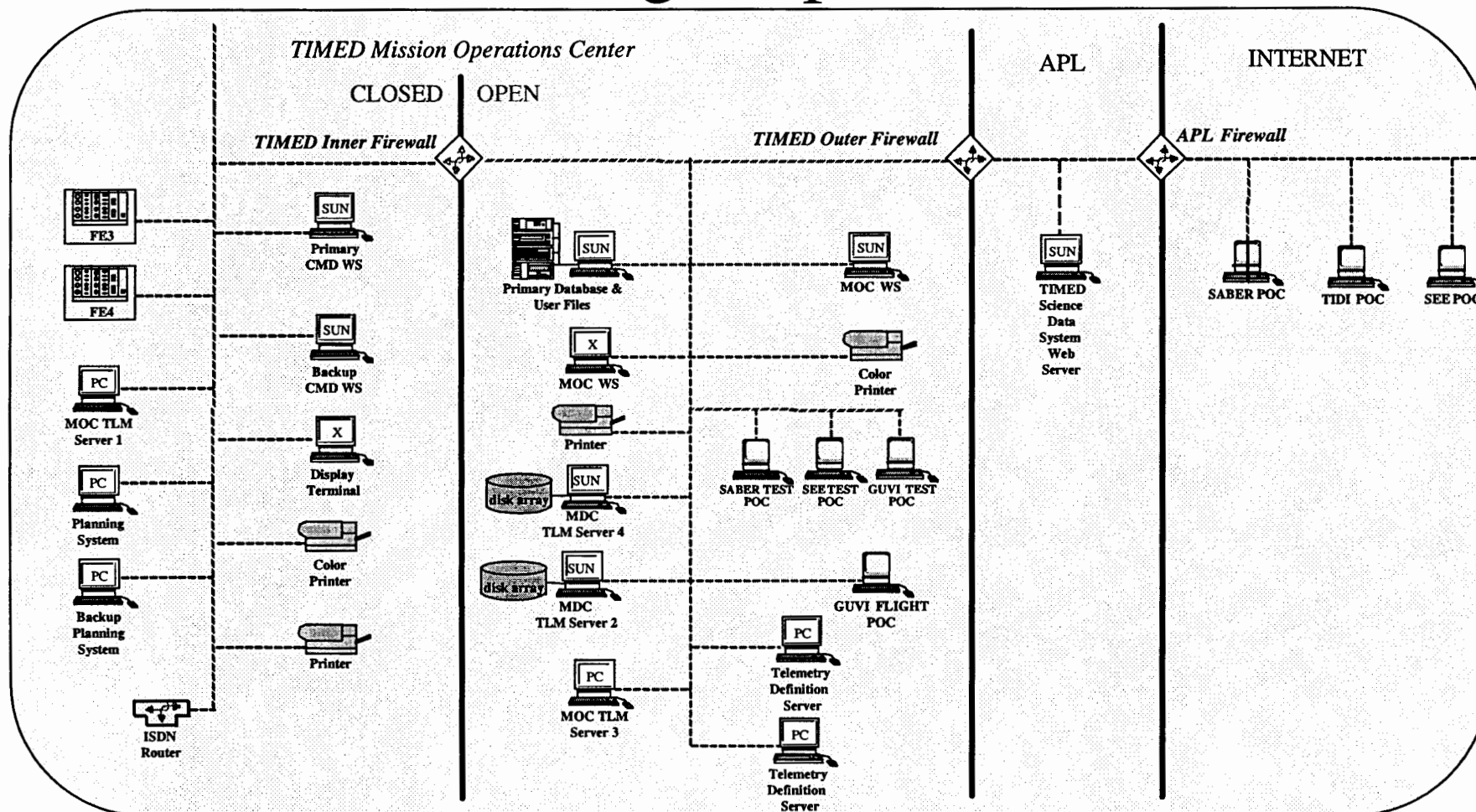



# TIMED

Thermosphere • Ionosphere • Mesosphere • Energetics and Dynamics

Flight Operations Review



## Flight Operations Network Configuration

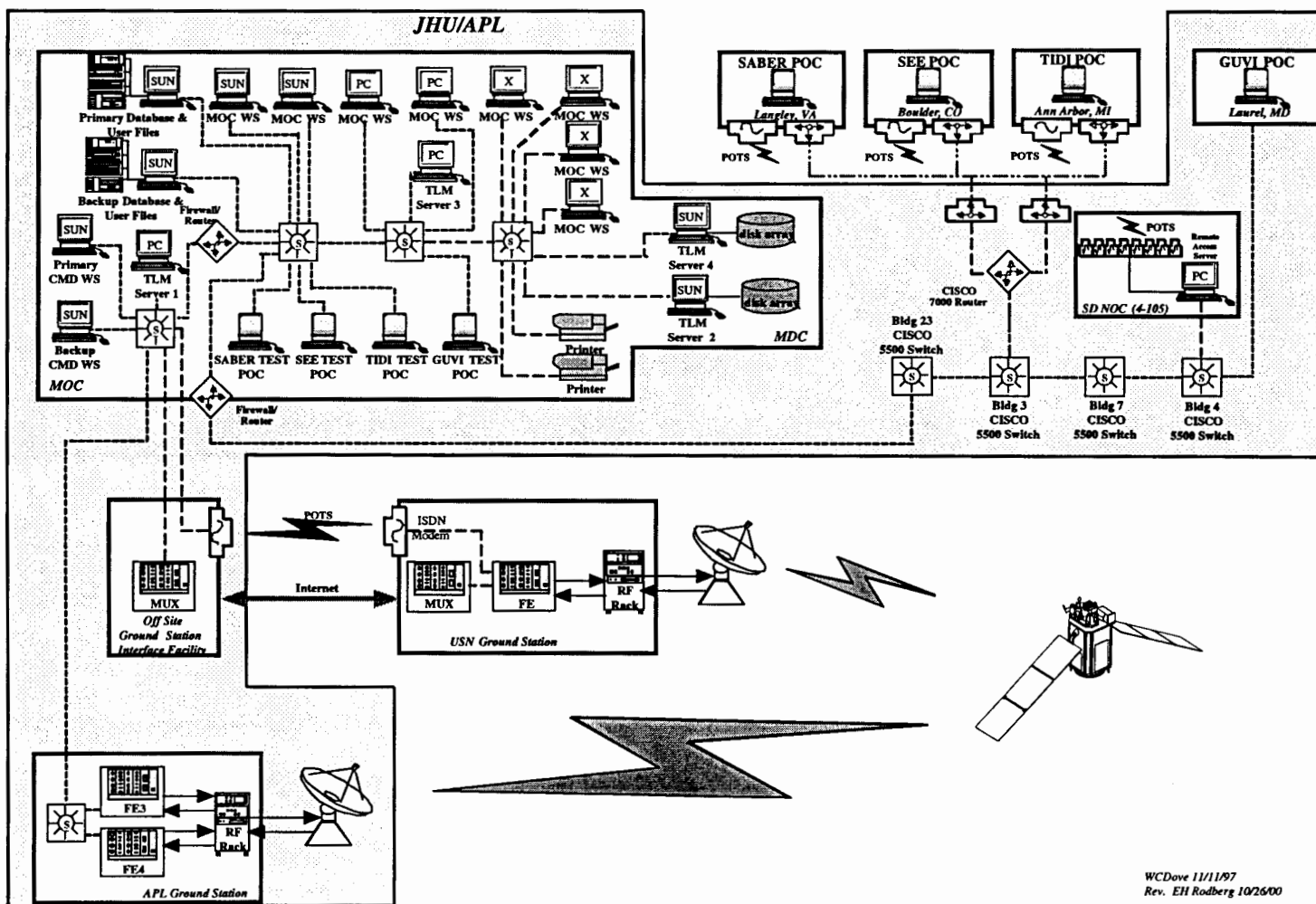

WCDove 11/11/97  
Rev. EH Rodberg 10/26/00





# TIMED

Thermosphere • Ionosphere • Mesosphere • Energetics and Dynamics  
Flight Operations Review



## Command Data Flow

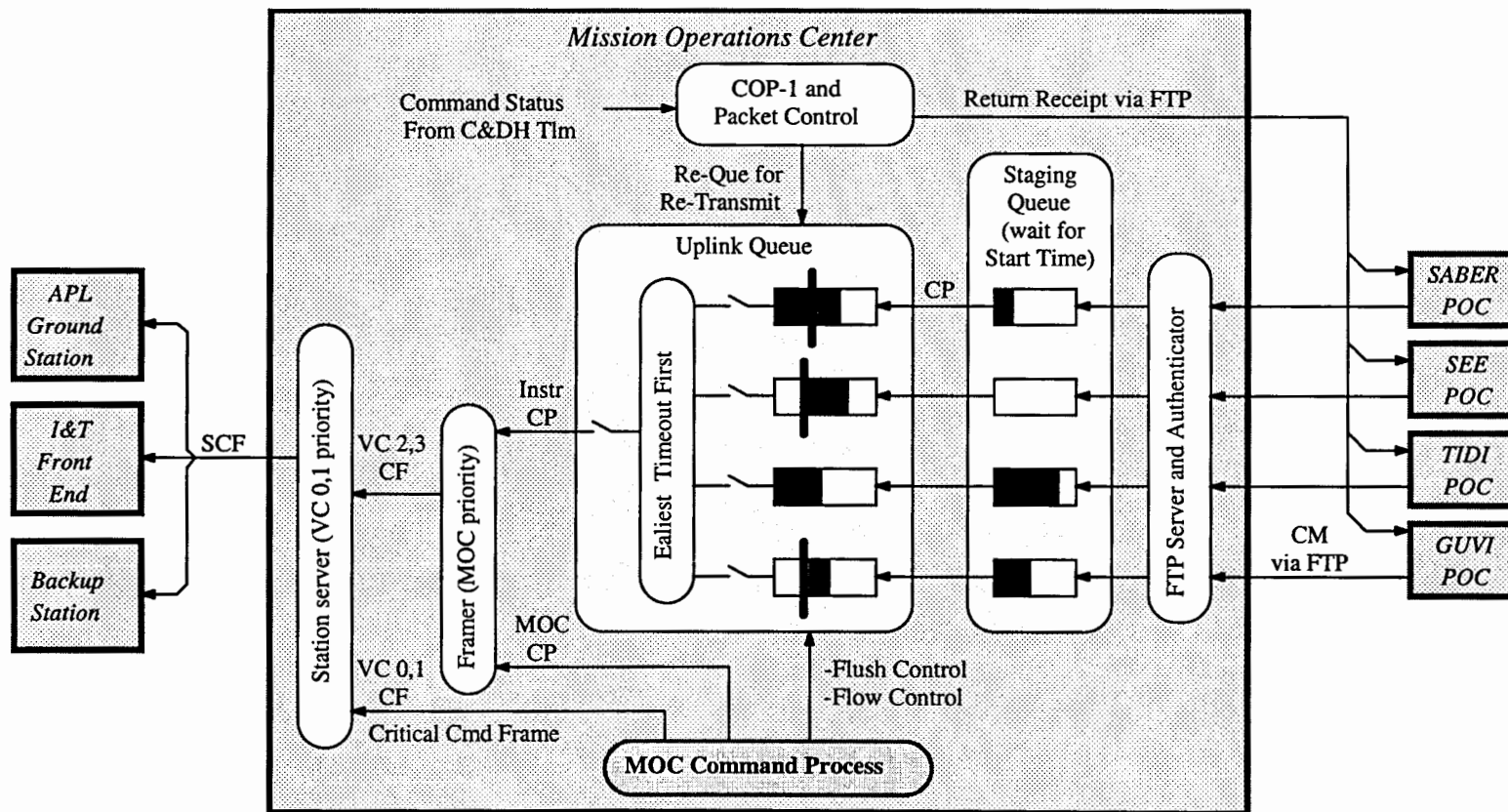

PIG, rev e, 11/12/97

### Command Message Types

- CM = [POC-MOC] Command Message
- CP = Command Packet
- SCF = Supplemented Cmd Frame
- CF = Command Frame



# TIMED

*Thermosphere • Ionosphere • Mesosphere • Energetics and Dynamics  
Flight Operations Review*

---



## POC Interfaces

- Network Connections
  - Primary Interface is the Internet
  - Backup Interface is modem into TIMED MOC
- Commanding
  - Secure FTP using PGP
  - Connect into TIMED MOC outer network
  - Drop off command files
  - Software moves file to command workstation in closed network
- Telemetry
  - Connect to MDC Telemetry Server
  - MDC Telemetry Server is in outer network



# TIMED

Thermosphere • Ionosphere • Mesosphere • Energetics and Dynamics  
Flight Operations Review

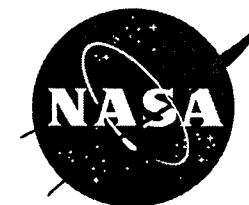

## TIMED Mission Data Flow

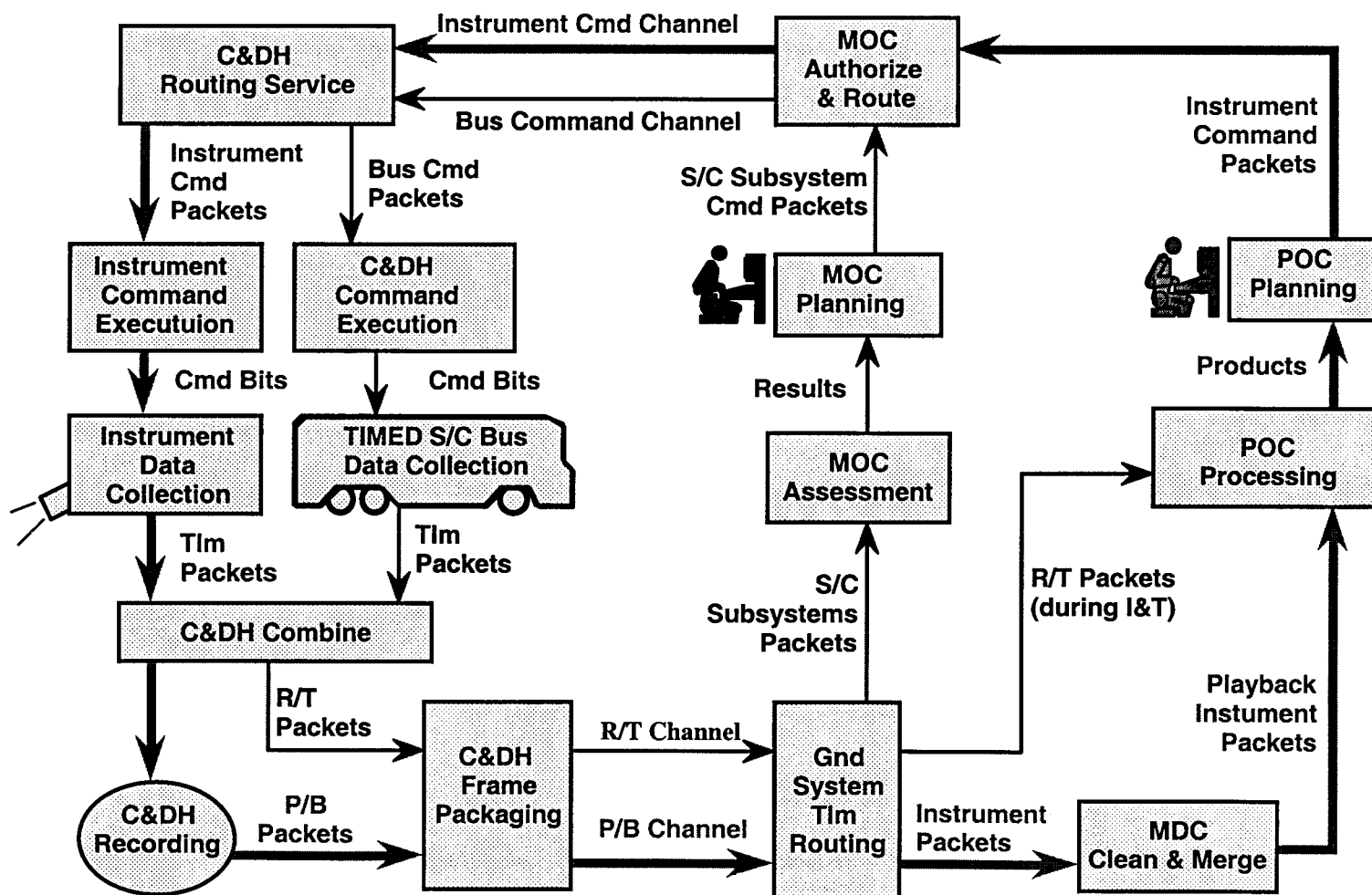

FIG, Rev f, 12/26/97



# TIMED

*Thermosphere • Ionosphere • Mesosphere • Energetics and Dynamics  
Flight Operations Review*

---



## MOC Design Highlights

- Built around COTS software (EPOCH 2000)
- Supports independent commanding by MOC and POCs
- Supports real time or store-and-forward commands from POCs
- Uses same system for
  - Subsystem Test (Mini-MOC)
  - Integration & Test
  - Mission Operations
- GSE commanding and status telemetry interfaces
- Memory management tools for spacecraft processors
- Derived Telemetry
- Engineering Dump
- Other Tools



# TIMED

*Thermosphere • Ionosphere • Mesosphere • Energetics and Dynamics  
Flight Operations Review*

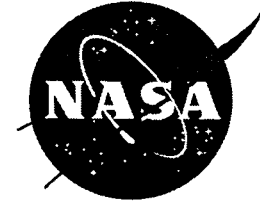

## Mission Operations Software

- MOC Real-Time Control
  - EPOCH 2000 (COTS)
  - Oracle (COTS)
  - CmdIf
  - TlmIF
  - MPCF
  - ProcD
  - BuildTlm
  - CmdGen
  - DerivedTlm
  - MAX
- Front End
  - EPOCH 2000 (COTS)
  - LEO-T (COTS)
- MDC Software
  - Telemetry Router
  - Telemetry Spooler
  - Telemetry Ingest
  - Archive Server
- Science Data System
  - Web Site
  - Orbit Processor
  - Archive Map Utility
  - Operations Reports
- MOC Planning and Assessment
  - Scheduler
  - Pass Manager
  - EngDump
  - Plot Manager
  - Plotter
  - ProcL, ProcC



# TIMED

*Thermosphere • Ionosphere • Mesosphere • Energetics and Dynamics*

*Flight Operations Review*



## Ground System Software

- All operational software delivered and under configuration control
- Real-time system used every day 9am - 5pm, more during sims
- Exercised all operational, planning, and assessment software, as well as Ground Station and Mission Data Center during Mission Simulations
  - 96 hour test in Jan 00
  - 96 hour test in March 00
  - 96 hour test in August 00
  - 96 hour test in October 00
  - Launch and Early Operations Simulations
    - 7/12/99
    - 8/11/99
    - 1/10/00
    - 1/16/00
    - 1/25/00
    - 8/18/00
    - 10/5/00
    - 10/18/00



# TIMED

*Thermosphere • Ionosphere • Mesosphere • Energetics and Dynamics  
Flight Operations Review*

---



## Mission Operations Center Software

- ProcL (Processor Load)
  - Rewrite nearly complete
  - Improved user interface and enhanced memory management
  - Mongoose Load successfully tested on TOPS
  - RTX2010 (AIU) Load nearing completion
  - Release due by December 1
- ProcD (Processor Dump)
  - Corrected problems with GNS structure dumps
  - Configuration file updated to handle G&C parameter dumps
  - Enhanced to distinguish RAM and Flash memory status
  - Fixing error handling to improve robustness
  - Recent update Released Nov 1



# ***TIMED***

*Thermosphere • Ionosphere • Mesosphere • Energetics and Dynamics  
Flight Operations Review*

---



## Mission Operations Center Software

- Memory Allocation Examiner (MAX)
  - Manages C&DH parameters (macros, autonomy rules, and timetags)
  - Used for spacecraft and simulator memory management
  - Planning function allows allocation of parameter space
  - Identifies differences between uploaded and dumped parameters
  - Maintains history of parameter loads in timeline mode
  - NEAR heritage





# **TIMED**

*Thermosphere • Ionosphere • Mesosphere • Energetics and Dynamics  
Flight Operations Review*

---



## **Ground System Software Delivery Status**

<b>Ground Software</b>	<b>First Delivery Date</b>	<b>Latest Delivery Date</b>
<b>Mission Operations Center</b>	<b>10/98</b>	<b>10/00</b>
<b>Mission Data Center</b>	<b>10/98</b>	<b>10/00</b>
<b>Front End</b>	<b>10/98</b>	<b>9/00</b>
<b>Ground Station</b>	<b>3/00</b>	<b>3/00</b>



# TIMED

*Thermosphere • Ionosphere • Mesosphere • Energetics and Dynamics  
Flight Operations Review*



## Ground System Software Delivery Status

<b>Ground Support Equipment</b>	<b>First Delivery Date</b>	<b>Latest Delivery Date</b>
<b>Blockhouse Control Unit</b>	<b>10/98</b>	<b>12/99</b>
<b>GPS Simulator</b>	<b>5/99</b>	<b>9/99</b>
<b>IEM Test bed</b>	<b>6/99</b>	<b>6/00</b>
<b>TIMED Attitude System Test and Integration Equipment (TASTIE)</b>	<b>6/99</b>	<b>9/00</b>
<b>RF GSE</b>	<b>3/99</b>	<b>3/99</b>



# TIMED

Thermosphere • Ionosphere • Mesosphere • Energetics and Dynamics  
Flight Operations Review



## TIMED SPRs by Subsystem\*

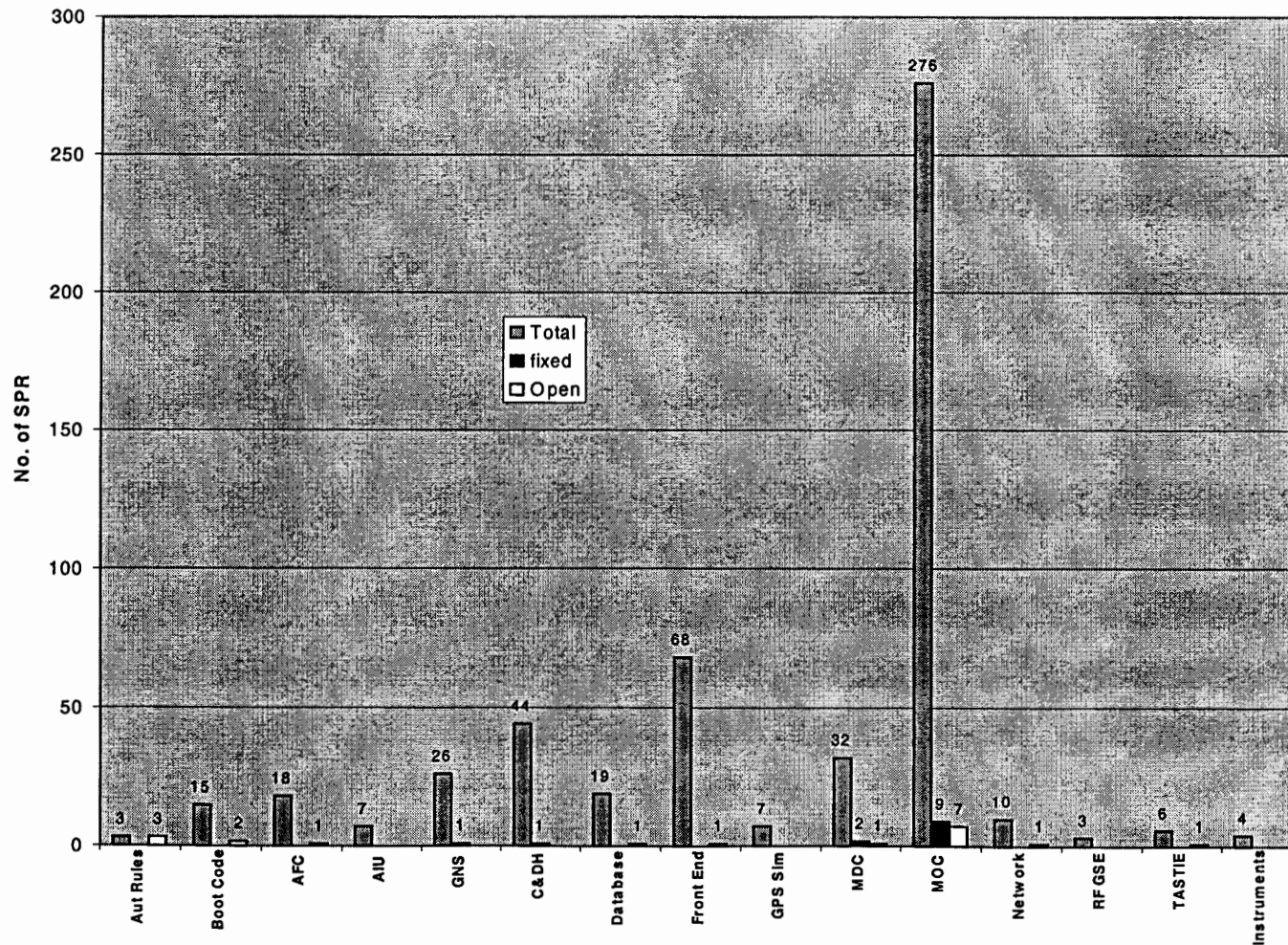

\*As of Oct 20, 2000



# TIMED

Thermosphere • Ionosphere • Mesosphere • Energetics and Dynamics  
Flight Operations Review



## TIMED Open SPRs by Subsystem\*

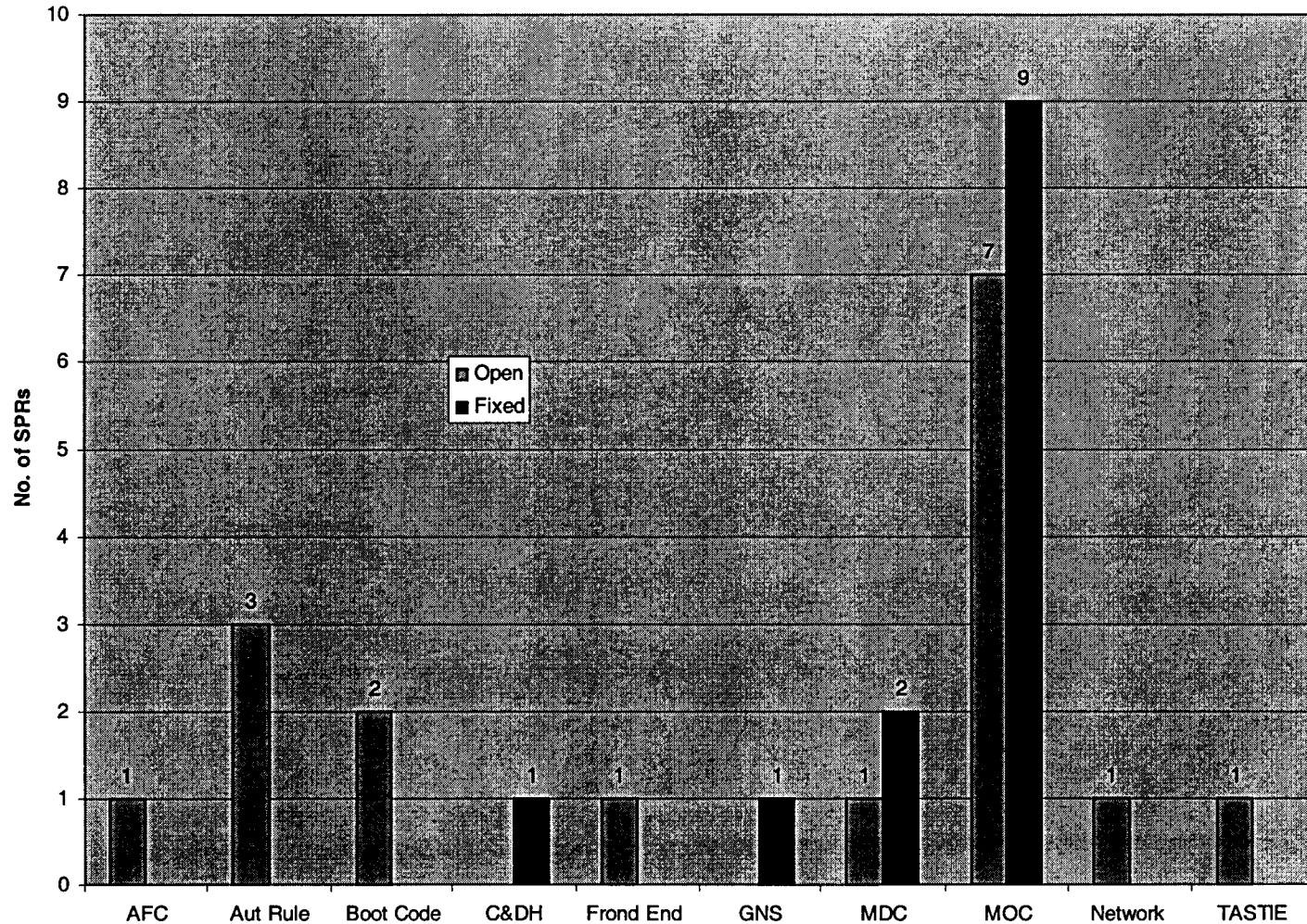

\*As of Oct 20, 2000



# TIMED

*Thermosphere • Ionosphere • Mesosphere • Energetics and Dynamics  
Flight Operations Review*

---



## Mission Operations Center SPRs

- Total Open SPRs - 22
  - 11 fixed or released
  - 2 on old ProcL, superseded by code rewrite
  - 2 on ProcD
    - 1 enhancement to ProcD - Separate RAM and Flash Images
    - 1 robustness handling error conditions, ProcD
  - 1 enhancement to CmdIF - GSE no-disconnect
  - 1 bug fix for commands in POC Queues with same enable time
  - 1 viewer crash, core file analyzed, problem found. fix underway.
  - 1 user account privileges
  - 1 enhancement to MAX to track timetag cmds called by macros
  - 1 enhancements to Assessment software per 96 hour test results
  - 1 low priority enhancement requests, Minor display problem



# *TIMED*

*Thermosphere • Ionosphere • Mesosphere • Energetics and Dynamics  
Flight Operations Review*

---



## Mission Data Center SPRs

- 3 Open SPRs
  - 2 released, will be verified and closed following next 96 hour test
  - 1 will be closed following installation of new telemetry server workstation
  - All relate to marginal MDC performance
  - Performance improvement expected with installation of new workstation
  - Plan is to configure and install new workstation by Nov 10.
  - Use 96-hour Mission Simulation the following week to verify improved performance, and close out the SPRs.



# TIMED

*Thermosphere • Ionosphere • Mesosphere • Energetics and Dynamics  
Flight Operations Review*

---



## Front End SPRs

- 1 Open
  - Avtec Telemetry Processor Card freezes when put into standby mode.
  - ISI and Avtec have both been here to analyze problem.
  - Avtec claims it is a Modcomp (COTS OS supplier) problem.
  - They have been contacted, with no results.
  - Problem has not occurred on operational system since February 2000.
- 1 Fixed
  - Ready to test (may have been closed by now)
  - Correct a time stamp on a log message



# TIMED

*Thermosphere • Ionosphere • Mesosphere • Energetics and Dynamics  
Flight Operations Review*

---



## Ground System SPRs - Other

- Network - 2 Open SPRs
  - 3 minute dropout from January
    - Localized source of problem, but not fixed yet, still working it
    - Concern for Launch Ops, not problem post-launch
  - 10 minute dropout during 96-hour test in Oct 00
    - Same symptoms as 3 minute dropout
    - Still investigating
- Other Systems - 3 Open SPRs
  - TASTIE enhancement for TOPS
  - Database enhancement to handle automatic removal of tlm points
  - GSE to MOC communications problem during long idle periods





# TIMED

*Thermosphere • Ionosphere • Mesosphere • Energetics and Dynamics  
Flight Operations Review*

---



## Ground Stations

- Primary Ground Station is at APL
  - Use existing 60-foot antenna system
    - Modified feed to add S-band transmit capability
  - Logistic advantages
    - Priority for TIMED support
    - Local interface to MOC and MDC
    - Accessible for integration, compatibility tests
- Backup Ground Station services provided by Universal Space Networks (Horsham, PA)
  - Expanded coverage during Early Operations
  - Available for contingency support
  - Planned contact once a week



# TIMED

Thermosphere • Ionosphere • Mesosphere • Energetics and Dynamics  
Flight Operations Review



## Primary Ground Station

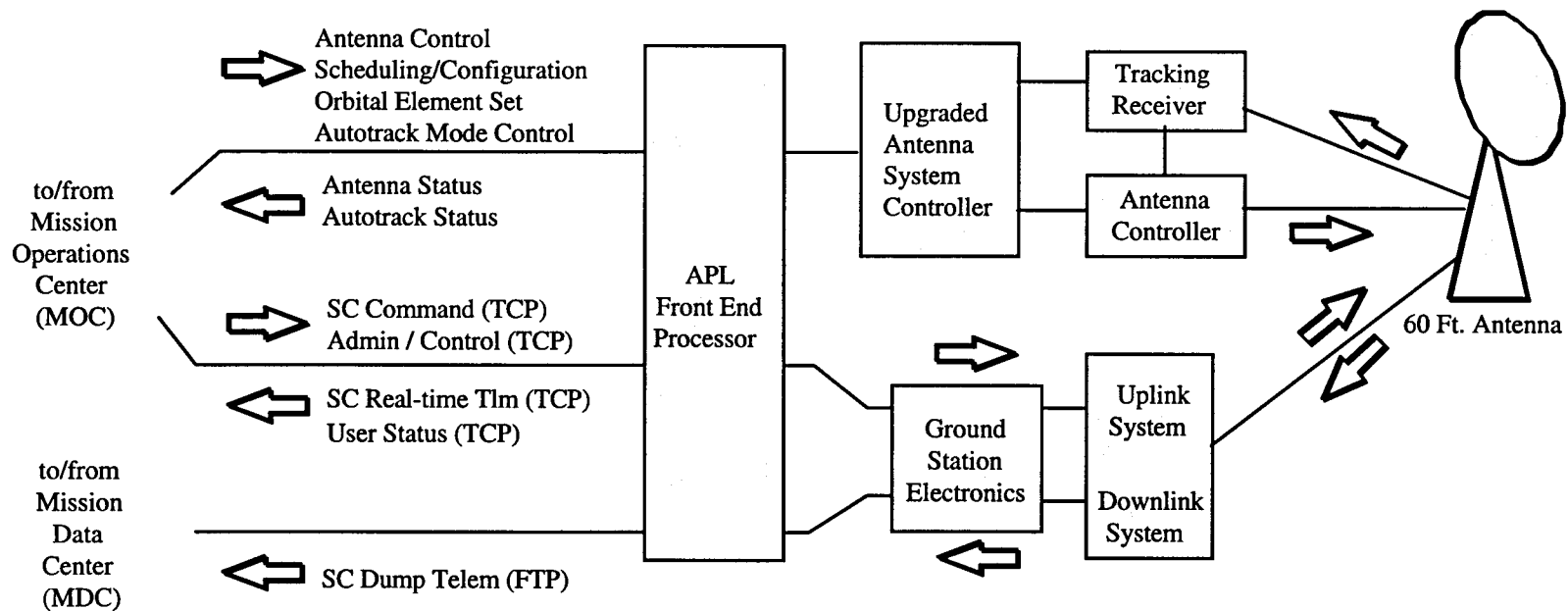

SEGemeny/PJGrunberger 11/12/97



# TIMED

*Thermosphere • Ionosphere • Mesosphere • Energetics and Dynamics  
Flight Operations Review*

---



## Ground Station Features

- Primary Ground Station- APL
  - Remotely scheduled from MOC
  - Automated scheduling/configuration
  - LEO-T compatible TCP/IP external interface
  - Extensively tested with live spacecraft
- Backup Ground Stations - USN
  - Remotely scheduled from MOC
  - Same look-and-feel as Primary Station to MOC/MDC
  - Two links to APL MOC/MDC:
    - ISDN
    - Internet socket connection



# TIMED

*Thermosphere • Ionosphere • Mesosphere • Energetics and Dynamics  
Flight Operations Review*

---



## Universal Space Networks - Test Summary

- July 1999 at APL (2 days)
  - RF Compatibility Testing
  - Tested using the spacecraft
  - Several Performance parameters out of spec, requiring retest
- December 1999 at USN, Horsham, PA (6 days)
  - RF Compatibility
  - Ground System Processing and Interfaces
  - Tested using the Engineering Model IEM



# TIMED

*Thermosphere • Ionosphere • Mesosphere • Energetics and Dynamics  
Flight Operations Review*

---



## Universal Space Networks - Test Summary

- Results of December 1999 Testing
  - *Successful commanding* of the spacecraft via RF from the APL MOC (although "long" commands were not tested)
  - *Successful real-time spacecraft telemetry flow* via RF to the APL MOC.
  - *Successful status-telemetry flow* from USN to the APL MOC (although some content issues remain).
  - *Successful ground capture of an SSR dump* at 4 Mb/s (although there were some problems with USN reports of non-existent gaps in the data.)



# ***TIMED***

*Thermosphere • Ionosphere • Mesosphere • Energetics and Dynamics  
Flight Operations Review*

---



## Universal Space Networks - Test Summary

- October 2000 at APL (2 days)
  - RF Compatibility
  - Tested using the spacecraft
  - Results now show acceptable RF performance
- Tests Planned
  - November 15, 2000 at APL (3 days)
    - End-to-End Compatibility Testing
    - Incorporate all ground system interfaces



# TIMED

*Thermosphere • Ionosphere • Mesosphere • Energetics and Dynamics  
Flight Operations Review*



## USN - Interface Documents

- Interface Control Documents
  - TIMED Backup Ground Station Network to Spacecraft
    - APL TIMED Document # 7363-9389
  - USN Ground Network to TIMED Mission Operations Center
    - USN Document Number 143, Revision D, July 6, 2000
    - Signoff pending updates by USN and November Testing
- USN test reports
  - USN RF Compatibility Test Report for the TIMED Satellite, USN Document # 158, Rev. D, September 1999
  - USN Supplemental RF Compatibility Test Report, TIMED, USN Document #167, rev. A, December 1999
- USN end-to-end test plan
  - USN End-to-End Compatibility Test Plan, USN Document # 152, Rev. B, October 1999
  - TIMED-USN End-to-End Compatibility Test Plan , APL Supplement, Grunberger/Rodberg/Dove, Version c, 10/18/99



# TIMED

*Thermosphere • Ionosphere • Mesosphere • Energetics and Dynamics  
Flight Operations Review*

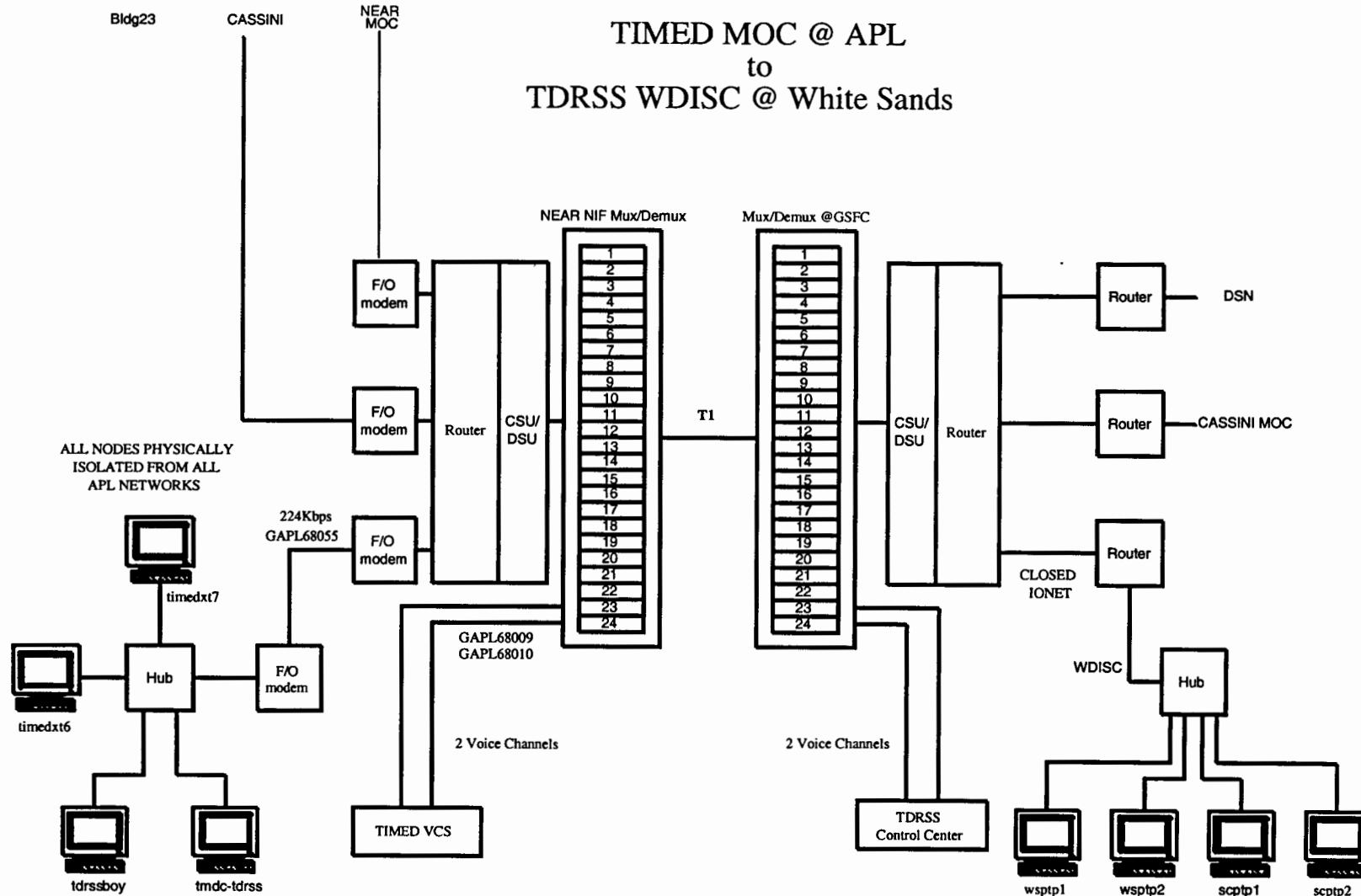

NISN will assign IP addresses for these machines

ports	port
5009 & 5010	3101





# TIMED

*Thermosphere • Ionosphere • Mesosphere • Energetics and Dynamics  
Flight Operations Review*

---



## TDRSS - Testing

- RF Compatibility Testing
  - December 15 and 17, 1999
  - Used IEM Engineering Unit as spacecraft
  - Will repeat with Spacecraft on November 21 and 28, 2000
  - Ground interface data flow testing on November 1 and 3, 2000
- Dec 1999 Results
  - *Command carrier swept acquisition threshold test was successful*
    - Performance in line with expectations.
  - *Telemetry signal threshold tests were successful*
    - Loss-of-lock threshold in line with expectations
    - Acquisition threshold only 1 dB higher than the loss-of-lock
    - The Goddard test director reported *completely successful decoding of telemetry frames.*



# TIMED

*Thermosphere • Ionosphere • Mesosphere • Energetics and Dynamics  
Flight Operations Review*

---



## TDRSS - Testing

- Dec 1999 Results (Continued)
  - *Command acceptance threshold* could not be determined
    - Spacecraft rejected all commands.
    - The good news is that the *commands were reliably rejected*
    - Indicates that the uplink bit stream was being successfully demodulated, and the CLTUs were being successfully detected
    - We suspect that the cause of rejection is incorrect formatting of the commands by the WDISC.
  - WDISC command formatting update (Oct 2000)
    - Recent analysis found that PTP software at WDISC required update
    - Following update, test command files properly formatted



# TIMED

*Thermosphere • Ionosphere • Mesosphere • Energetics and Dynamics  
Flight Operations Review*

---



## TIMED Operations Simulator (TOPS)

- “Satellite-on-the-ground”
  - Validate ops procedures, flight code updates, autonomy rule changes both pre- and post-launch.
- “Hardware-in-the-loop” simulator
  - Contains Engineering Models of critical TIMED subsystems.
    - IEM, AIU, AFC, Optional PSE/DU
  - Contains all S/C subsystem flight software.
  - Includes the subsystem GSEs needed to simulate the space environment.
  - Instruments data rates and power system are simulated
  - RF to/from APL Ground Station



# TIMED

Thermosphere • Ionosphere • Mesosphere • Energetics and Dynamics  
Flight Operations Review



## TOPS - Block Diagram

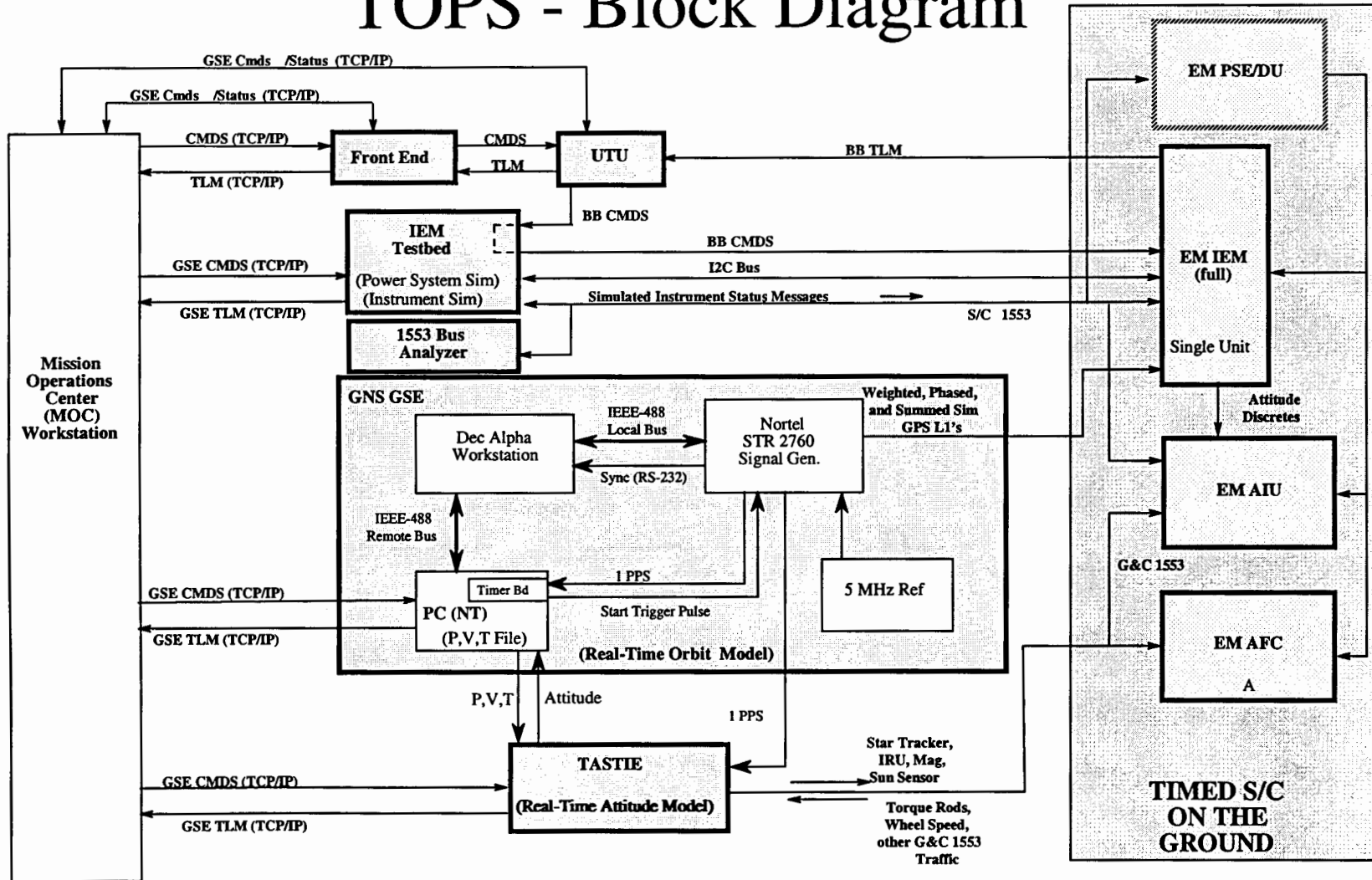



# TIMED

*Thermosphere • Ionosphere • Mesosphere • Energetics and Dynamics  
Flight Operations Review*

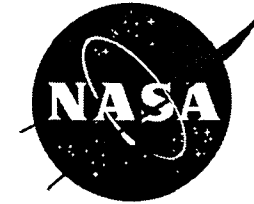

## Verification Matrix (1 of 3)

End-to-End (Instrument-to-POC) Requirements		Requirement	Verification
	System Availability	95%* [was 99%] of all Source Packets produced by the payload instruments must be collected by the spacecraft bus and delivered to the Payload Operations Centers (POCs)	
	Error Probability	Fraction of Source Packets delivered with detected and flagged errors: $1 \times 10^{-3}$	Verified by Analysis
		Fraction of Source Packets delivered with undetected errors: $1 \times 10^{-10}$	Verified by Analysis
	Data Accumulation Capacities on Spacecraft	Daily Average Housekeeping Data Rate: 5,500 b/s	By Design
		Daily Average Instrument Data Rate: 16,954 b/s	By Design
		Spacecraft Solid State Recorder (SSR) Capacity: 2.5 Gb	By Design
Space-Ground Interface		Requirement	Verification
	High Rate downlink	Dump a 1-day accumulation in a single pass at the Primary Ground Station	96-Hour Mission Simulation
		Required information rate capacity = 3,994,862 b/s	Daily testing using High Rate Downlink
	Intermediate Rate downlink	Dump a 1-day accumulation in a single cluster of passes at the Backup Ground Station	tbd - USN testing
	Low Rate downlink	Downlink real-time engineering housekeeping telemetry to a remote station	Dec 99 USN Testing
		Required information rate capacity = 9,018 b/s	Dec 99 USN Testing
	Redundancy	The TIMED Ground Station shall have a backup	Contract with USN
	Command and telemetry protocols	per CCSDS Recommendations	C&DH software design
		COP-1 protocol performed by MOC	IV&V by independent software tester
	Uplink Data Rate	Required data rate = 2,000 b/s	Daily testing using RF Uplink



# TIMED

*Thermosphere • Ionosphere • Mesosphere • Energetics and Dynamics  
Flight Operations Review*



## Verification Matrix (2 of 3)

Mission Operations (MO) Support	Requirement	Verification	
	Commands	Instrument command uploads shall be prepared at the POCs	Instrument Tests and Mission Sims
		Spacecraft [bus] commands shall be prepared in the Mission Operations Center (MOC)	Daily Testing
		[The MOC] shall collect instrument commands from POCs, and transmit them to the instruments	Instrument Tests and Mission Sims
		[The MOC] shall generate spacecraft bus commands and transmit them to the spacecraft bus.	Daily Testing
	Telemetry	Collect all [spacecraft bus and instrument] raw telemetry [in the MDC]	Daily Testing
		Analyze spacecraft bus telemetry [in the MOC]	96 Hour Mission Simulations
		Forward all raw telemetry data [to the Science Data System] for processing and distribution to POCs	Instrument Tests and Mission Sims
		Forward all science telemetry data to the instrument POCs	Instrument Tests and Mission Sims
	The MOC shall support planning and assessment		96 Hour Mission Simulations
Integration & Test (I&T) Support	Requirement	Verification	
	Support commands as indicated for MO		Daily Testing
	Support telemetry as indicated for MO		Daily Testing
	Maintain spacecraft command and telemetry dictionaries		Daily Testing



# TIMED

*Thermosphere • Ionosphere • Mesosphere • Energetics and Dynamics*

*Flight Operations Review*

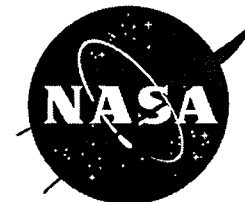

## Verification Matrix (3 of 3)

<b>Data Analysis (DA) Support</b>		<b>Requirement</b>	<b>Verification</b>
	The TIMED Science Data System (SDS) [which includes MDC and POC components] shall:	Archive and serve all raw telemetry from the start of I&T to the end of the mission	MDC Operational
		Serve all data products necessary to support the TIMED mission	96 Hour Mission Simulations
		Support transfer of data to long-term archive at the end of the mission	B-Monthly Archive process now
<b>General Ground System Requirements</b>		<b>Requirement</b>	<b>Verification</b>
	Cost-Related Constraints	The Primary TIMED Ground Station shall be selected to keep operations costs low	Local APL Ground Station
		The Mission Operations Center location shall be selected to keep operations costs low	Local APL Mission Operations Center
	Network Support	The Ground System shall include primary and backup voice and data networks for inter-facility communications during launch operations	By Design
<b>POC Service Requirements</b>		<b>Requirement</b>	<b>Verification</b>
	Commands from POC to MOC	Authentication Return Receipt	Instrument Tests and Mission Sims
	Every POC Command Message is now acknowledged with two receipts	Command Return Receipt	Instrument Tests and Mission Sims
	Telemetry from MDC to POC	Telemetry Packets	Instrument Tests and Mission Sims



# *TIMED*

*Thermosphere • Ionosphere • Mesosphere • Energetics and Dynamics  
Flight Operations Review*

---

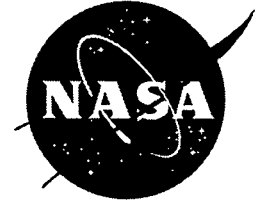

# Mission Operations Software Overview and Status

William P. Knopf  
JHU/APL  
(443) 778-6416  
[william.knopf@jhuapl.edu](mailto:william.knopf@jhuapl.edu)





# TIMED

*Thermosphere • Ionosphere • Mesosphere • Energetics and Dynamics  
Flight Operations Review*

---



## Mission Operations Software Overview

- MOPs software tools presented here are non-real time tools
  - Used for planning and assessment functions
  - Tools defined to automate manual processes
    - Verified in parallel with manual processes
- All tools have been thoroughly tested and used operationally during mission simulations (96-hour sims and Event Driven sims)



# ***TIMED***

*Thermosphere • Ionosphere • Mesosphere • Energetics and Dynamics*

*Flight Operations Review*

---



## Mission Operations Software - Overview

- Scheduler
- Parameter Archive Module
- Plot Manager
- Plotter
- Timeline
- Announcer



# TIMED

*Thermosphere • Ionosphere • Mesosphere • Energetics and Dynamics  
Flight Operations Review*

---



## Mission Operations Software – Overview (cont)

- Scheduler
  - MOC scheduling database
  - Long-term and short-term planning
  - Spacecraft milestones
  - Schedule requests for APL and USN Ground Stations
  - El-sets for APL Ground Station
  - Planned, As-flown timelines



# ***TIMED***

*Thermosphere • Ionosphere • Mesosphere • Energetics and Dynamics*

*Flight Operations Review*

---



## Mission Operations Software – Overview (cont)

- Parameter Archive Module
  - Database for GNS and G&C parameters
  - Database definitions provided through APID workbooks for selected APIDs
  - Provides engineering unit converted display of parameters loaded to spacecraft or simulator



# *TIMED*

*Thermosphere • Ionosphere • Mesosphere • Energetics and Dynamics  
Flight Operations Review*

---

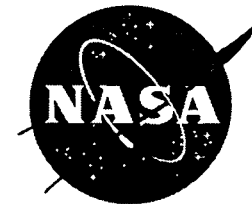

## Mission Operations Software – Overview (cont)

- Plot Manager
  - Controlling interface between Pass Manager and Plotter
  - Provides automated plotting capability for assessment process



# ***TIMED***

*Thermosphere • Ionosphere • Mesosphere • Energetics and Dynamics  
Flight Operations Review*

---



## Mission Operations Software – Overview (cont)

- Plotter
  - Interfaces with Plot Manager for automated generation of user-defined routine plots for assessment
  - May be started with Graphical User Interface to generate customized plots and plot definitions



# TIMED

*Thermosphere • Ionosphere • Mesosphere • Energetics and Dynamics*  
*Flight Operations Review*

---

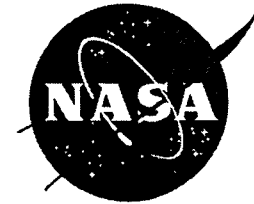

## Mission Operations Software – Overview (cont)

- Timeline
  - Allows generation of graphical daily timeline
  - The timeline contains the following:
    - Contact times (AOS, LOS, Station ID)
      - Scheduled, Available, Primary, Backup
    - Eclipse (penumbra, umbra) entry/exit
    - Polar region entry/exit
    - South Atlantic Anomaly entry/exit
    - Equator crossings
    - Special events (yaw maneuver, processor load, etc.)
  - Interfaced to Scheduler



# *TIMED*

*Thermosphere • Ionosphere • Mesosphere • Energetics and Dynamics  
Flight Operations Review*

---



## Mission Operations Software – Overview (cont)

- Announcer
  - Provides automated announcements over voice network
  - Interfaced to Scheduler
  - Announces time to contact AOS, time remaining in contact, contact LOS at various intervals





# TIMED

*Thermosphere • Ionosphere • Mesosphere • Energetics and Dynamics  
Flight Operations Review*



## Mission Operations Software Status

Tool Name	Status	Operational Date	Comments
Scheduler	Operational	04/1999	
PAM	In Test	11/10/2000	Final testing during upcoming 96-hour mission simulation
Plot Manager	Operational	09/2000	
Plotter	Operational	09/2000	Some user enhancements requested; not mission critical
Timeline	Operational	09/1999	
Announcer	Operational	11/1999	



# ***TIMED***

*Thermosphere • Ionosphere • Mesosphere • Energetics and Dynamics  
Flight Operations Review*

---



## Phase E Staffing

David G. Grant

TIMED Program Manager

# Roles and Responsibilities

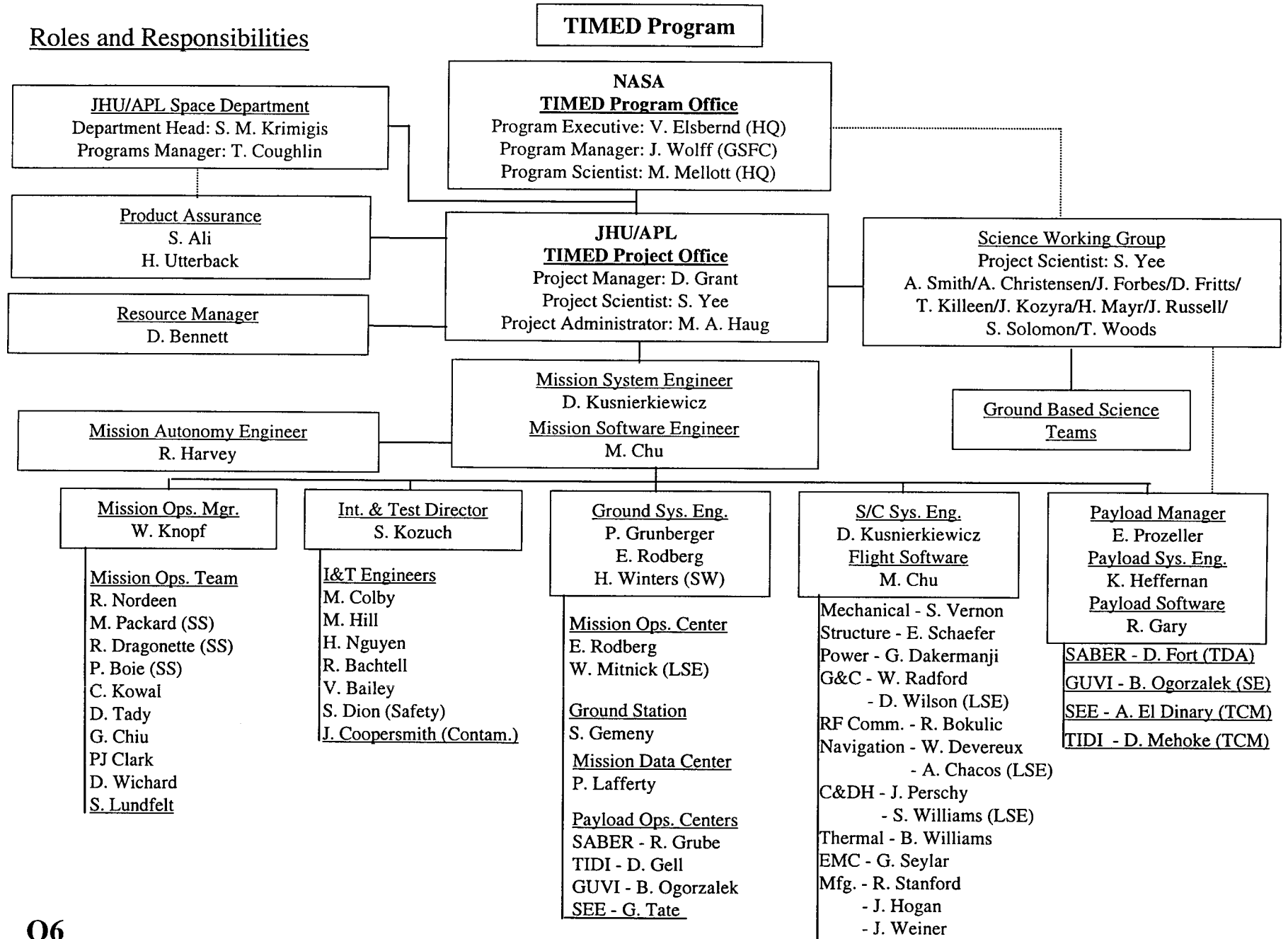



# TIMED Program - Phase E

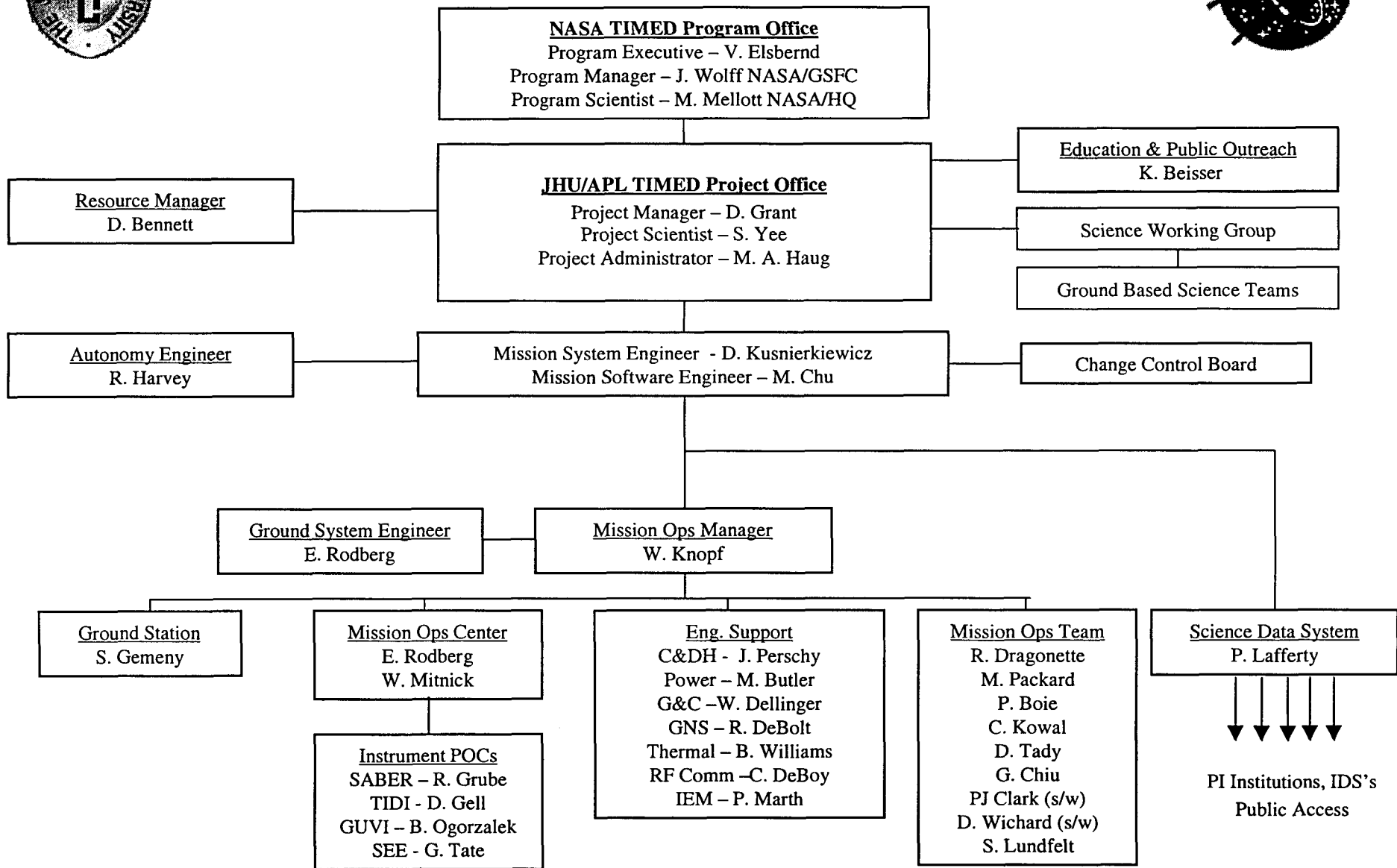

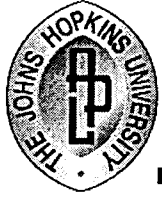

# ***TIMED***

*Thermosphere • Ionosphere • Mesosphere • Energetics and Dynamics  
Flight Operations Review*

---



## **On-Orbit Missions Operations Team**

- **Three teams of two spacecraft operators**
  - **Spacecraft Control Team**
    - Two teams conduct daily operations (7 days/week)
    - Four 10 hour days on, 3 days off
  - **Planning and Analysis Team**
    - Supports advanced planning and comprehensive performance assessment activities
    - Five 8 hour days, Monday through Friday
  - Teams rotate positions every four weeks
- **Two person ground system support team provides**
  - Software support
  - System administration and management
  - General ground system maintenance



TIMED Program – Phase E  
Change Control Board

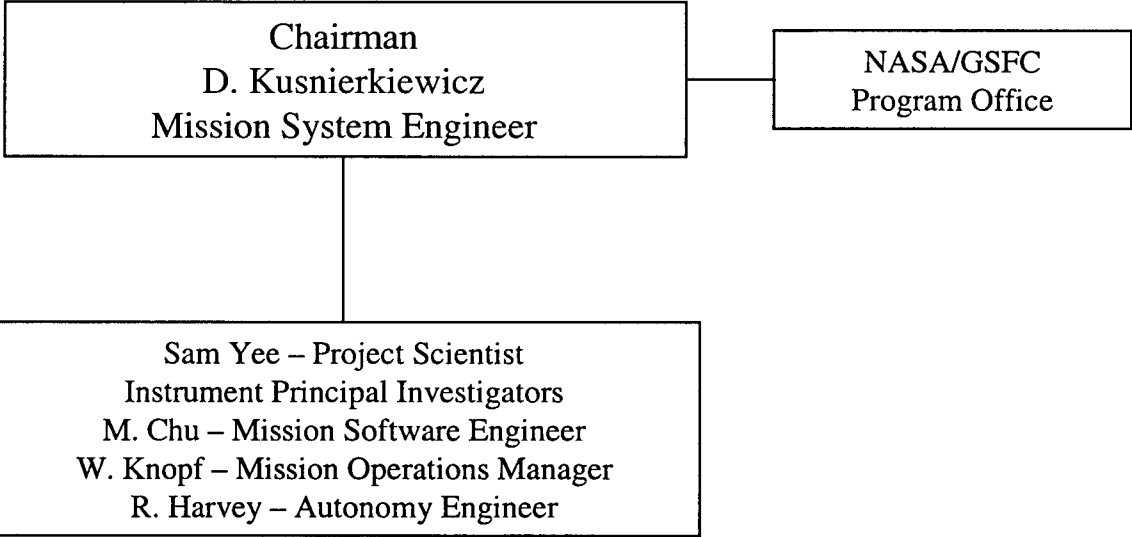

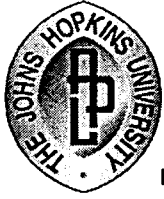

# ***TIMED***

*Thermosphere • Ionosphere • Mesosphere • Energetics and Dynamics  
Flight Operations Review*

---



## Operations Training

Richard Dragonette



# ***TIMED***

*Thermosphere • Ionosphere • Mesosphere • Energetics and Dynamics  
Flight Operations Review*

---



## Mission Operations Training (1/5)

- Based on MSX Operations Planning Training
  - Many of the same people involved
  - Worked well
  - Handled 100% turn over in first year
- Simultaneous Training in Real-time Contact Operations and Advanced Planning Operations





# TIMED

*Thermosphere • Ionosphere • Mesosphere • Energetics and Dynamics  
Flight Operations Review*

---



## Mission Operations Training (2/5)

- TIMED Mission Operations Consists of 3 Teams of 2 People
  - 2 teams conduct Real-time contacts 7 days a week
  - 1 team conducts advanced planning Mon-Fri
- New Personnel Assigned to Advanced Planning Team
  - Advanced planning is learned working with the experienced advanced planning team member
  - Real-time contact conduct is observed during contacts



# TIMED

*Thermosphere • Ionosphere • Mesosphere • Energetics and Dynamics  
Flight Operations Review*

---



## Mission Operations Training (3/5)

- Advanced Planning Training
  - Consists of weekly planning and daily planning
  - Does not require 2 people full time, so time available to train and to complete required functions
  - All functions detailed in Standard Operating Procedures documents,
  - All functions also summarized in the daily planning and weekly planning checklists



# ***TIMED***

*Thermosphere • Ionosphere • Mesosphere • Energetics and Dynamics  
Flight Operations Review*

---



## Mission Operations Training (4/5)

- Real-Time Contact Operations
  - Observed by trainee during TIMED contacts
  - Practiced with mission operations team members using simulations on the TOPS spacecraft simulator
    - Uses real contact scripts generated by planning tools
    - Uses real ground station hardware and telemetry
    - Uses simulated spacecraft telemetry for the TOPS system
      - TOPS has engineering model hardware of all spacecraft bus subsystems



# *TIMED*

*Thermosphere • Ionosphere • Mesosphere • Energetics and Dynamics  
Flight Operations Review*

---



## Mission Operations Training (5/5)

- Supporting Documentation
  - Operations handbook written by current mission operations team members
  - Spacecraft bus subsystem operators guides written by experienced team members (G&C, GNS, C&DH and Power)
  - Planning functions specified in existing standard operating procedures



# ***TIMED***

*Thermosphere • Ionosphere • Mesosphere • Energetics and Dynamics  
Flight Operations Review*

---



## Mission Operations Training Summary

- Training Plan Based On the Successful MSX Operations Planning Training Plan
- Trainees certified by planning and executing contacts for 2 weeks on the TOPS simulator
- Expect No Problems



# ***TIMED***

*Thermosphere • Ionosphere • Mesosphere • Energetics and Dynamics  
Flight Operations Review*

---



## Contingency Plan Review

Richard Dragonette

[richard.dragonette@jhuapl.edu](mailto:richard.dragonette@jhuapl.edu)

443-778-5085



# ***TIMED***

*Thermosphere • Ionosphere • Mesosphere • Energetics and Dynamics  
Flight Operations Review*

---



## TIMED Contingency Overview

- Spacecraft is highly autonomous
  - Detects most anomalies
  - Safes itself
  - Sets telemetry alarms to alert operations that the anomaly has occurred
- Operations concept calls for 1 contact a day after the early operations period



# TIMED

*Thermosphere • Ionosphere • Mesosphere • Energetics and Dynamics  
Flight Operations Review*

---



## Contingency Plan Overview

- Contact time is limited, so use alarmed spacecraft telemetry to initiate contingency procedure responses
- Automated system to search downlinked SSR telemetry for spacecraft alarms post contact
- Contingency Response Plan
  - Based on a alarmed telemetry, either real-time or post pass playback
  - Safe the spacecraft on the contact the anomaly is detected
  - Confer with mission operations team and spacecraft engineering team if required
  - Call for contingency contacts as required
  - Initiate contingency recovery script specified in the contingency plan
  - Enter information in anomaly database





# ***TIMED***

*Thermosphere • Ionosphere • Mesosphere • Energetics and Dynamics  
Flight Operations Review*

---



## TIMED Contingency Plan Document

- INCLUDES:
  - Responses to All Telemetry Alarms
  - Responses to All Rule Based Fault Autonomy Rules
  - Spacecraft Contingency Plans
    - Arranged by Subsystem
  - Contingency Plan Development Matrix



# TIMED

*Thermosphere • Ionosphere • Mesosphere • Energetics and Dynamics  
Flight Operations Review*

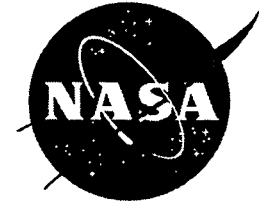

## Response to Alarms

Mnemonic	Description	Red Low	Yellow Low	Yellow High	Red High	Response
G1_CMDS_REJ_006	Commands Rejected	-0.5	-0.5	0.5	0.5	Refer to the GNS Command Error Alarm Response: Contingency Procedure 3.7.7
G1_GPSTIME_004	GPS Time CUC	6E+08	6E+08	8E+08	8E+08	Refer to the GNS Time Error Alarm Response: Contingency Procedure 3.7.9
G1_GTA_AGC_007	GTA AGC Value	2280	2280	3050	3050	Refer to the GNS AGC/Oscillator Error Alarm Response: Contingency Procedure 3.7.10
G1_POSX_006	Position X CIS	-2E+07	-8000000	8000000	20000000	Refer to the GNS Navigation Solution Error Alarm Response: Contingency Procedure 3.7.8
G1_POSY_006	Position Y CIS	-2E+07	-8000000	8000000	20000000	Refer to the GNS Navigation Solution Error Alarm Response: Contingency Procedure 3.7.8
G1_POSZ_006	Position Z CIS	-2E+07	-8000000	8000000	20000000	Refer to the GNS Navigation Solution Error Alarm Response: Contingency Procedure 3.7.8



# TIMED

*Thermosphere • Ionosphere • Mesosphere • Energetics and Dynamics  
Flight Operations Review*

---



## Response to Fault Autonomy Rules

- Autonomy Divided into 3 Types
  - ① Embedded
    - Built into Subsystem Application Software
    - If MOT Response Required, either a telemetry alarm will be set, or a Fault Autonomy Rule Fires to Alert MOT to Occurrence
  - ② Rule Based Maintenance
    - No Response Required.
    - Part of the Normal Operation of the Spacecraft
  - ③ Rule Based Fault
    - Indicates a Spacecraft Fault Condition Requiring MOT Response
    - Each Rule has a Specific Response Listed in the Contingency Plan Document



# ***TIMED***

*Thermosphere • Ionosphere • Mesosphere • Energetics and Dynamics  
Flight Operations Review*

---



## Contingency Plan Outline

### ■ X.Y.Z: Contingency Plan X.Y.Z Name

#### ◆ SECTION I DIAGNOSIS AND INDICATIONS

- Section I-A Associated Telemetry

spacecraft telemetry associated with the detecting and response to the contingency

- Section I-B Associated Autonomy Rules

lists any autonomy rules related to the contingency

- Section I-C Symptoms and Diagnosis Criteria

lists the indications that will alert mission operations to the occurrence of the anomaly that requires the execution of this contingency procedure.



# ***TIMED***

*Thermosphere • Ionosphere • Mesosphere • Energetics and Dynamics  
Flight Operations Review*

---



## ■ X.Y.Z: Contingency Plan X.Y.Z Name

### ◆ SECTION II RESPONSE TO CONTINGENCY

- Section II-A Response Steps

Detailed description of the contingency response. Includes safing the spacecraft, telemetry analysis, and the steps required to return the spacecraft to normal operations

- Section II-B Further Analysis

Description of additional analysis to be performed upon completion of the contingency plan steps

- Section II-C Supplemental Information

Contains additional background information that the contingency plan author may want to provide



# ***TIMED***

*Thermosphere • Ionosphere • Mesosphere • Energetics and Dynamics*

*Flight Operations Review*

---



## Contingency Plan Development Matrix

- Used to track the completion status of all TIMED spacecraft contingency plans
  - Lists all TIMED contingency plans
  - Sorted by subsystem, and by plan number within each subsystem
  - tracks completion status of the written plan
  - tracks status of testing of the plan on TOPS and/or the spacecraft
  - lists the plan name, description, and author



# TIMED

*Thermosphere • Ionosphere • Mesosphere • Energetics and Dynamics  
Flight Operations Review*



#	Priority	Contingency Plan Name	More Detailed Description	Sub-systems Involved	Contingency Plan Document Section
<b>G&amp;C Contingencies</b>					3.3
A1	High	Recovery from a G&C Sun Safe pointing mode initiated within the G&C Subsystem		AIU/Mode management	3.3.1.1
A2	High	Recovery from a G&C Nadir mode initiated within the G&C Subsystem		AIU/Mode management	3.3.1.2
A3	High	AIU Reboot	Response to an AIU reboot including uplinking the current configuration script	AIU	3.3.2.1
A4	High	Manually Switch AIUs - this will be a backup to on-board autonomy rules	Switch AIU's manually, either due to a failure of to test the redundant system. Includes altering autonomy and command dictionary if an AIU is declared permanently offline.	AIUs and anything which needs to be notified of switch	3.3.2.2
A5	High	Recovery from an Autonomous AIU Switch	Includes steps to be taken by mission operations after an autonomy rule has switched AIUs	AIU	3.3.2.3
A6	Medium	Manually Switch IRUs	Requires a series of commands to convince the AIU to switch IRU's. There is no direct IRU switch command.	AIU/IRUs	3.3.2.4



# TIMED

*Thermosphere • Ionosphere • Mesosphere • Energetics and Dynamics  
Flight Operations Review*



#	Priority	Contingency Plan Name	More Detailed Description	Sub-systems Involved	Contingency Plan Section
A7	High	Failed Wheel removal from control algorithm and autonomy rule modifications	Remove a failed wheel from the control algorithm (this will be done autonomously within G&C - may want contingency procedure as a backup). Some autonomy rules will be modified in response to a failed wheel.	AIU	3.3.2.5
A8	Medium	Momentum Management Problem	This may turn out to be driven by an ALARM which indicates a problem. This procedure could be the one we run when the alarm goes red. Includes problems with torque rods and/or magnetometers.	AIU	3.3.2.6
A9	Medium	Solar Array Commanding problem as reported by the AIU	may indicate failed SA drive; may require AIU switch to, in essence, switch drives. ALARM: G&C Housekeeping: SA Wing +X and -X Commanded Position status (work 4 bits 5 and 4 respectively). Set to a one when "commanding problem (after time-out did not	Power AIU	3.3.2.7
A10	Low	Mask Soft LVS in AIU	Mask Soft LVS using "override" in AIU - for the case of a Failed Soft LVS discrete from C&DH to AIU.	AIU	3.3.2.8
A11	Low	Mask Hard LVS	Mask Hard LVS discrete using relay command for launch and failed Hard LVS discrete.	AIU	3.3.2.9
A12	Low	Loading new Sun Safe Vector and Solar Array Angles into AIU	Failure to load properly and with accurate information, could lead to loss of mission	AIU	3.3.2.10
A13	Low	Subsystem Command Ability failure	AIU	AIU	3.3.2.11





# TIMED

*Thermosphere • Ionosphere • Mesosphere • Energetics and Dynamics  
Flight Operations Review*

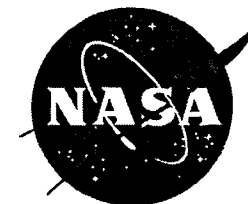

#	Priority	Contingency Plan Name	More Detailed Description	Sub-systems Involved	Contingency Plan Section
A14		Solar Array Manual rotation sequence		AIU	3.3.2.12
A15		Switch Torque Rod Coils		AIU	3.3.2.13
A16		Switch Magnetometers		AIU	3.3.2.14
A17		Recovery from Autonomous Magnetometer Switch		AIU	3.3.2.15
A18	High	AFC Reboot Recovery and Low memory Dump	After a reset, the AFC Low Memory is dumped because it contains data which may indicate the reset cause	AFC	3.3.3.1
A19	High	Switch AFCs - this will be a backup to on-board autonomy rules	Switch AFC's manually, either due to a failure of to test the redundant system. Includes altering autonomy and command dictionary if an AFC is declared permanently offline.	AFCs and anything which needs to be notified of the switch	3.3.3.2
A20	Low	Subsystem Command Ability failure	AFC	AFC	3.3.3.3



# TIMED

*Thermosphere • Ionosphere • Mesosphere • Energetics and Dynamics  
Flight Operations Review*



#	Priority	Contingency Plan Name	More Detailed Description	Sub-systems Involved	Contingency Plan Section
<b>Power Subsystem Contingencies</b>					3.4
P1	High	Recovery from Soft LVS #1 Sequence	Turns on instruments and brings them to their Normal Data Collection modes, including the decision process leading up to the decision to return to normal operating mode.	All Subsystems/Instruments	3.4.1
P2	High	Recovery from Soft LVS #2 Sequence	Remain on other AIU?; Ready to go operational again?; Go to Operational Pointing and power up and configure instruments for NSDC.	All Subsystems/Instruments	3.4.2
P3	High	Recovery from Hard LVS Sequence	Bring up IEM; etc...Reset the Hard LVS disable function (re-enable Hard LVS by ground command)	All Subsystems/Instruments	3.4.3
P4	High	Switch the battery control from PPT to V-T or vice versa	Most likely will occur at the direct request of power system engineers	C&DH/Power	3.4.5.1
P5	Medium	Switch PSE/DUs	Includes commands to switch, and flow chart to determine a PSE/DU has failed	Power/C&DH	3.4.5.2



# TIMED

*Thermosphere • Ionosphere • Mesosphere • Energetics and Dynamics  
Flight Operations Review*



#	Priority	Contingency Plan Name	More Detailed Description	Sub-systems Involved	Contingency Plan Section
P6	Low	Coulometer Reset	Consists of sending a single command at the request of the power system engineer based on their analysis of telemetry	Power/C&DH	3.4.5.3
P7	Low	Peak Power Tracker Reset	Consists of sending a single command at the request of the power system engineer based on their analysis of telemetry	Power/C&DH	3.4.5.4
P8	Low	Set Coulometer Count	Requires the power system engineering team to develop a table correlating battery pressure to coulombometer counts	Power/C&DH	3.4.5.5
P9	Low	Change C/D ratio	Consists of sending a single command at the request of the power system engineer based on their analysis of telemetry	Power/C&DH	3.4.5.6
P10	Low	Change Battery Charge Rate - High/Trickle	Consists of sending a single command at the request of the power system engineer based on their analysis of telemetry	Power/C&DH	3.4.5.7
<b>IEM Contingencies</b>					<b>3.5</b>
I1	High	IEM Failure Detection and IEM Switch over procedure	There is a hierarchy of problems which could result in an IEM problem. There needs to be a thought-out plan for determining what the cause of the problem is. Perhaps this plan will do that.	IEM	3.1.1



# TIMED

*Thermosphere • Ionosphere • Mesosphere • Energetics and Dynamics  
Flight Operations Review*



#	Priority	Contingency Plan Name	More Detailed Description	Sub-systems Involved	Contingency Plan Section
<b>C&amp;DH Contingencies</b>					3.6
C1	High	C&DH Reset Recovery Procedure	Includes steps to dump low memory and verify C&DH current configuration		3.6.1
C2	High	Response to Autonomy Detected C&DH Anomalies	Some autonomy rules store specific data to the SSRs when they fire. The procedure lists steps to locate and recover this data	C&DH	3.6.2
C3	Medium	Dump of C&DH error buffers	When a C&DH error is detected (command delivery error, cmd execute error etc) C&DH buffers need to be dumped and reviewed	C&DH	3.6.3
C4	Medium	Response to C&DH error telltale alarms	When a C&DH error telltale alarm is detected C&DH buffers need to be dumped and reviewed	C&DH	3.6.4
C5	Low	Subsystem Command Ability failure	C&DH	C&DH	3.6.5
C6	Medium	Command Delivery Failure	May be detection only, unless there is specific response	C&DH	3.6.6



# TIMED

*Thermosphere • Ionosphere • Mesosphere • Energetics and Dynamics  
Flight Operations Review*

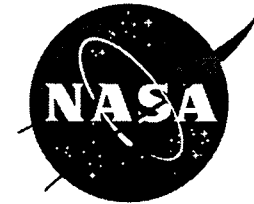

GNS Contingencies					3.7
G1	High	GNS Navigation Processor Reboot	GNS - recovery procedure and low memory dump	GNS	3.7.1
G2	High	GNS Tracking Processor Reboot	GNS - current configuration script	GNS	3.7.2
G3		GNS Navigation Processor Loads after an Application Software Load	If segments 11,12,14,15 are reloaded through the boot, these GNS parameter blocks need to be modified after the load using these commands	GNS	3.7.3
G4	Medium	GNS Not Tracking GPS satellite Constellation	Describes steps to take to examine telemetry to determine the cause of the GNS inability to track the GPS constellation	GNS	3.7.4
G5	Low	Subsystem Command Ability failure	Steps to take if the GNS can no longer accept commands	GNS	3.7.5
G6	Medium	GNS Not outputting telemetry	GNS outputs telemetry according to a regular schedule, if some or all of this telemetry fails to appear this contingency plan determines why and fixes it	GNS	3.7.6
G7	Medium	GNS Command Error Alarm Response	Response to a command reject error or other command error	GNS	3.7.7
G8	Medium	GNS Navigation Solution Error Alarm Response	Response to an error in the GNS navigation solution other than the FOMs going out of bounds		3.7.8
G9	Medium	GNS Time Error Alarm Response	Response to an alarm indicating a GNS reported problem with its knowledge of time		3.7.9
G10	Medium	GNS AGC/Oscillator Out of Operating Bonds Alarm Response	Response to GNS reporting that the receiver AGC or internal oscillator frequency offset have exceeded operating bounds		3.7.10
G11	Medium	GNS FOM Error Alarm Response	Response to an alarmed GNS Figure of Merit (FOM) in telemetry		3.7.11



# TIMED

*Thermosphere • Ionosphere • Mesosphere • Energetics and Dynamics*

## *Flight Operations Review*

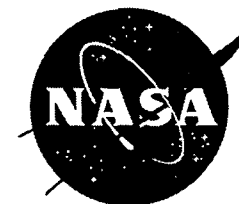

#	Priority	Contingency Plan Name	More Detailed Description	Sub-systems Involved	Contingency Plan Section
<b>RF Subsystem Contingencies</b>					3.8
R1	High	Blind Acquisition	- turns on S/C telemetry when AOS was not expected (unscheduled contact)	RF, C&DH,	3.2.1
R2	High	Negative Acquisition -	turns on S/C telemetry when expected AOS does not occur	RF, C&DH,	3.2.2
R3	Medium	Switch RF Configuration from low rate to high rate and vice versa	Turn-off transmitters, switch configuration, then turn the same back on. Spacecraft macros have been implemented to handle this contingency. Macro 104 switches hi to low, and 105 switches low to hi	RF	3.2.3
R4	Low	Detect that a transmitter is stuck on.	Try shutting it down by shutting off the IEM it is connected to. There is a relay which could fail which is outside of the IEM and in that case, when not in contact, we can only put the transmitter in "omni" configuration so that the signal strength decr	RF/IEM	3.2.4
R5	Low	Both S/C Transmitters Powered - There will be an autonomy rule implemented to make sure this does not happen. If it happens while Autonomy is not working, there may need to be a contingency plan for it.	Detect that both S/C transmitters are powered, and power off the #2 (or #1 if #2 is now prime). The detection part may be tricky, since both signals will be received on the ground. The data will be garbled. Someone should be able to detect a problem by	RF	3.2.5



# TIMED

*Thermosphere • Ionosphere • Mesosphere • Energetics and Dynamics  
Flight Operations Review*



#	Priority	Contingency Plan Name	More Detailed Description	Sub-systems Involved	Contingency Plan Section
14		<b>Instrument Contingency Plans which Affect the Spacecraft Bus</b>	<b>Includes only things which affect the bus like over-current, heater failure etc. Excludes plans internal to an instrument such as sensor reconfiguration</b>		3.8
S1	High	Warn and Shut-down the SABER instrument	• SABER	C&DH/ SABER	3.8.1
S2	High	Warn and Shut-down the SEE instrument	• SEE	C&DH/ SEE	3.8.2
S3	High	Warn and Shut-down the GUVI instrument	• GUM	C&DH/ GUVI	3.8.3
S4	High	Warn and Shut-down the TIDI instrument	• TIDI	C&DH/ TIDI	3.8.4



# TIMED

*Thermosphere • Ionosphere • Mesosphere • Energetics and Dynamics  
Flight Operations Review*

---

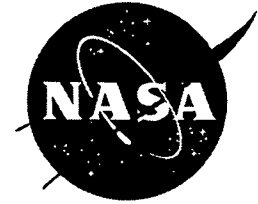

## Contingency Plan Completion Status

- G&C 7/20 in draft
- Power 10/10 in complete(7) or in draft(3)
- C&DH 4/6 complete
- GNS 7/11 complete(3) or in draft(4)
- RF 3/5 complete(2) or in draft(1)
- Instruments 4/4 complete
- Completion status delayed by additional heavy test schedule during July and August added to the mission operations team since the MOR to support the December 2000 launch date.





# ***TIMED***

*Thermosphere • Ionosphere • Mesosphere • Energetics and Dynamics  
Flight Operations Review*

---



## Contingency Plan Test Approach

- Develop spacecraft macros if required (such as a switch to the backup AFC) and test
- Draft the STOL script to implement the contingency plan response
- Start a nominal simulation on the spacecraft or on TOPS
  - TOPS is used to test temperature/current anomalies because temperatures and currents can be specified by ground command through the IEM test-bed
- Induce the anomaly, and run the recovery STOL script
- Iterate the STOL script until satisfactory



# TIMED

*Thermosphere • Ionosphere • Mesosphere • Energetics and Dynamics  
Flight Operations Review*

---



## Contingency Plan Testing Status

- Power All procedures have been tested. 7/10 tested as part of baseline performance. The other 3 have been tested as part of LVSS recovery simulations
- Instruments All 4 instrument power down procedures used routinely during mission sims to power down
- RF 3/5 tested. Negative acquisition, blind acquisition, and real-time telemetry rate switches have been tested on the spacecraft
- GNS 6/11 GNS procedures tested on the spacecraft



# *TIMED*

*Thermosphere • Ionosphere • Mesosphere • Energetics and Dynamics  
Flight Operations Review*

---



## Contingency Plan Testing Status (continued)

- G&C Tested 2/20 procedures
- Also have tested on-board spacecraft macros that switch to the redundant AIU and AFC. These macros are used by a number of G&C contingency plans to respond to a failed AIU, AFC, or solar array drive component
- G&C spacecraft specialist has manually performed the actions required for the response to G&C contingencies on the spacecraft or TOPS, the documentation needs to be completed



# ***TIMED***

*Thermosphere • Ionosphere • Mesosphere • Energetics and Dynamics  
Flight Operations Review*

---



## Summary

- Effective 9/15, added two new people to relieve the mission ops team work load
- I&T test conductors are helping to write some procedures
- The list of plans is comprehensive, and is the result of the many hours spent operating and testing the spacecraft
- Weekly status meetings requesting status of all plans assigned to each author
- I provide constant encouragement to the authors to complete plans between meetings
- Ample test time set aside during December/January for mission operations testing



# *TIMED*

*Thermosphere • Ionosphere • Mesosphere • Energetics and Dynamics  
Flight Operations Review*

---



## *Ground System Contingencies*

Elliot Rodberg

Phone: 240-228-5318

e-mail: [elliott.rodberg@jhuapl.edu](mailto:elliott.rodberg@jhuapl.edu)

The Johns Hopkins University  
Applied Physics Laboratory  
Laurel, Maryland 20723



# ***TIMED***

*Thermosphere • Ionosphere • Mesosphere • Energetics and Dynamics  
Flight Operations Review*

---



## Ground System Contingency Overview

- Contingencies grouped by subsystem
  - MOC, MDC, Ground Station
- Spare or backup systems for all critical hardware
- Backup systems for all critical software
- Many contingencies only require change to configuration of software or hardware element
- A few contingencies require moving or replacing hardware



# TIMED

*Thermosphere • Ionosphere • Mesosphere • Energetics and Dynamics  
Flight Operations Review*



## TIMED Ground System Components

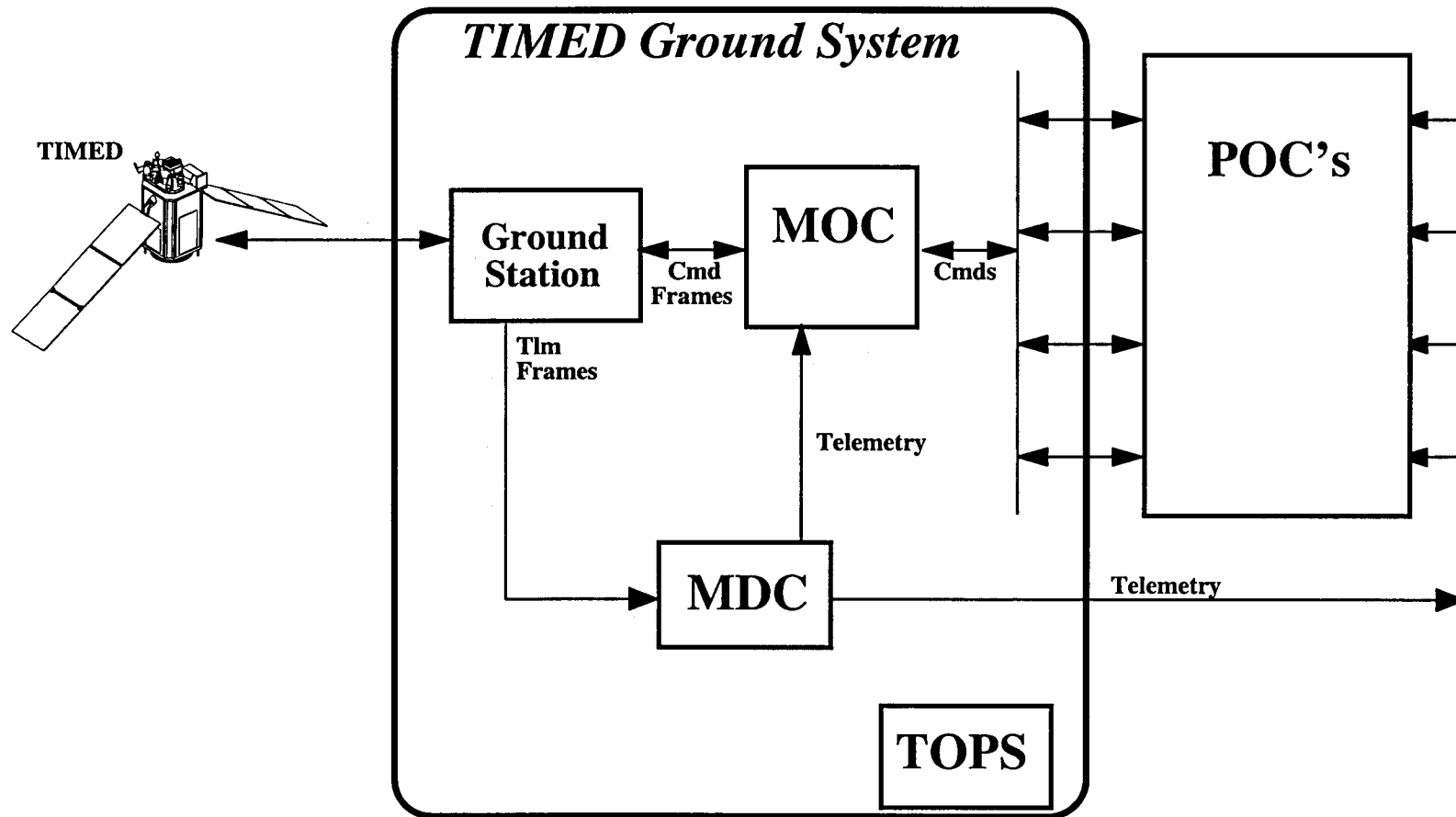



# TIMED

*Thermosphere • Ionosphere • Mesosphere • Energetics and Dynamics  
Flight Operations Review*



## TIMED Flight Ground System

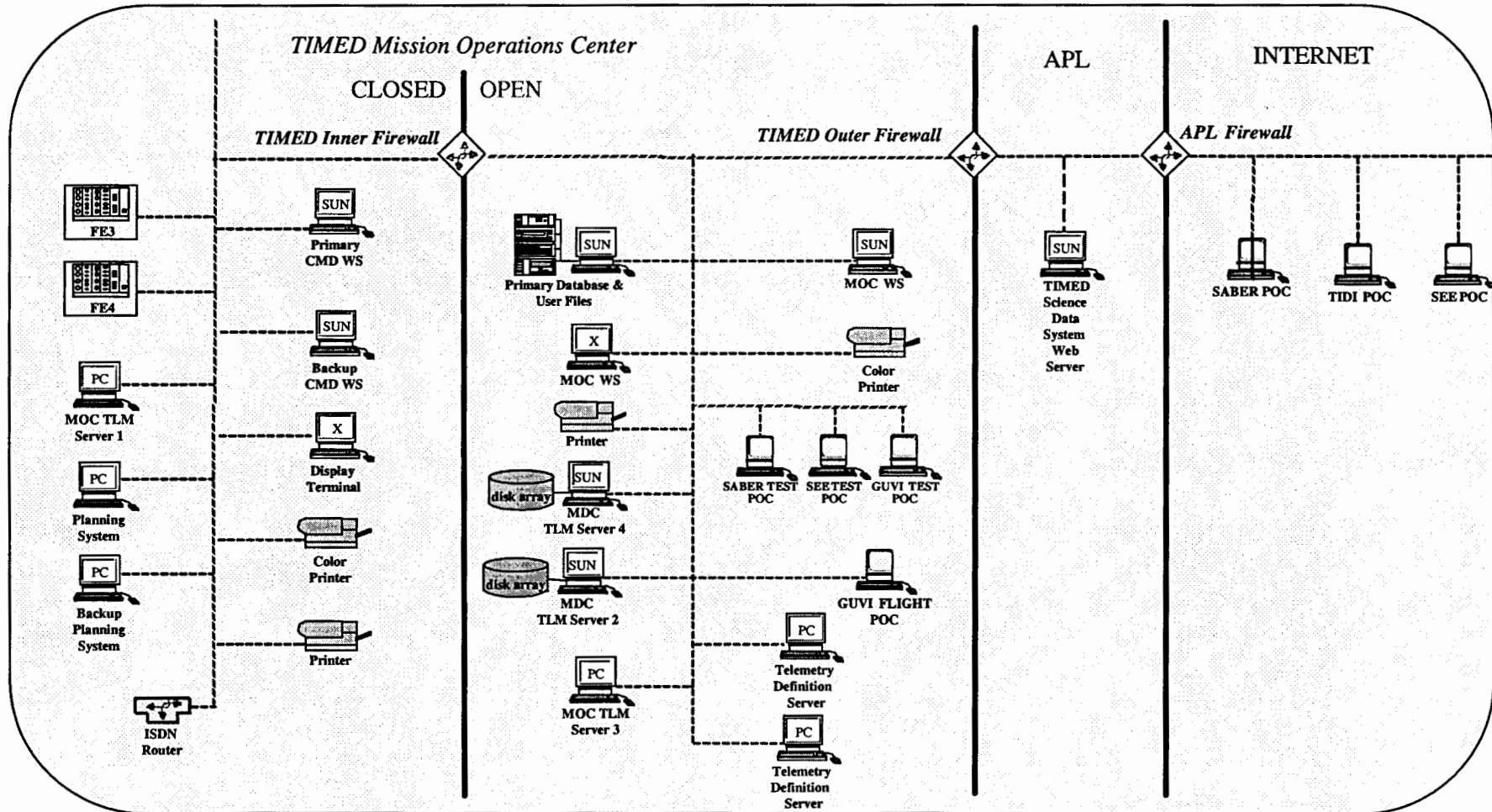





# TIMED

Thermosphere • Ionosphere • Mesosphere • Energetics and Dynamics

Flight Operations Review

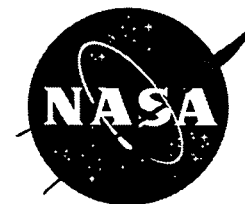

## APL TIMED Ground Station - Downlink System

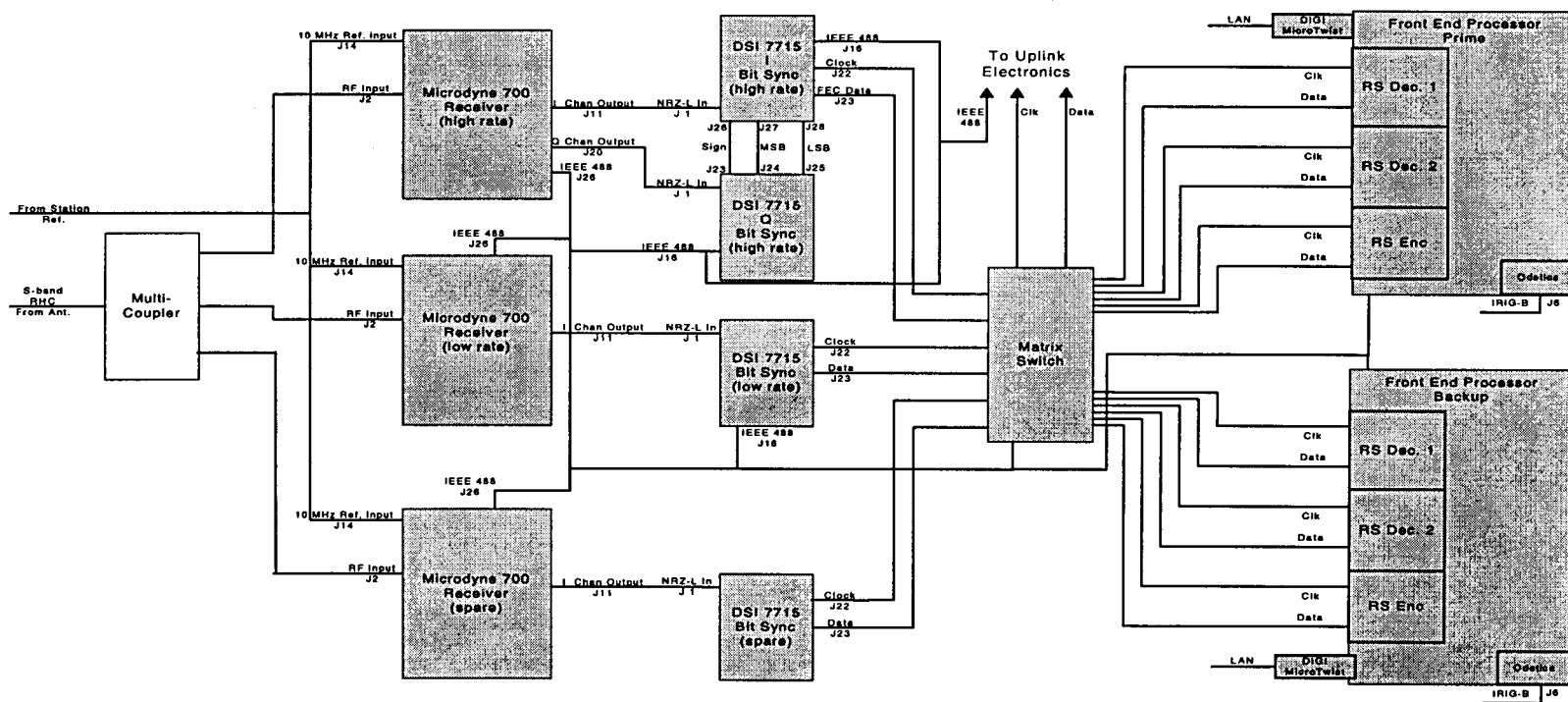



# TIMED

Thermosphere • Ionosphere • Mesosphere • Energetics and Dynamics  
Flight Operations Review



## APL TIMED Ground Station - Uplink System

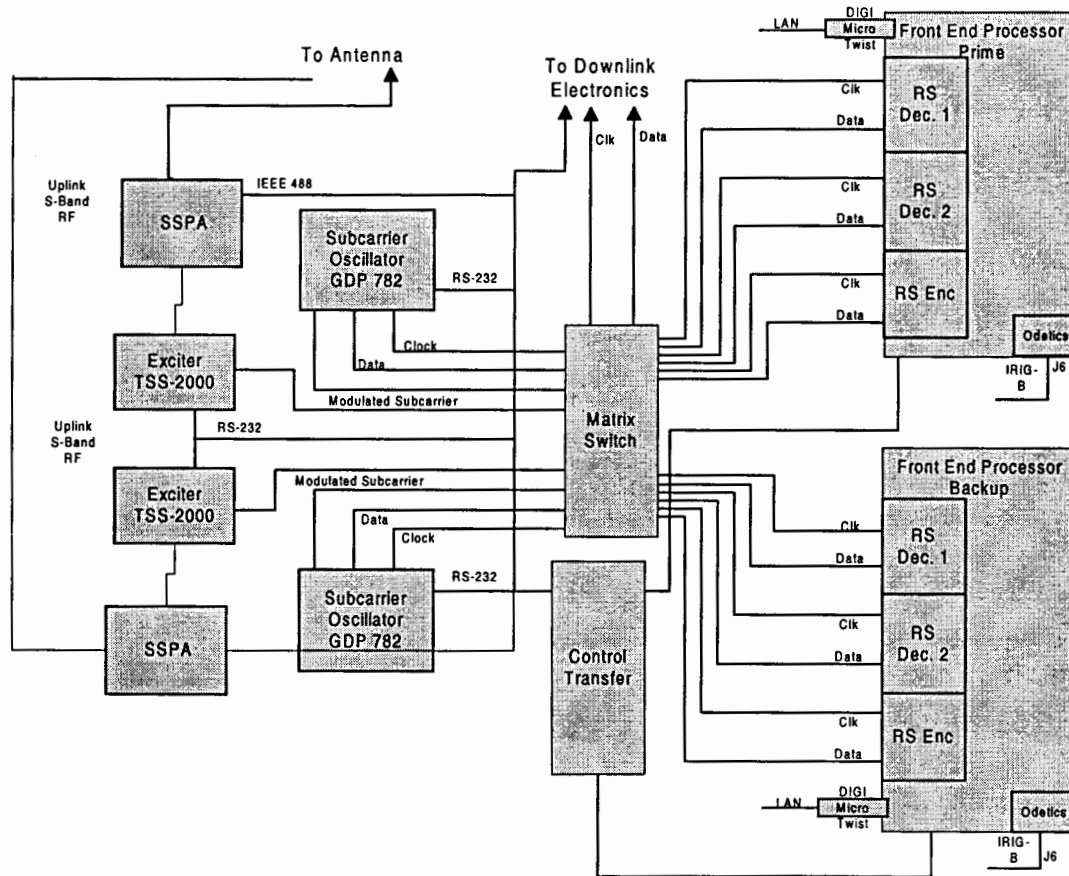

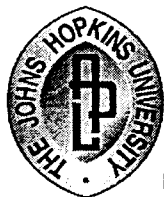

# TIMED

*Thermosphere • Ionosphere • Mesosphere • Energetics and Dynamics  
Flight Operations Review*

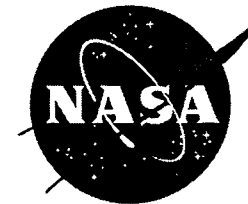

## MOC Contingencies

<b>Problem</b>	<b>Planned Solution</b>	<b>Time to Implement</b>	<b>Procedure Tested</b>
Primary Command workstation (ralph) fails	Switch to Backup Command workstation (alf)	5 minutes	10/12/00
Backup Command workstation (alf) fails	Move RAID disk controller cable to Primary workstation (ralph)	1 hour	Oct-99
MOC real-time software failure	Revert to previous version of software	15 minutes	7/31/00
Database flatfile problem	Revert to previous database flatfile	10 minutes	10/26/00
Planning system PC fails	Switch to Backup Planning system PC	5 minutes	
Internet link to POCs fails	Switch to modem connections to POCs	5 minutes	week of Oct 23
Network equipment failure	Contact network support team, switch to spare network equipment	1 hour	
Oracle database system failure	Switch to backup Oracle system	2 hours	Jul-00



# TIMED

*Thermosphere • Ionosphere • Mesosphere • Energetics and Dynamics  
Flight Operations Review*



## MDC Contingencies

<b>Failure type</b>	<b>Contingency</b>	<b>Time to Implement</b>	<b>Procedure Tested</b>
tmdc-ts1 telemetry server failure	LEOPS - switch to tdrss-mdc computer Later - switch to tmdc-ts3		
tmdc-ts5 telemetry server failure	Reconfigure front end and tmdc-ts1 to send data to tmdc-ts2	1 hour	Plan to test Nov 7 or 8
	If long term failure, then move disk farm to tmdc-ts4, reconfigure front end and tmdc-ts1 to send data to tmdc-ts4	1 day	Plan to test Nov 8 or 9



# TIMED

*Thermosphere • Ionosphere • Mesosphere • Energetics and Dynamics  
Flight Operations Review*



## Ground Station Contingencies (1 of 2)

System	Problem	Planned Solution	Time to Implement	Procedure Tested
FE 3	Blind Acquisition	Sweep uplink, don't wait for telemetry	seconds	10/12/00
FE 3	Primary command workstation failure	Command from backup workstation	1 minute	10/12/00
FE 3	Autonomous data rate change from 4mb to 10k	No action required	immediate	10/12/00
FE 3	Autonomous data rate change from 10k to 4mb	No action required	immediate	10/12/00
	Failure of Front End 3	Switch to Front End 4	10 minutes	10/12/00
FE 4	Blind Acquisition	Sweep uplink, don't wait for telemetry	seconds	10/12/00
FE 4	Primary command workstation failure	Command from backup workstation	1 minute	10/12/00
FE 4	Autonomous data rate change from 4mb to 10k	No action required	immediate	10/12/00
FE 4	Autonomous data rate change from 10k to 4mb	No action required	immediate	10/12/00



# TIMED

*Thermosphere • Ionosphere • Mesosphere • Energetics and Dynamics  
Flight Operations Review*

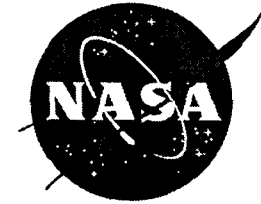

## Ground Station Contingencies (2 of 2)

<b>Problem</b>	<b>Planned Solution</b>	<b>Time to Implement</b>	<b>Procedure Tested</b>
RF equipment not setup properly for pass	Re-issue equipment configuration commands	1 minute	week of Oct 23
Bit Sync Failure	Swap in spare bit sync	30 minutes*	
Receiver Failure	Swap in spare receiver	30 minutes*	
Failure in uplink chain	Switch to backup uplink chain	5 minutes	Planned in Dec 00
Power amp failure	Use relay command to switch to spare power amp	5 minutes	Planned in Dec 00
Failure in cable feed from station to antenna	Change both ends to use spare cable	2 hours*	
Ground Station out of service	Schedule contacts using USN		

\*Requires Ground Station maintenance personnel.  
TIMED plan calls for support only during normal working hours.



# ***TIMED***

*Thermosphere • Ionosphere • Mesosphere • Energetics and Dynamics  
Flight Operations Review*

---

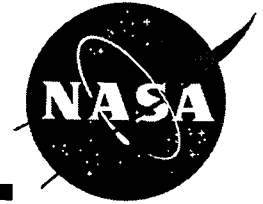

## Documentation Status

William P. Knopf  
JHU/APL  
(443) 778-6416  
[william.knopf@jhuapl.edu](mailto:william.knopf@jhuapl.edu)



# TIMED

*Thermosphere • Ionosphere • Mesosphere • Energetics and Dynamics  
Flight Operations Review*

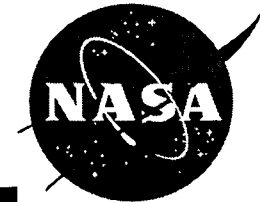

## MOC Document Status

Document	Status	Completion Date	Comments
Operations Handbook	50% final 50% draft	12/15/2000	Individual procedures have been signed off
Spacecraft Contingency Procedures	33% final 33% draft 33% in dev	12/15/2000	
Ground System Contingency Procedures	In process	12/31/2000	
Performance Assessment Guide	Complete	10/2000	
Autonomy Rules Handbook	Draft in use 9/2000	11/30/2000	Pending completion of response to rules section
Configuration Management Plan	Document in draft	11/15/2000	Formal documentation of CM design presented at MOR #2



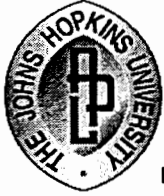

# TIMED

*Thermosphere • Ionosphere • Mesosphere • Energetics and Dynamics  
Flight Operations Review*

---



## ICD Status

- MOC to APL Satellite Control Facility
  - Draft in MOT review
  - Scheduled completion date: 12/15/2000
- TIMED Spacecraft to USN Commercial Ground Network
  - TIMED #7363-9389
  - Draft distributed March 2000
  - Final reviewed copy distributed for signature
- USN Commercial Ground Network to TIMED MOC
  - USN #143, Rev. D, July 6, 2000
  - Signatures pending 11/2000 testing



# TIMED

*Thermosphere • Ionosphere • Mesosphere • Energetics and Dynamics  
Flight Operations Review*

---



## Database Status

- Command and telemetry database mature
  - Subset to be defined as Mission Operations Command & Telemetry Database
    - Removes GNS and G&C test telemetry
  - Definition of command and telemetry now limited to MOT
    - Subsystem team access removed
  - Phase 1 Configuration Control (MOT, SBET) ended 6/2000
  - Phase 2 Configuration Control (MOT) in effect
  - Phase 3 Configuration Control (CCB): 11/30/2000



# ***TIMED***

*Thermosphere • Ionosphere • Mesosphere • Energetics and Dynamics*

*Flight Operations Review*

---



## Procedure Status

- Operations planning was successfully performed by all MOT personnel using documented planning procedures during the most recent 96 hour test
- Spacecraft contacts were successfully conducted by all MOT personnel using documented contact procedures during the most recent 96 hour test

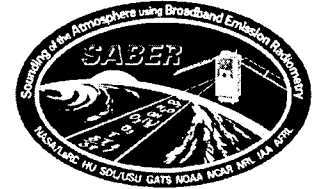

---

# SABER

## Payload Operations Control (POC) Review

Timed Mission Operations (MOPS) Review  
November 8, 2000

Richard Grube  
GATS, Inc  
[r.c.grube@gats-inc.com](mailto:r.c.grube@gats-inc.com)



RCG-1



## POC Hardware Status



### Production Payload Operations Control Computers

- Each POC computer can perform all POC functions alone but 2 are used at each control site for separation of commanding and telemetry display functions as well as immediate backup in case of a single computer failure.
- 2 FlightPOC computers reside at NASA LaRC.
- 2 TestPOC computers will reside at APL.
- 2 out of 4 production computers have been acquired, the 2 remaining computers will be purchased 4 months prior to launch.





## POC Hardware Status

---

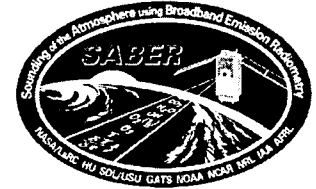

### Laptop Computer

- Provides for POC Commanding and Telemetry display capability anywhere via phone line dial-up.
- Can be used as a tertiary backup in case of any POC computer failure.

### Mission Operations beeper

- Planned acquisition 4 months prior to launch.
- Beeper system design and operation has SAGE III project heritage.





# POC Physical Layout (computers)

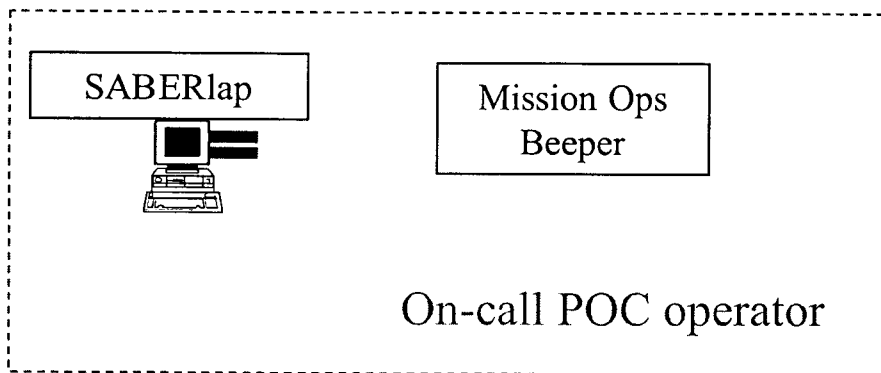
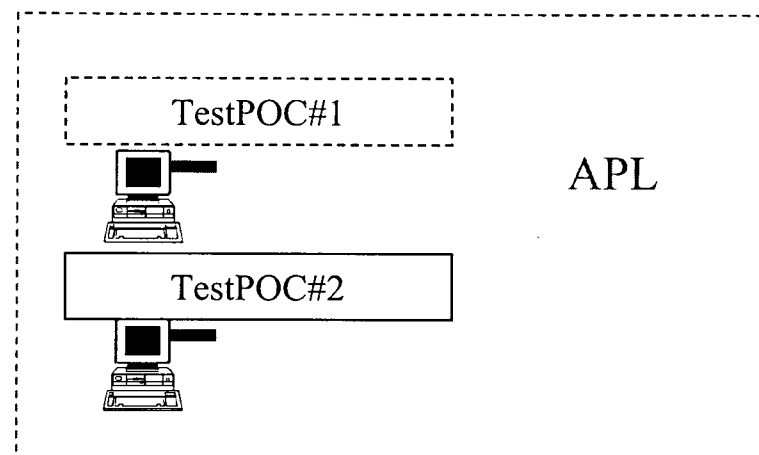
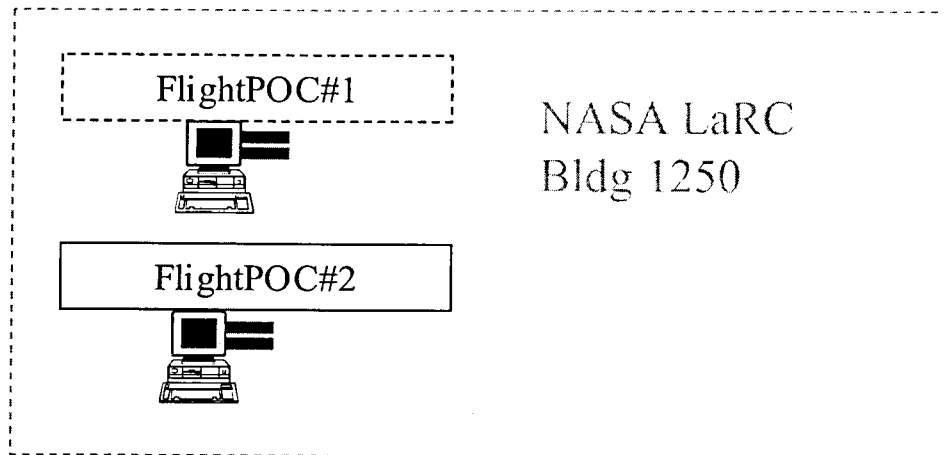

## Legend

- Internet/Intranet connection
- Modem connection





## POC Software Status

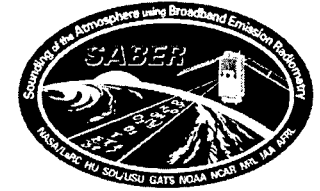

- **Replay - Telemetry display software**
  - Software is launch ready. Version 3.7.0 installed on 30 June 2000
    - Displays telemetry from both real time network sources and file playback.
    - Performs limit checking and generates alarm log, ad hoc housekeeping logs.
  
- **Commanding - SABER command generation software**
  - Software is launch ready. Version 3.0.1 installed on 23 August 2000
    - Generates, encrypts and FTP's SABER command message files.
    - Password checks performed for restricted commands.
    - Generates command history log.
  
- **Quicklook - Near real time Health Monitoring**
  - Software is in development and testing stage, delivery scheduled early November 2000 .
    - Performs limit checking and generates alarm log and beeper signal.







## POC Software Status



- Trending and Health Monitoring - Telemetry analysis software
  - Software is in development and testing stage, delivery scheduled late October 2000.
    - Daily report generator portion is currently being updated for alarm log generation and engineering calibration conversions.
    - Plotting tool requires minor modifications for production version.
- Mission Operations beeper - SABER limit reached warning to On-call POC operator.
  - Software is in development and testing stage, delivery scheduled for late October 2000.
    - Beeper function is being integrated into alarm log functions in both Replay and Trending and Health Monitoring Software.
    - Testing will be accomplished via use of the SAGE III beeper until the SABER beeper is purchased.





# System Overview of SABER POC

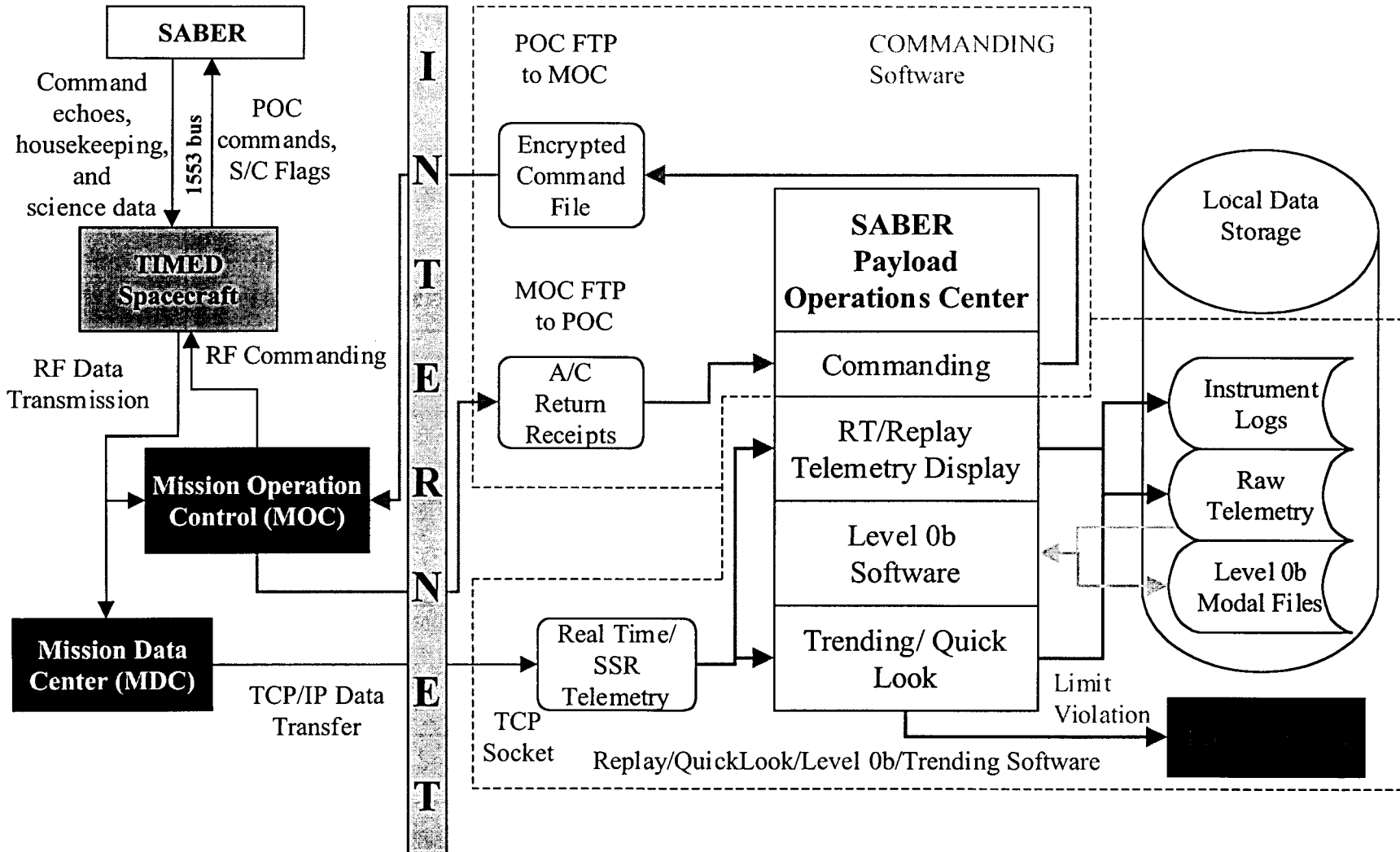



# SABER POC Commanding diagram

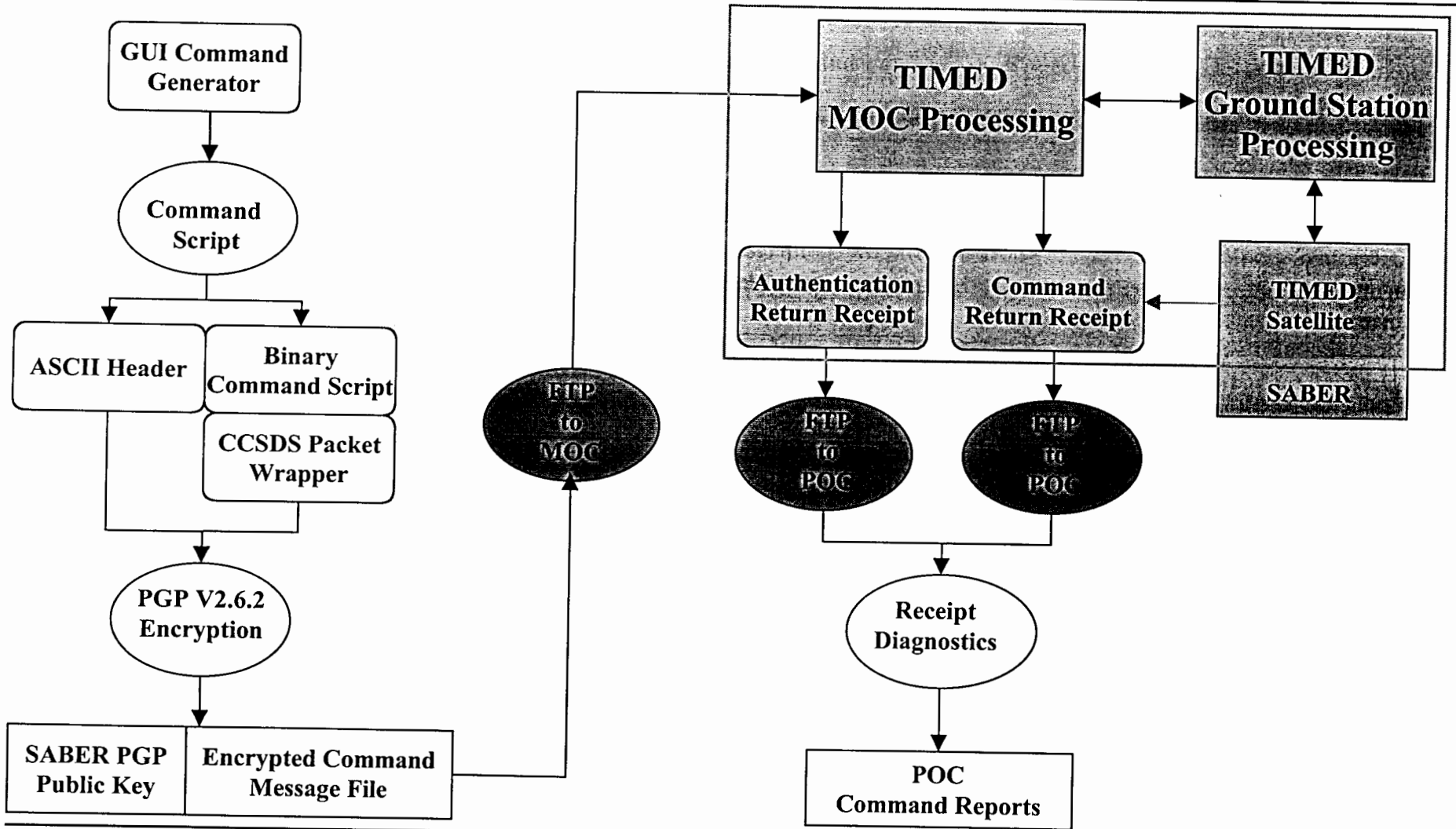
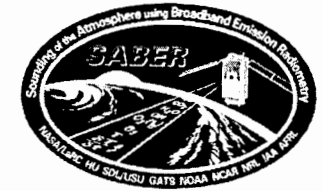



# SABER POC Replay diagram

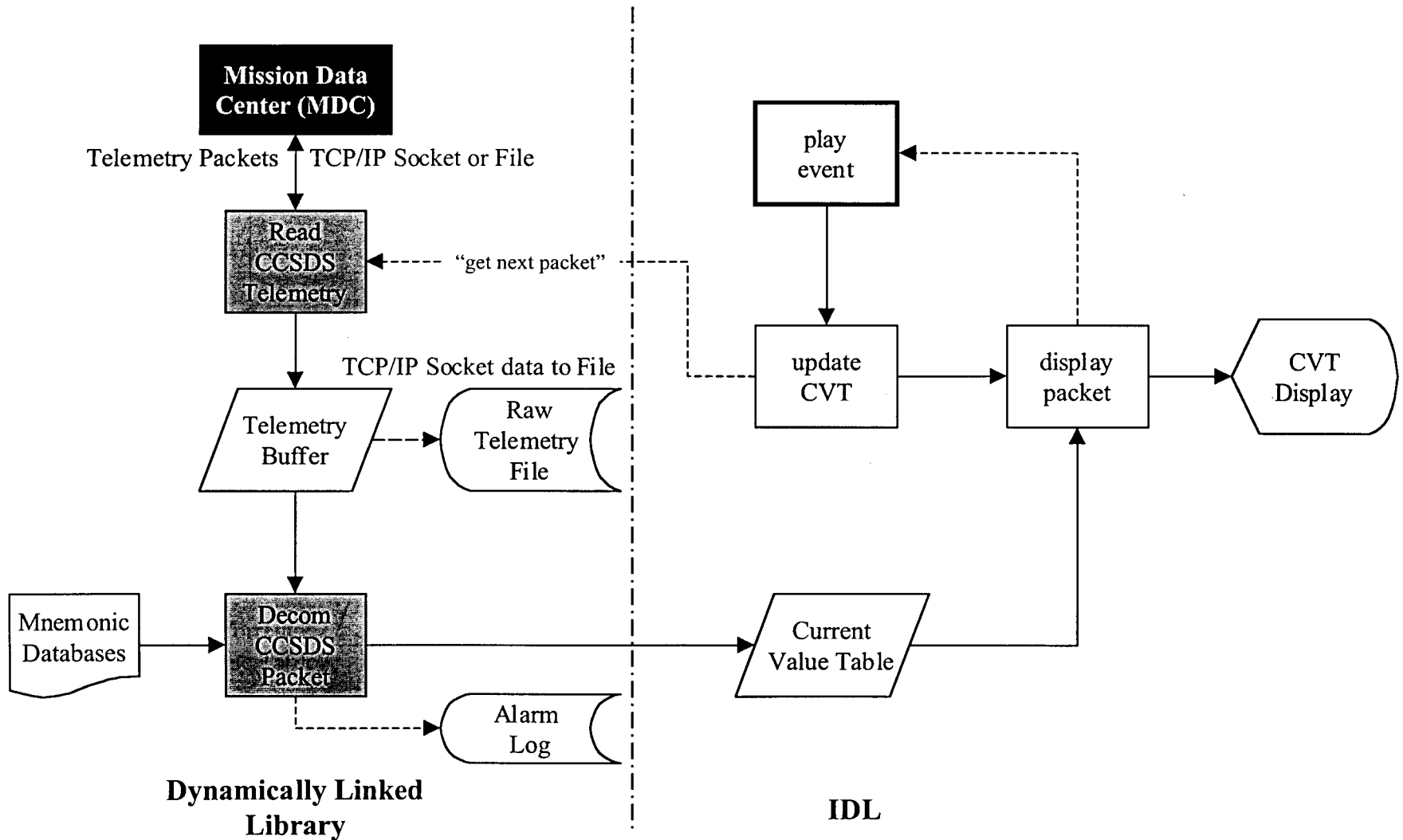
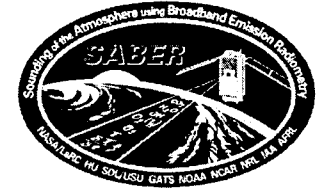



# SABER POC Quicklook Diagram

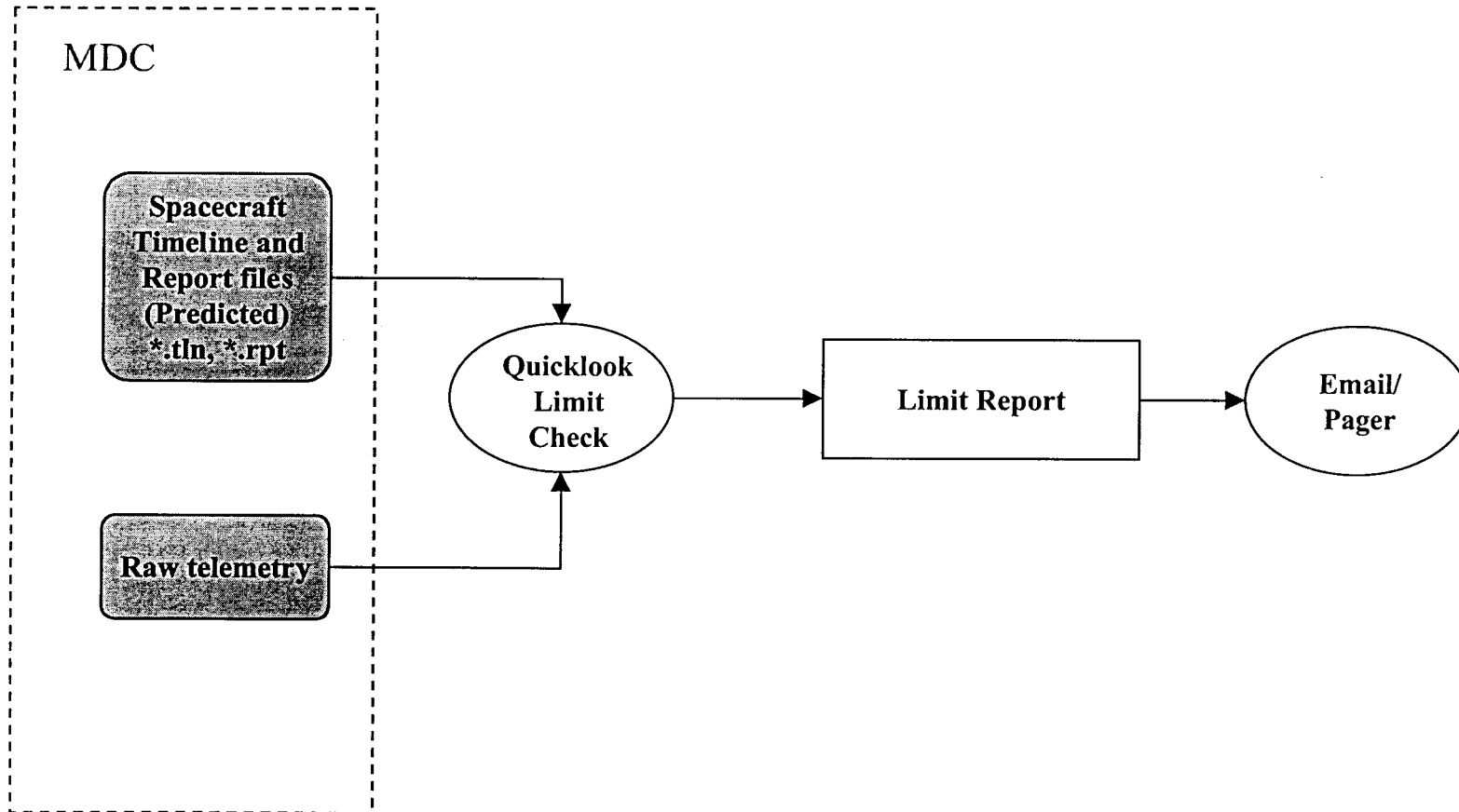
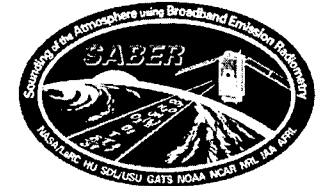



# SABER POC Trending and Health Monitoring Diagram

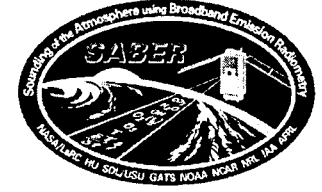

MDC

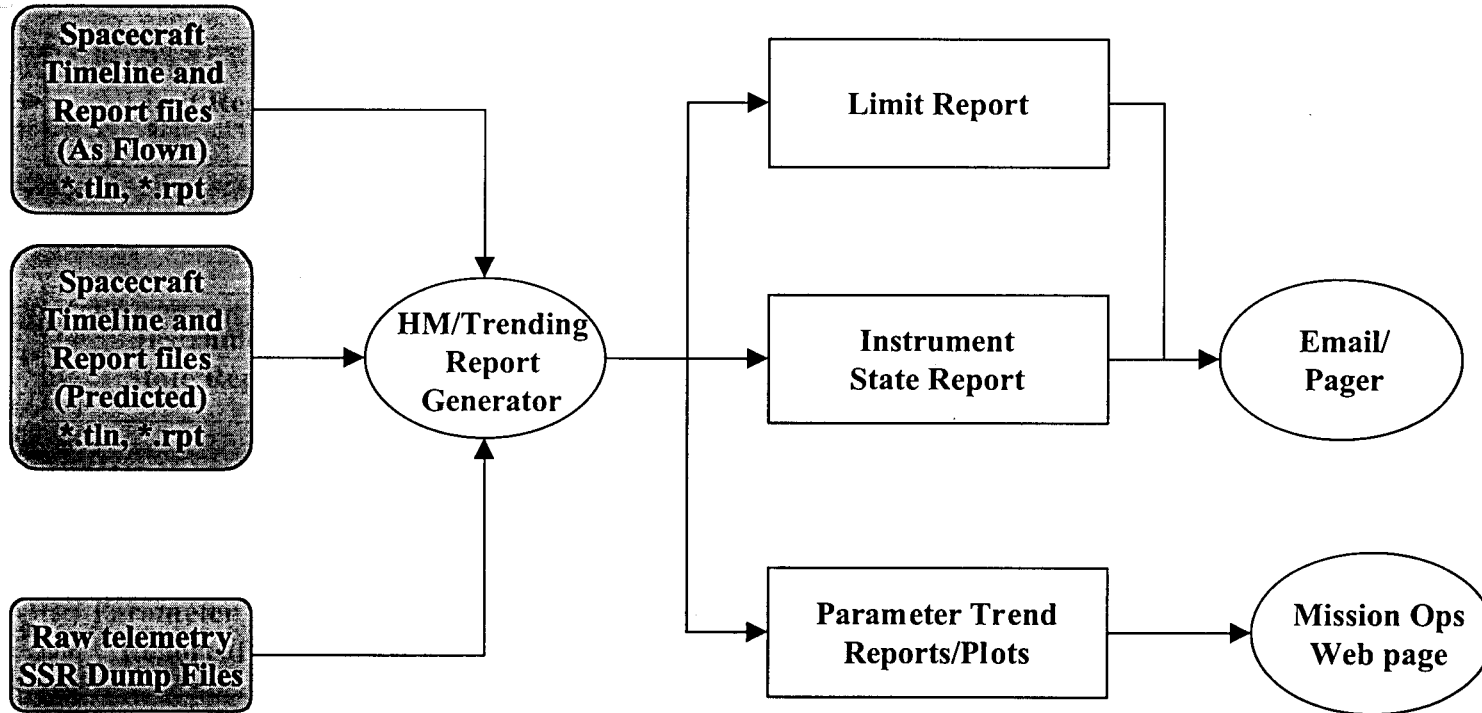



# SABER POC Level 0b diagram

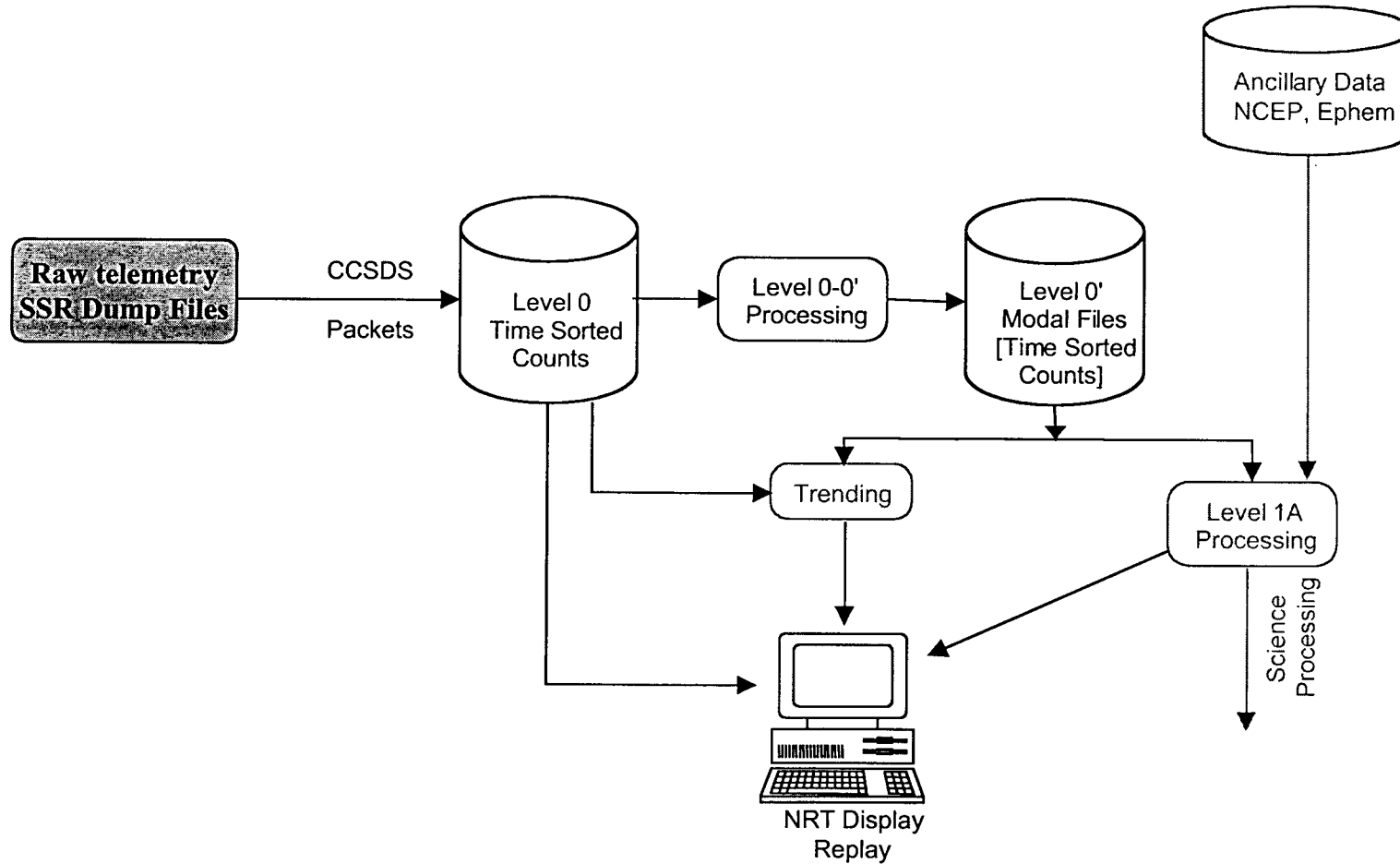
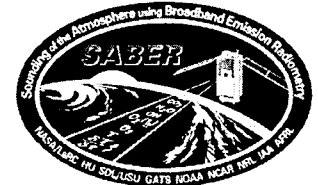

### Nominal SABER commissioning sequence (for February or March 2001 launch date)

<b>Launch</b> SABER survival htrs on at launch, verified on w/in 1 hr. after separation.	L+1 <b>Turn SABER pwr grp 1 &amp; OP htrs ON aliveness test</b>	L+2 Space Craft Bus Activation & Verification	L+3 Space Craft Bus Activation & Verification	L+4 Space Craft Bus Activation & Verification	L+5 Space Craft Bus Activation & Verification	L+6 Space Craft Bus Activation & Verification
L+7 Space Craft Bus Activation & Verification	L+8 Space Craft Bus Activation & Verification	L+9 Space Craft Bus Activation & Verification	L+10 Space Craft Bus Activation & Verification	L+11 Space Craft Bus Activation & Verification	L+12 Space Craft Bus Activation & Verification	L+13 Bus Activation & Verification  <b>SABER Memory Dump</b>
L+14 TIDI cover release via pyros  SABER Functional test w/o cooler	L+15  TIDI, GUVI testing	L+16 <b>Release SABER Baffle Cover (off nominal pointing)</b>	L+17  Outgas w/o cover	L+18 <b>Test and Turn SABER Cooler ON</b>	L+19  Allow SABER Cooler to thermally stabilize	L+20  Begin science ops
L+21  Normal science ops	L+22  Normal science ops	L+23  Normal science ops	L+24  Normal science ops	L+25  Normal science ops	L+26  Normal science ops	L+27  Normal science ops
L+28  Normal science ops Prep for off-axis	L+29  S/C Roll #1 Off-axis test (off nominal pointing)	L+30 <b>Return to Normal science ops Prep for off-axis</b>	L+31  S/C Roll #2 Off-axis test (off nominal pointing)	L+32 <b>Return to Normal science ops</b>	L+33  Normal science ops Prep for off-axis	L+34  S/C Roll #3 Off-axis test (off nominal pointing)
L+35  Return to Normal science ops	L+36  Normal science ops	L+37  Normal science ops	L+38  Normal science ops	L+39  Normal science ops	L+40  Normal science ops	L+41  Normal science ops

 = real time ops, command uploads occur at least 1 hour prior to event except for initial turn on, cover release, cooler turn on, and prep for off-axis.





## POC Early Ops Routine

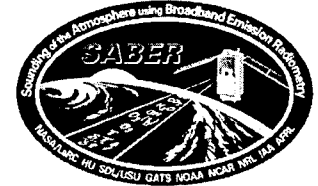

### **Memory Dump L+13**

- Dump contents of PROM and EEPROM memory to SSR.

### **Functional Test with out cooler L+14**

- Check out all SABER systems except for cooler. (Cooler not checked out for contamination reasons.)

### **Cover Release L+16**

- Release SABER Baffle Cover.

### **Cooler Functional test and Turn on ( 2 separate contacts) L+18**

- Turn on cooler after 1 day outgas period from cover release and test. After test, cooler is commanded to run through stabilize routine and normal science operations commence upon stabilization.

### **Off-Axis Roll Maneuvers (3 rolls) L+ 29,31,34**

- Three Off-Axis rolls performed to characterize off-axis light scatter affect. Operational limit of 1 degree between beta angle and roll angle for angles -0.4 through +17 and 2 degrees for +25 due to space craft overshoot . Note: Schedule dates may change due to beta angle.





## Personnel Location and Staffing (Early and Normal OPS)

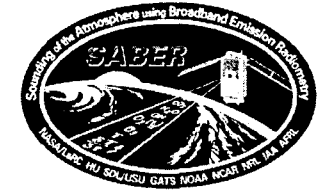

---

### Location of instrument/science team during real time/ early ops

- Flight POC - LaRC - Science team
- Test POC - APL - Instrument team, Science team reps., PI

### Location of instrument/science team during normal ops

- Flight POC - LaRC - Instrument team
  - PI and Science team members will meet at LaRC to perform early analysis of data in case of a limit violation.
- Test POC - APL - None

### Instrument Team Staffing early ops

- 2 POC operators - 5 days a week, 8hrs/day.
- Instrument Manager - 5 days a week, 8hrs/day.

### Instrument Team Staffing normal ops

- 1 POC operator - 5 days a week, 8am-5pm.
  - Work hours will shift for Contingency actions. Operator will also have SABER Laptop and Beeper for non-work hours - on-call status.
- Instrument Manager - 5 days a week, 8am-5pm.





# Overview of POC Nominal Routine (Diagram)

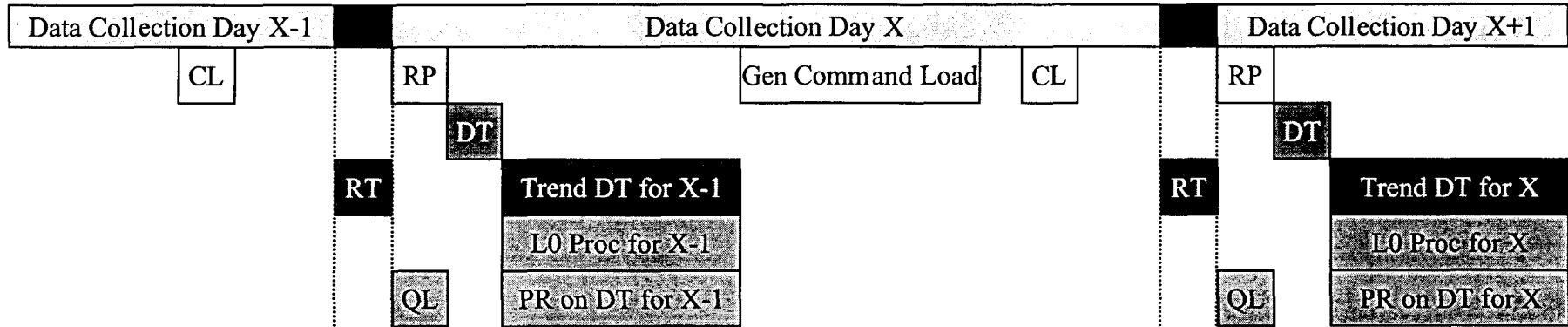
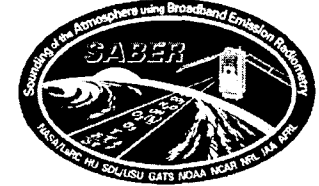

CL - Command Load delivered 4 hours prior to contact  
 RT - Real Time TLM during contact  
 RP - Command Receipt Processing following contact  
 QL - Quick Look Reports following contact  
 DT - Download SSR Dump TLM 1 hour after contact  
 L0 Proc - SSR Dump is processed by level0b software and sent to science data system  
 PR - Performance Reports processing commences after Dump completion





## Overview of POC Nominal Routine

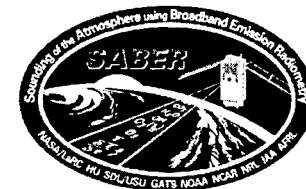

### Decoupled Operations

- SABER nominally operates independently of GUVI, SEE, TIDI and the TIMED Spacecraft.
- Only two currently planned SABER events require coordination with GUVI, SEE, TIDI and the TIMED Spacecraft.
  - Cover Release
  - Off-Axis Maneuver for scatter signal calibration

### Commanding Nominal Routine

- Commanding will normally be done 5 days a week during normal business hours 8am to 5pm.
- Minimal commanding required due to SABER state machine design.
- Nominal on-orbit commanding is expected to be weekly offset changes to compensate for orbit induced temperature changes.
- Command delivery and processing is checked via procedure.





## Overview of POC Nominal Routine (continued)

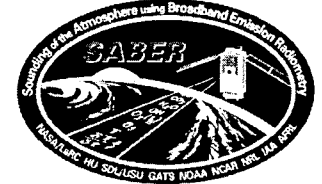

---

### Nominal Operational Trending and Health Monitoring

Two functions are used for this:

- Quicklook - checks for continuous alarm condition.
  - Automatic check of Real Time Telemetry for limit violations is done during every contact.
  - Limit violation triggers an email/ pager notification. No limit violation sends a nominal performance email only.
  
- Trending and Health Monitoring - checks for intermittent alarm.
  - Automatic check of Solid State Recorder (SSR) Telemetry dump for limit violations and performance trends. Performed when dump is available, an hour after contact.
  - Limit violation triggers an email/ pager notification. No limit violation sends a nominal performance email only.





## Contingency Plans (Automated)



### Automatic Reaction by TIMED

- SABER main power group power limit exceeded or OP heater power limit exceeded - SABER shut down and power removed from OP heaters and SABER.
- SABER Survival heater power limit exceed - SABER Survival heaters powered off and rule to turn them back on is disabled.
- SABER heartbeat failure - SABER shut down ( multiple restart option tested but not enabled).

### Automatic Reaction by SABER

- Cooler Overstroke condition - cooler shutdown.
- Yaw maneuver - SABER sent to safe mode until Yaw completion signaled via removal of Yaw flag. SABER returns to mode interrupted by Yaw.
- SABER Powerdown Warning flag - SABER enters safe mode and will not respond to any other commands until power cycled.





# Contingency Plans (Procedural)

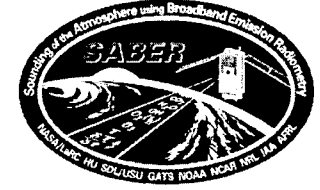

## On-orbit

General parameter limit exceeded procedures- (specific procedures in internal project review).

- Yellow limit violation
  - Instrument team review and analysis of affected parameter.
  - If possible, the rate of change will be approximated to determine the next contact where possible red limit action will be required.
  - PI, Science team, Spacecraft team notified.
  - Appropriate follow up actions performed as dictated by analysis and approved by PI and Instrument team management.
- Red limit violation
  - Send SAFE command to SABER to shutdown SABER and power off all but the main power group.
  - Instrument team, PI, and Science team review and analysis of affected parameter.
  - Appropriate follow up actions performed as dictated by analysis and approved by PI and Instrument team management.





## Contingency Plans (Procedural)

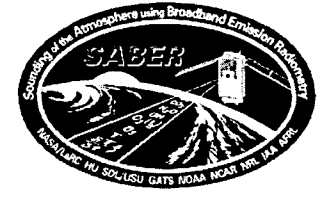

### On-orbit (cont.)

#### Specific parameter limit exceeded response procedure (example)

- TFO2VG1 (Focal Plane Array) yellow temperature violation
  - Instrument and Science team review and analysis of cause of temperature violation.
  - PI notified
  - Adjustment of cooler setpoint temperature to maintain Focal Plane Array at desired temperature will be performed as dictated by analysis and approved by PI and Instrument team management.

#### Loss of internet communications

- Switch to direct dial-up modem communications.

### Ground

#### Loss of nitrogen purge (ground testing only)

SABER shutdown and removal of power via TIMED MOC.







# Telemetry Monitoring and Assessment



## Telemetry Monitoring

- Spacecraft and SABER telemetry packets will be requested at each contact.
  - Parameters monitored from Spacecraft Packets
    - SABER Current for Main power group, OP heaters, and Survival heaters.
    - Space Craft Main Bus voltage.
    - SABER 1 second status words.
    - Spacecraft to SABER Interface temperatures.
    - SABER OP heater, survival heater, and main power group status flags.
  - Parameters monitored from SABER packets
    - Temperatures, voltages, currents, detector signals, and status flags.

## Assessment

- Automatic limit check of parameters
  - Red, Yellow, or Green limit zone entry and exit is automatically recorded.
- Gaps in telemetry data are recorded in a log created from each SSR dump.





# Trending



---

## Trending

Parameters monitored and plotted.

All limit checked parameters.

- Calculated parameters such as temperature deltas and powers.
- Detector performance.

Update frequency

- Trending plots and reports are updated every SSR dump.

Report and Plot timeframe

- Daily, Monthly, and Yearly summaries will be generated.





# Alarm and Safing Parameters (operational)



## SABER Operational

(cooler on and scan mirror scanning)

Alarms occur for yellow high or low violations

Safing action is required for red high or low violations

Operational Voltage Limits					
Mnemonic	Description	Red Minimum (V)	Yellow Minimum (V)	Yellow Maximum (V)	Red Maximum (V)
V1+5	DC/DC #1 +5V		4	6	
V2+15	DC/DC #2 +15V		14	16	
V2-15	DC/DC #3 -15V		-16	-14	
V4+5	DC/DC #4 +5V		4	6	
V5+15	DC/DC #5 +15V		14	16	
V5-15	DC/DC #6 -15V		-16	-14	
V6+15	DC/DC #7 +15V		14	16	
V7+15	DC/DC #8 +15V		14	16	
V7-15	DC/DC #9 -15V		-16	-14	
V9+5	DC/DC #10 +5V		4	6	
V10+28	DC/DC #11 +28V		27	29	

Operational Temperature Limits					
Mnemonic	Description	Red Minimum (K)	Yellow Minimum (K)	Yellow Maximum (K)	Red Maximum (K)
TFO1VG1	FPA		70	80	
TFO1VG2	FPA		70	80	
TFO2VG1	FPA		70	80	
TFO2VG2	FPA		70	80	
TFO3	Top of Link		70	80	
TFO4	Top of Link		70	80	
TFO5	RF Cold Block		70	80	
TFO6	Bottom of Link		70	80	
TTO1	Optics Radiator-Top left		210	233	
TTO2	Op. Rad Near Wax Act.		210	233	
TTO3	Baffle-At aper top left		211	235	
TTO4	Scan housing at IFC		217	238	
TTO5	Baffle/Scan housing interface		215	237	
TTO6	Baffle wall near bearing right		217	238	
TTO7	Baffle wall near lower scan housing		219	238	
TTO8	Encoder mnt./ Radiator side		221	239	
TTO9	Encoder mnt./ IFC side		221	239	
TTO10	Fore optics S/C side		217	238	
TTO11	IFC #1		240	260	
TTO12	IFC #2		240	260	
TTO13	IFC #3		240	260	
TTO14	Re-imager near FPA		218	240	
TTO15	Chopper base right		217	238	
TTO16	Chopper base left		216	238	
TMO1	TRW Refrigerator		254	270	
TMO2	RF Mount Bottom of cone		245	265	
TMO3	Elec. Radiator at RF mnt base		244	264	
TMO4	Elec. Rad. At E-box (Not Working)		322	323	
TMO5	IEB TRW side		247	269	
TMO6	IEB Back		248	270	
TMO7	Elec. Rad at RFE box		241	263	
TMO8	RFE back		297	315	
TMO9	RFE near IEB and Elec. Rad.		294	311	
TCO1	Wax actuator top side		209	233	
TCO2	Wax Actuator cooler side		208	233	
TEO1	IEB Electronics		255	263	
TEO2	IEB Electronics		261	280	
BBMON	blackbody set voltage		240	260	
BBSETV	blackbody set temperature		240	260	
COOMT	Cooler Mount		237	320	
EBOX	Electronics Box		218	320	
ENMAS	Encoder/Motor Assembly		210	320	
IF1	Cooler Mount		218	320	
IF2	Electronics Box		218	320	
OPRAD	Op. Radiator		200	320	





# Alarm and Safeing Parameters (survival)



## SABER Survival

(OFF with only survival heater  
or ON with only main power group)

Alarms occur for yellow high or  
low violations

Safeing action is required for red  
high or low violations

Survival Voltage Limits					
Mnemonic	Description	Red Minimum (V)	Yellow Minimum (V)	Yellow Maximum (V)	Red Maximum (V)
V1+5	DC/DC #1 +5V		4	6	
V2+15	DC/DC #2 +15V		27	29	
V2-15	DC/DC #3 -15V		14	16	
V4+5	DC/DC #4 +5V		-16	-14	
V5+15	DC/DC #5 +15V		4	6	
V5-15	DC/DC #6 -15V		14	16	
V6+15	DC/DC #7 +15V		-16	-14	
V7+15	DC/DC #8 +15V		14	16	
V7-15	DC/DC #9 -15V		14	16	
V9+5	DC/DC #10 +5V		-16	-14	
V10+28	DC/DC #11 +28V		4	6	

Survival Temperature Limits					
Mnemonic	Description	Red Minimum (K)	Yellow Minimum (K)	Yellow Maximum (K)	Red Maximum (K)
TFO1VG1	FPA		70	320	
TFO1VG2	FPA		70	320	
TFO2VG1	FPA		70	320	
TFO2VG2	FPA		70	320	
TFO3	Top of Link		70	320	
TFO4	Top of Link		70	320	
TFO5	RF Cold Block		70	320	
TFO6	Bottom of Link		70	320	
TTO1	Optics Radiator-Top left		200	320	
TTO2	Op. Rad Near Wax Act.		200	320	
TTO3	Baffle-At aper top left		201	320	
TTO4	Scan housing at IFC		204	320	
TTO5	Baffle/Scan housing interface		205	320	
TTO6	Baffle wall near bearing right		205	320	
TTO7	Baffle wall near lower scan housing		205	320	
TTO8	Encoder mnt./ Radiator side		210	320	
TTO9	Encoder mnt./ IFC side		210	320	
TTO10	Fore optics S/C side		207	320	
TTO11	IFC #1		207	320	
TTO12	IFC #2		207	320	
TTO13	IFC #3		207	320	
TTO14	Re-imager near FPA		207	320	
TTO15	Chopper base right		207	320	
TTO16	Chopper base left		207	320	
TMO1	TRW Refrigerator		237	320	
TMO2	RF Mount Bottom of cone		227	320	
TMO3	Elec. Radiator at RF mnt base		226	320	
TMO4	Elec. Rad. At E-box (Not Working)		322	323	
TMO5	IEB TRW side		218	320	
TMO6	IEB Back		218	320	
TMO7	Elec. Rad at RFE box		218	320	
TMO8	RFE back		218	320	
TMO9	RFE near IEB and Elec. Rad.		218	320	
TCO1	Wax actuator top side		200	320	
TCO2	Wax Actuator cooler side		200	320	
TEO1	IEB Electronics		218	320	
TEO2	IEB Electronics		218	320	
OPRAD	Op. Radiator		200	320	
ENMAS	Encoder/Motor Assembly		210	320	
COOMT	Cooler Mount		237	320	
EBOX	Electronics Box		218	320	
IF1	Cooler Mount		218	320	
IF2	Electronics Box		218	320	
BBMON	blackbody set voltage		240	320	
BBSETV	blackbody set temperature		240	320	





## Alarm and Safeing Parameters

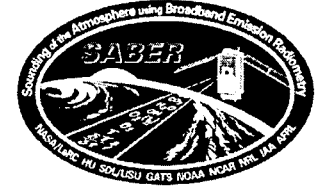

Current, power, voltage and some temperature limits are undergoing internal review based on data gathered during thermal vacuum testing.

### Safeing actions for Red Limit Temperatures

- Red High

- Turn off associated component and power group to lower temperature, ensure heaters are operating properly.

- Red Low

- Turn on associated component and power group to raise temperature ensure heaters are operating properly.





# Science Data System (SDS) Data Flow

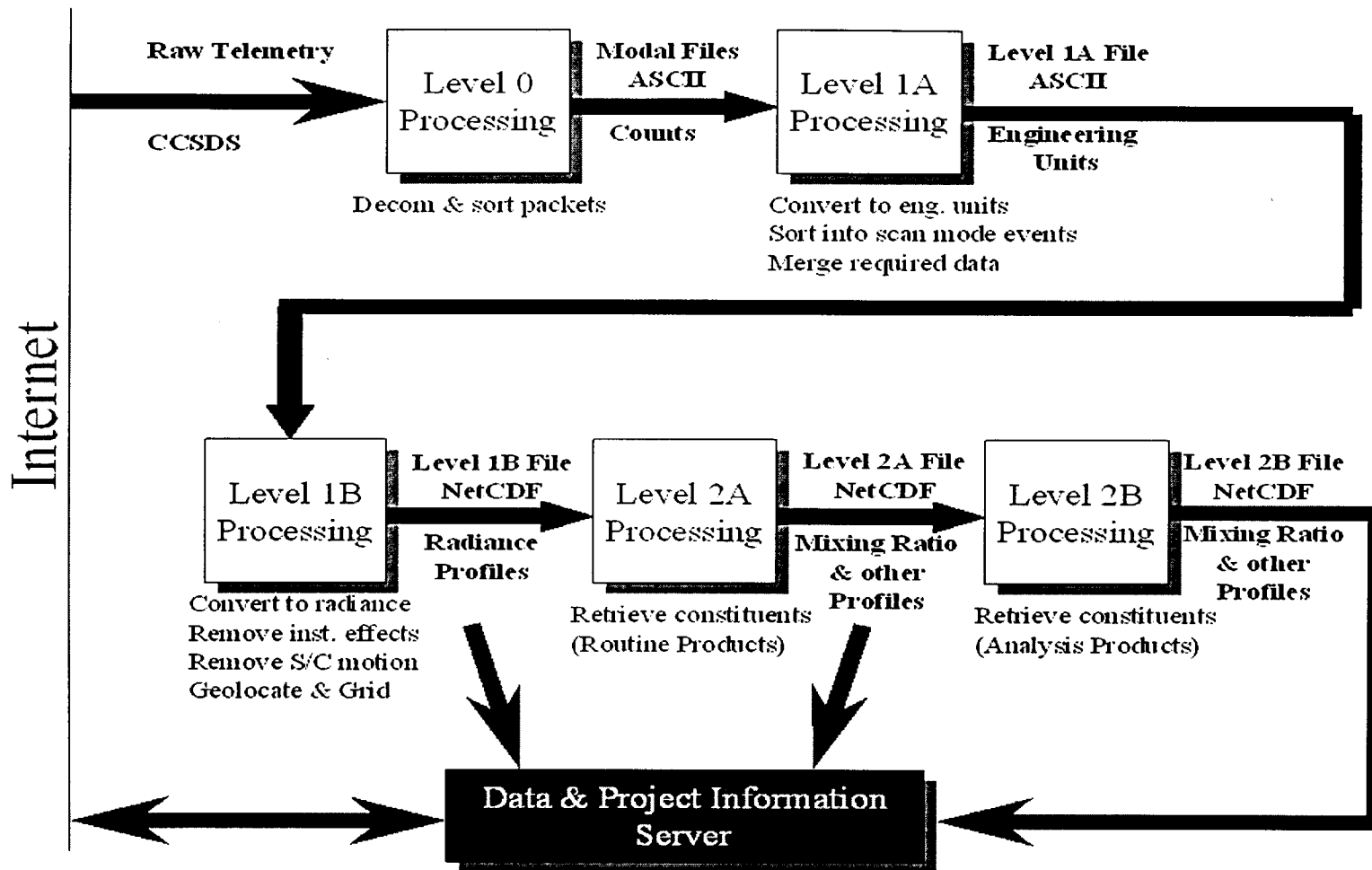
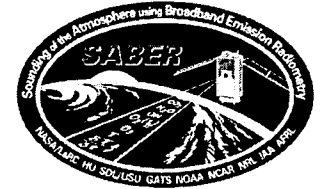



# DATA & Project Information Server (DPIS)

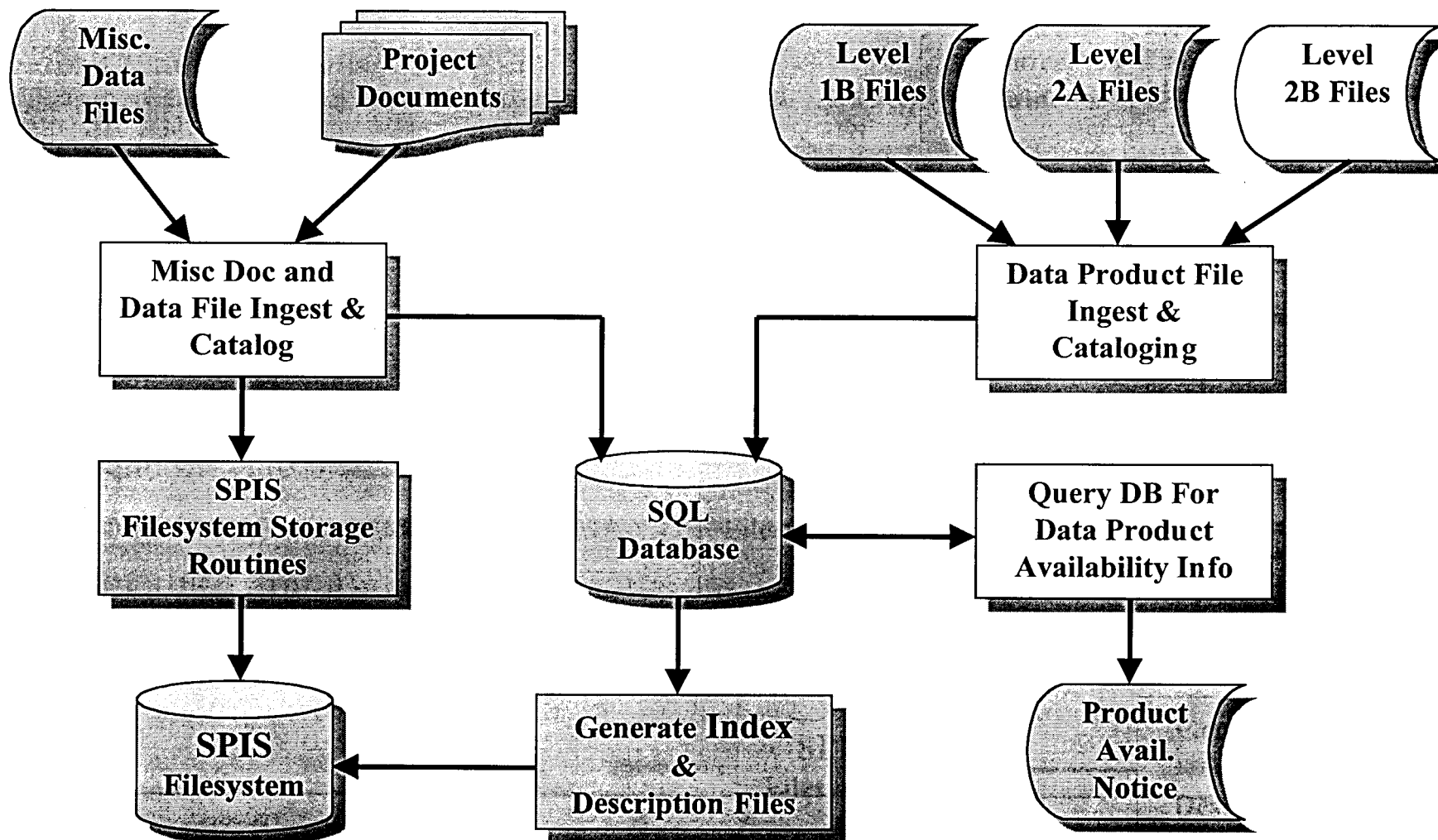
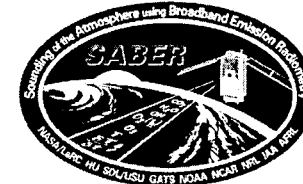

Memory Configurator



Search  Go

Memory CPU's Motherboards Hard Drives Portable Devices Video Cards Software Modems Laptop Peripherals Networking

CD/CDRW/DVD  
Corp./Gov't

Low Grade – Basic DRAM Quality based on low-end spot market- DRAM Brands: ACT, SMT, Jtec, PQI, KIC, NTK or similar CAS3 memory. Not Recommended for Athlon and Intel 810, 815, 820, 840 Chipsets. Not recommend for most name brand motherboards and system. One Year Warranty.

..... Mid Grade – Industry Standard fully qualified DRAM "Major Name Brands" DRAM: Vanguard, Nanya, Vitalic, Spectek, LD or Similar – CAS3 Latency. Recommended for Intel 810, 815, 820, 840 Chipsets. Life time warranty!

..... High Grade – Best Quality DRAMS on the SOJ market. DRAM Brands: Toshiba, Samsung, Hitachi, NEC, Hyandai, LGS, Micron Technology or Similar – CAS3 Latency. Recommended for Athlon and Intel 810, 815, 820, 840 Chipsets. Recommended for Asus, Abit, and FIC, or similar motherboards. Life Time Warranty

..... Elite CAS2 Grade – Best Quality and most stable DRAM on the SOJ market. Faster CAS2 Latency. Frequently used in overclocked systems and for applications that require the most stable hardware environments. DRAM brands: Micron Technology, Siemens/Infineon or similar CAS2 Latency. Recommended for Athlon and Intel 810, 815, 820, 840 Chipsets. Recommended for Windows NT and Server Applications. Recommended for High End Graphics, 3D rendering and Gaming. Recommended for Asus, Abit, and FIC, or similar motherboards. Life Time Warranty

<u>168 Pin 128MB Micron Technology Elite Grade</u>	128PC133E	\$164.00	
<u>168 Pin 128MB PC133 High Grade</u>	128PC133H	\$99.00	
<u>168 Pin 128 MB PC133 Low Grade "Limit One"</u>	128PC133L	\$56.00	
<u>168 Pin 128MB PC133 Mid Grade</u>	128PC133M	\$68.00	
<u>168 Pin 256MB ECC PC133 Mid Grade</u>	256ECCPC133M	\$279.00	
<u>168 Pin 256MB PC133 Low Grade</u>	256PC133L	\$130.00	
<u>168 Pin 256MB PC133 Mid Grade</u>	256PC133M	\$149.00	
<u>168 Pin 64 MB PC133 High Grade</u>	64PC133H	\$59.00	
<u>168 Pin 64 MB PC133 "Limit One"</u>	64PC133L	\$32.00	
<u>168 Pin 64MB PC133 Mid Grade</u>	64PC133M	\$43.00	



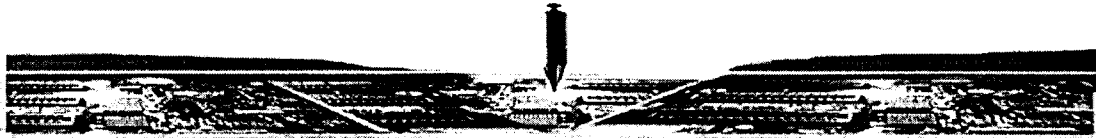

---

**Order Hotline: 1-800-964-5007**

[Memory](#) [CPUs](#) [Motherboards](#) [Hard Drives](#) [Portable Devices](#)  
[CD-ROM/DVD Drives](#) [Video Cards](#) [Software](#) [Miscellaneous](#) [Modems](#) [Laptops](#) [Peripherals](#) [Networking](#)  
[Privacy Policy](#) [Disclaimers](#) [Warranty & Returns](#) [RMA](#)

---

All trademarks™ and registered trademarks® are the property of their respective owners.  
Copyright © All original material, content, and images contained within are  
the property of Upgrade Planet.com™ and are subject to all applicable international and national copyright laws.

# TIMED SPACECRAFT MISSION OPERATIONS REVIEW

## *TIMED/SEE INSTRUMENT*

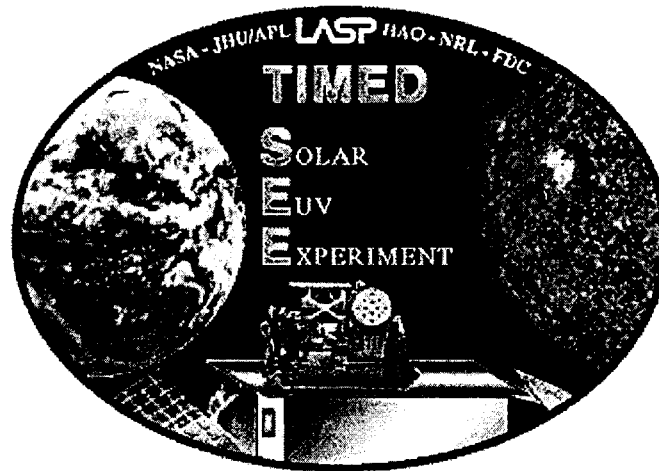

Gail Tate and Don Woodraska

November 8, 2000

# Flight Operations Review Outline

- ❑ TIMED/SEE Acronyms
- ❑ TIMED/SEE Operational Overview
- ❑ Real-Time Operations
- ❑ Engineering Data Processing
- ❑ Science Data Processing
- ❑ Planning/Scheduling
- ❑ Normal Operations
- ❑ Early Orbit Operations
- ❑ Monitoring and Instrument Safety
- ❑ Contingency Operations
- ❑ Security
- ❑ Miscellaneous

# TIMED/SEE Acronyms - 1

- CSTOL - Colorado System Test & Operations Language
- EGS - EUV Grating Spectrometer
- EUV - Extreme Ultraviolet
- FTP - File Transfer Protocol
- HK - Housekeeping
- HV - High Voltage
- IDL - Interactive Data Language
- OASIS-CC - Operations and Science Instrument Support - Command and Control
- OASIS-PS - Operations and Science Instrument Support - Planning and Scheduling
- ODC - Observation Description Command

## TIMED/SEE Acronyms - 2

- PBK - Playback
- RT - Real-Time
- SEE - Solar EUV Experiment
- SSPP - SEE Solar Pointing Platform
- S/C - Spacecraft
- TCAD - Telemetry, Check, Analysis, Display
- TCP/IP - Transmission Control Protocol/Internet Protocol
- TLM - Telemetry
- XPS - XUV Photometer System
- XUV - Soft X-Ray Ultraviolet

# OPERATIONAL OVERVIEW

# SEE Mission Operations Requirements -1

- SEE Uplink Operations:
  - Generate commands
  - Construct Command Message Files (CMF)
  - Encrypt and transmit CMFs to MOC
  - Confirm delivery of commands to MOC and Spacecraft
  - Confirm proper SEE command execution
  - Archive commands
  - Execute procedures to carry out planned activities

# SEE Mission Operations Requirements -2

- SEE Downlink Operations:
  - Retrieve RT and PBK data from MDC
  - Process S/C and SEE TLM packets
  - Monitor instrument health and safety
  - Archive data



# SEE Mission Operations Requirements -3

- SEE Data Processing Operations:
  - Monitor instrument health and safety
  - Process science data
  - Generate data products
  - Retrieve planning products from MDC
  - Plan and schedule SEE activities

# SEE POC Operational Concept

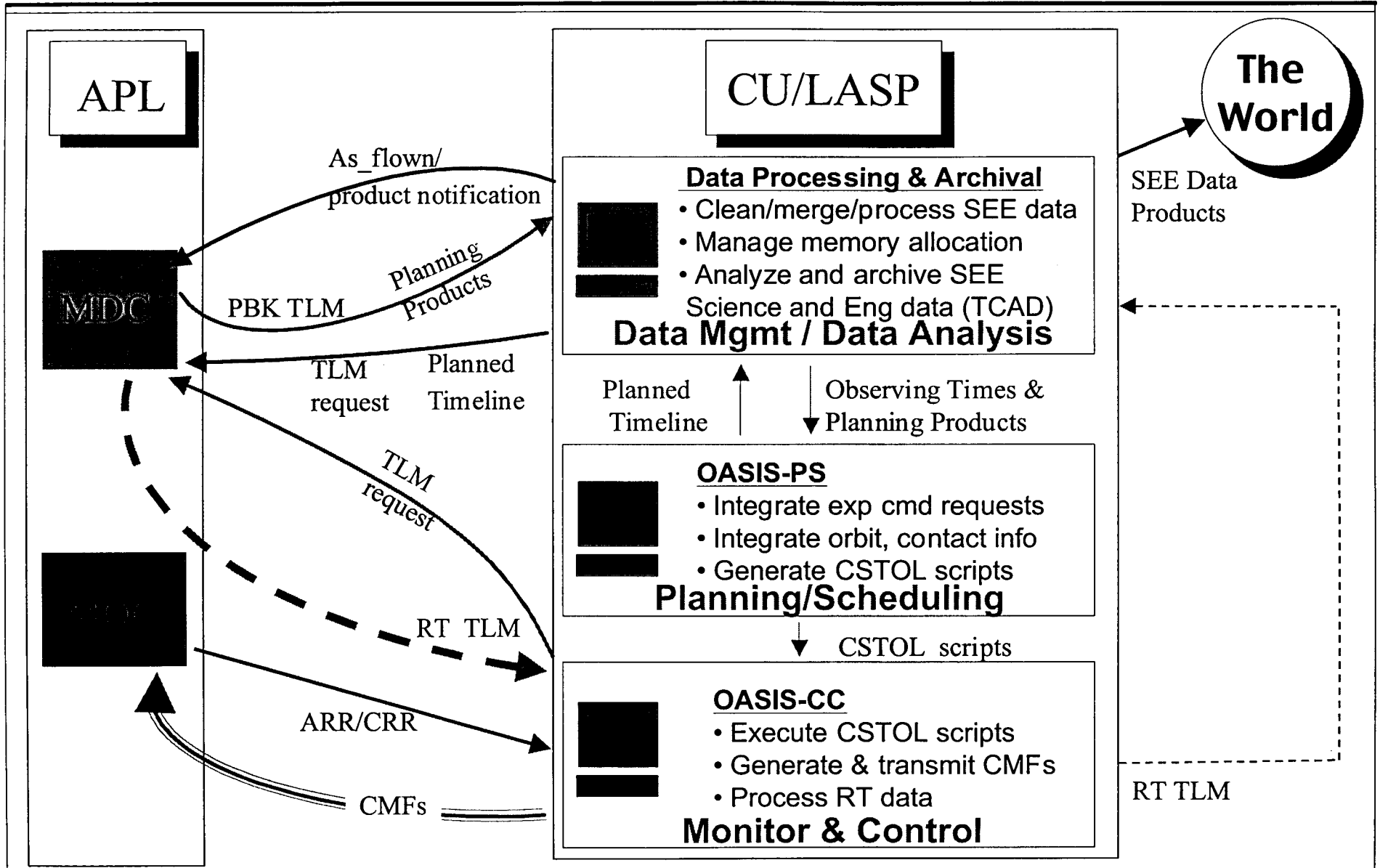

# SEE POC - MOC Interface

- SEE POC => MOC
  - Provide SEE commands: RT, delayed, microprocessor loads
  - Notification of command loads exceeding 2Kbytes
  - Voice communications during RT contacts
- MOC => SEE POC
  - Command receipt notification: ARR,CRR
  - Voice communications during RT contacts

# SEE POC-MDC Interface

- SEE POC => MDC
  - Telemetry service request commands
  - Planned timelines
  - As-flown & product notification files
- MDC => SEE POC
  - RT/PBK telemetry
  - Planning products

# SEE POC Hardware

## LASP

Sun Ultra  
Enterprise 450  
Engineering  
Processing  
TCAD

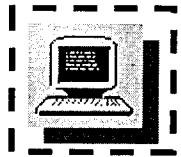

Science  
Team



Anonymous  
FTP Server

## SEE Flight POC

Sun Ultra 1  
OASIS-CC  
OASIS-PS

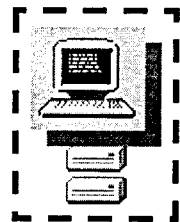
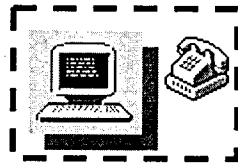

Sun Ultra 30  
IDL Science Data  
Processing & Archival

## APL

### SEE Test POC

Sun Ultra 10  
OASIS-CC

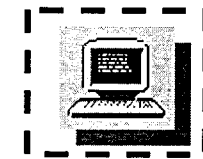

# TIMED/SEE Support Systems -1

- OASIS-CC (RT support)
  - Acquire SEE and S/C data
  - Generate and transmit commands
  - Confirm command receipt and execution
  - Monitor health and safety of SEE
- Data Acquisition (Batch Script)
  - Retrieve SEE and S/C data from the MDC
- Engineering Data Processing (TCAD)
  - Extract, state/limit check, and trend individual measurements from SEE HK & S/C packets

# TIMED/SEE Support Systems -2

- Science Data Processing (IDL)
  - Process SEE science data
  - Ingest planning products
  - Generate initial planned timeline and data products
  
- Planning and Scheduling (OASIS-PS)
  - Ingest planning products
  - Plan and schedule SEE instrument activities
  - Generate final planned timeline and CSTOL scripts

# REAL-TIME OPERATIONS



# TEST POC Data Flow Diagram

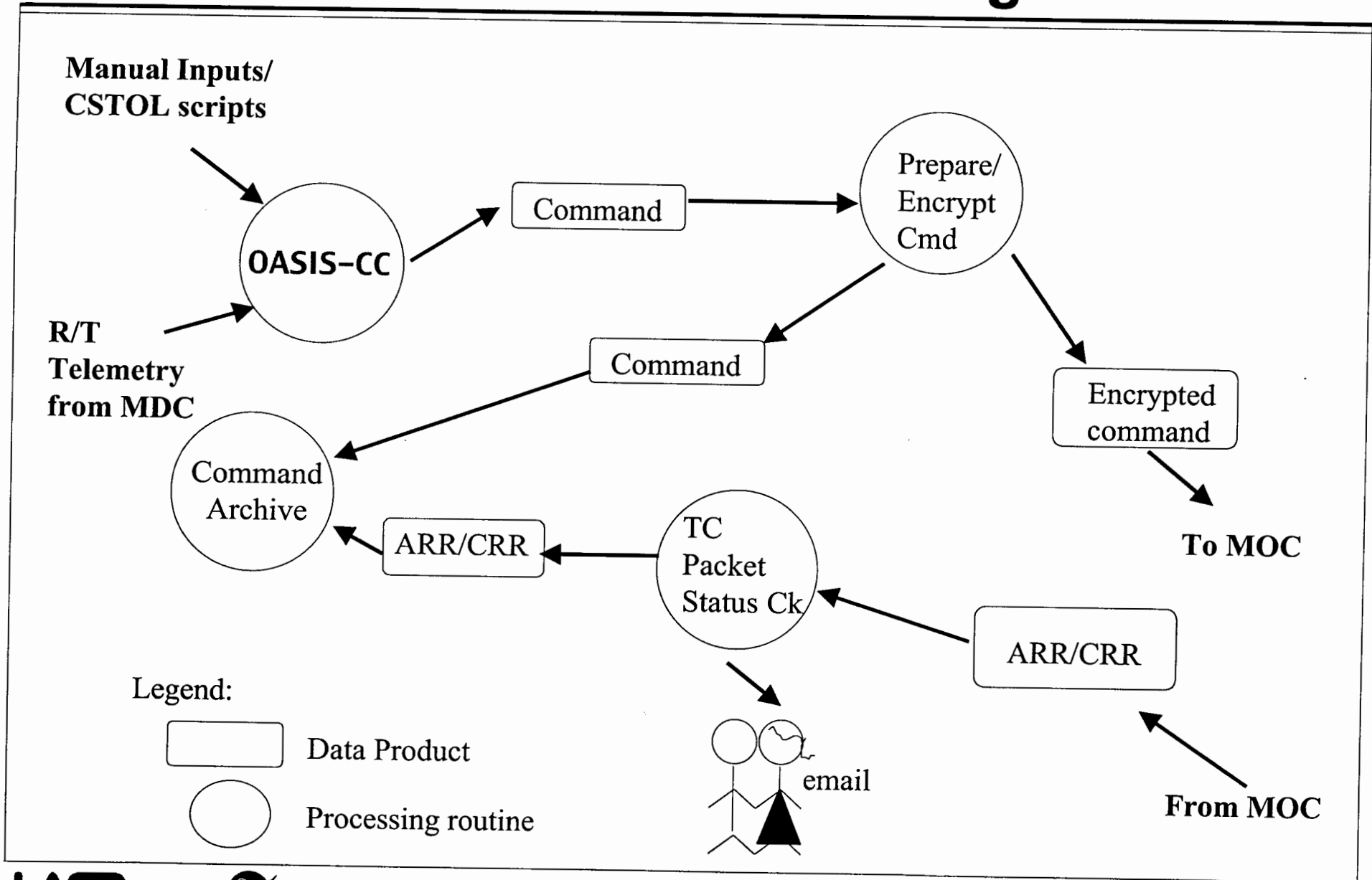

# **TIMED/SEE ENGINEERING DATA PROCESSING (TCAD)**

# Eng Data Processing Flow Diagram

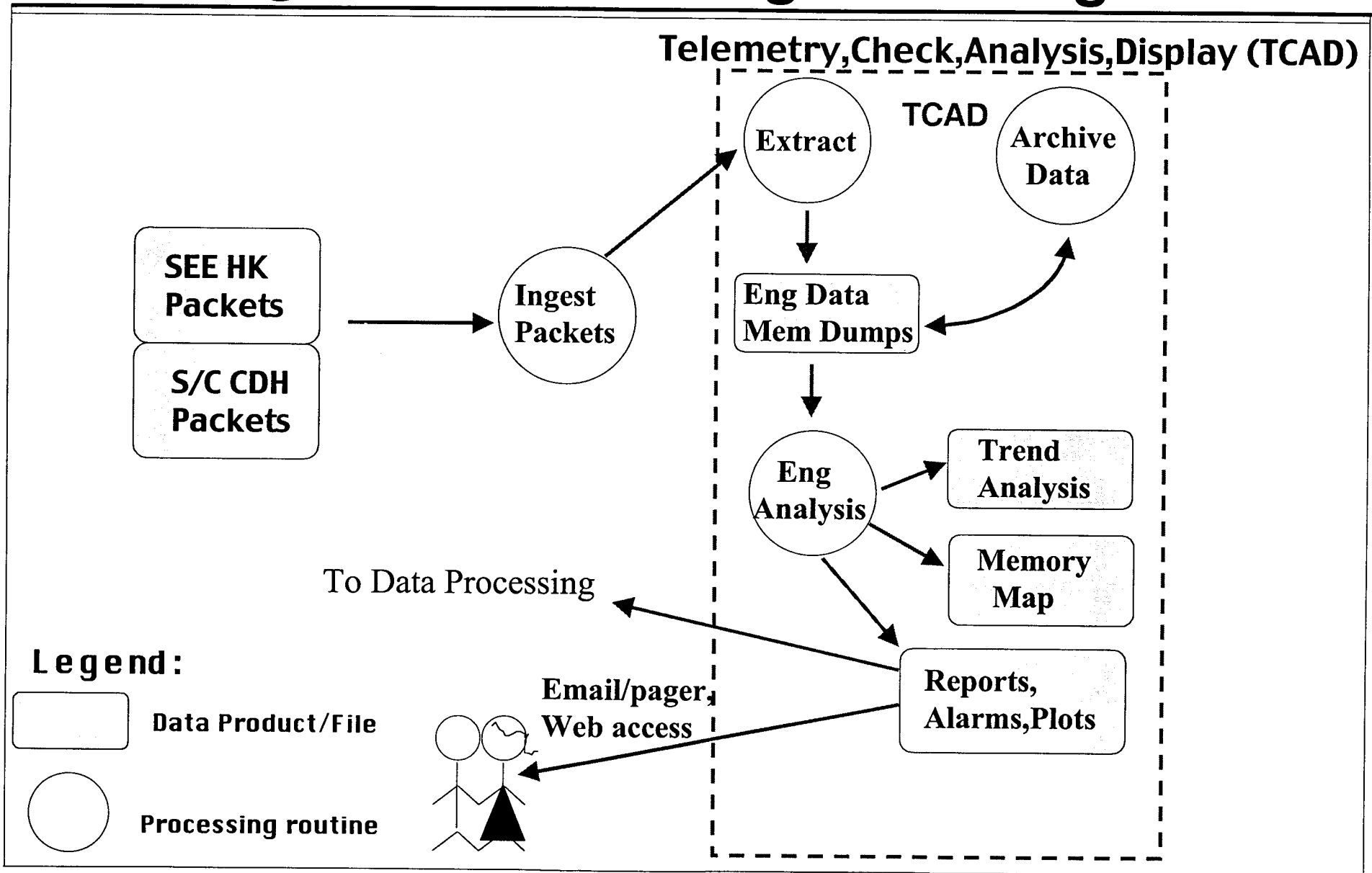

# SCIENCE DATA PROCESSING (IDL)

# Science Data Processing

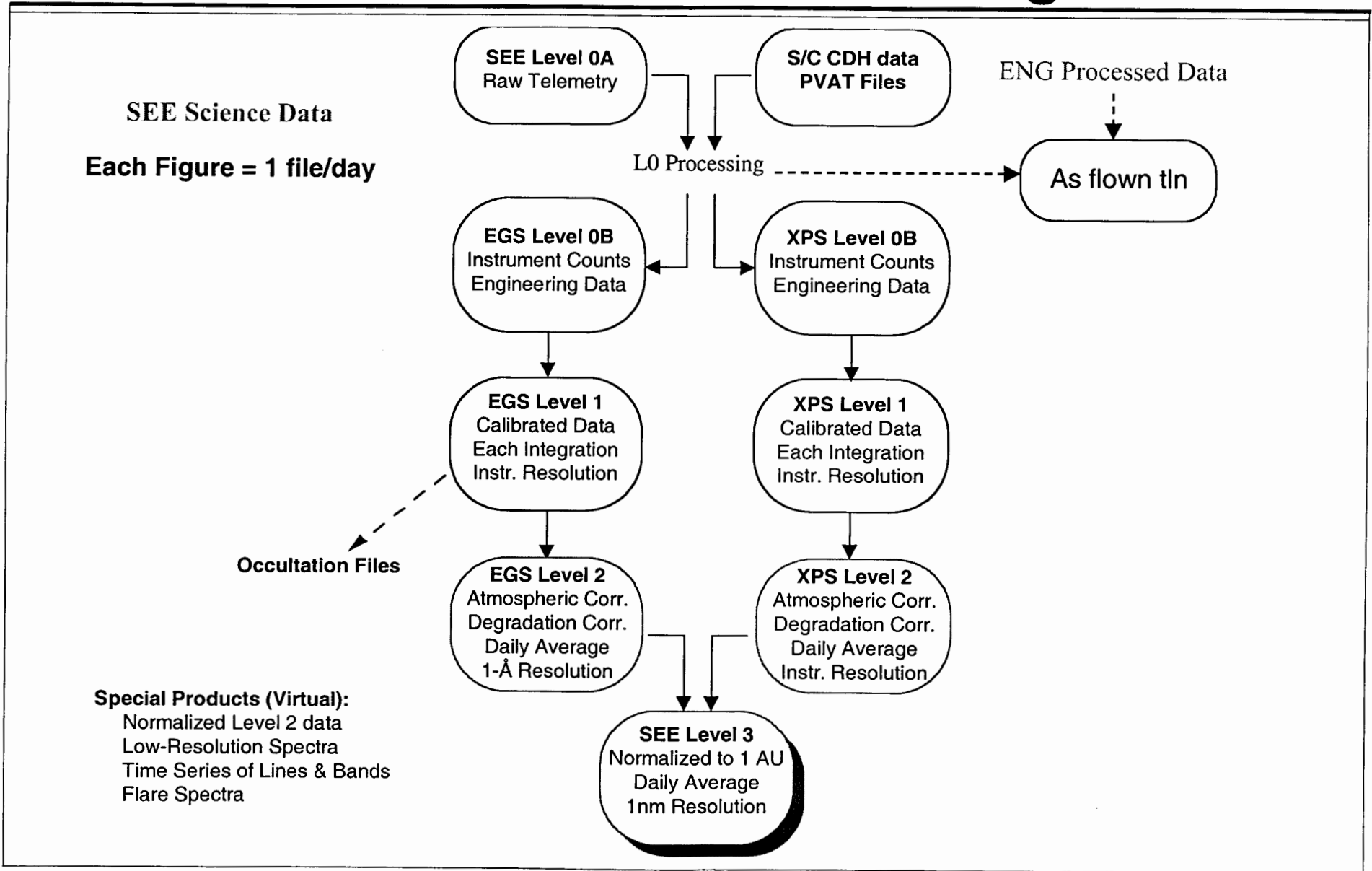

# PLANNING/SCHEDULING (OASIS-PS)

# OASIS-PS User Interface

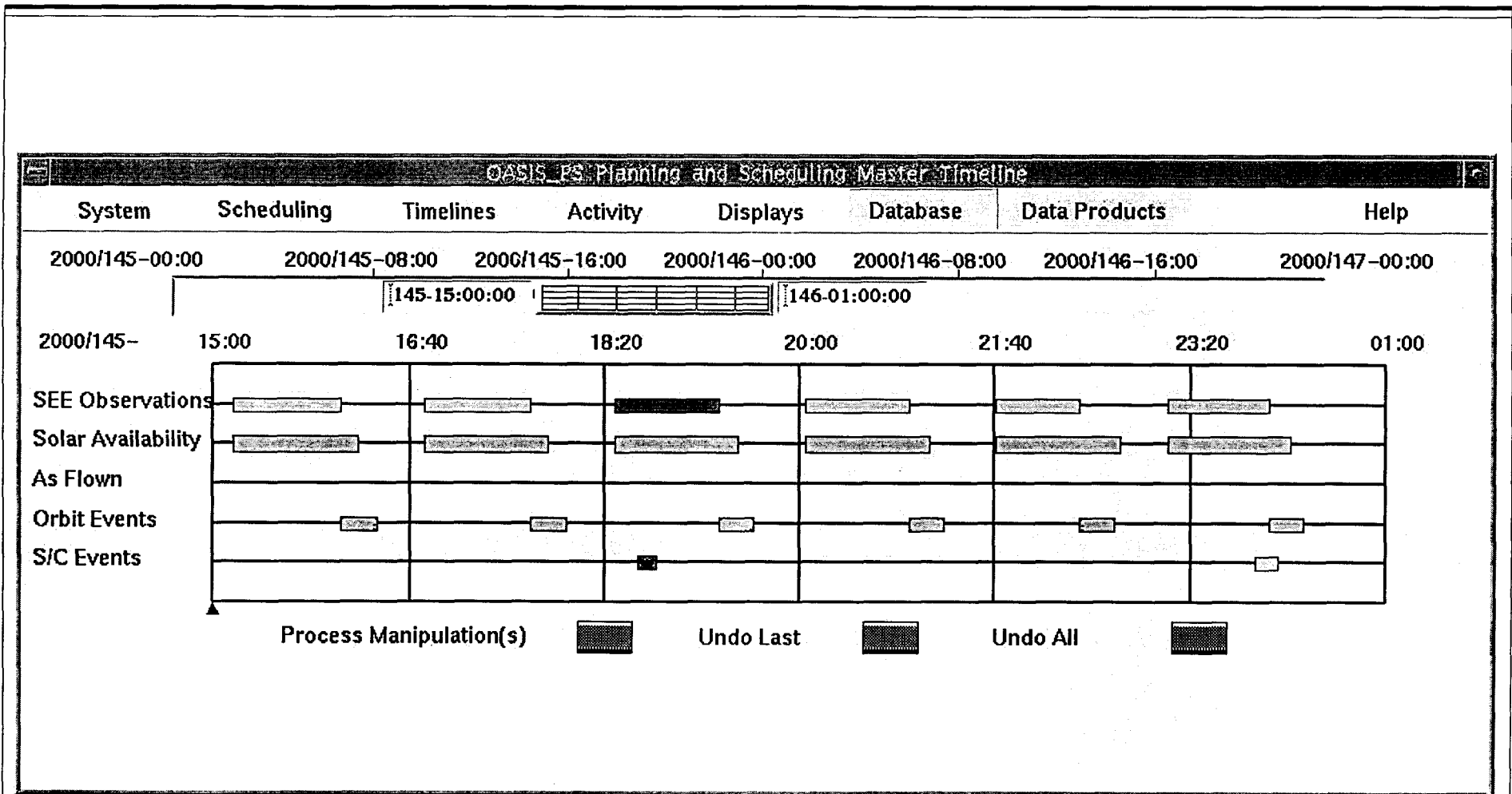

# NORMAL OPERATIONS



# SEE Normal Operations Timeline

Data Processing ftp planning products from MDC.

Data Processing ftp initial planning timelines to MDC.

Planning/Scheduling final timeline ftp to MDC.

OASIS-CC ftp CMFs to MOC.

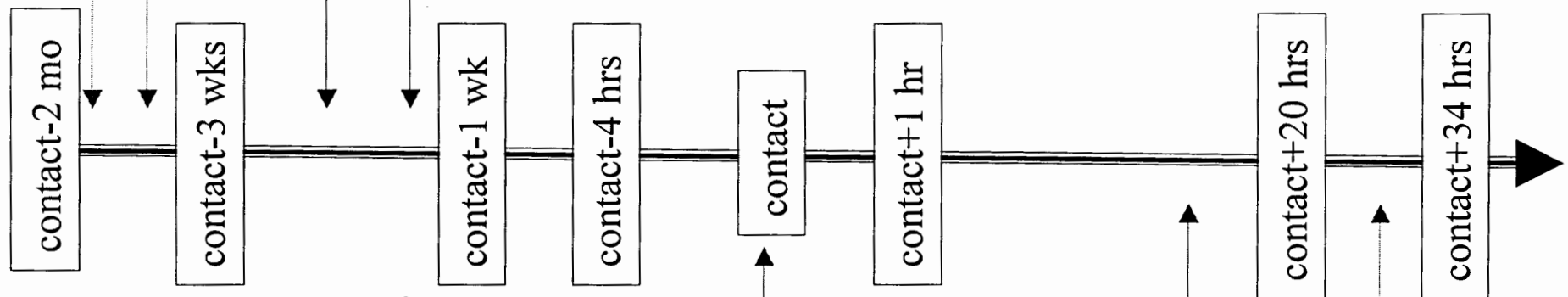

OASIS-CC monitors SEE;  
confirms command load.

Data Acquisition TCP/IP RT/PBK data from MDC.

Data Processing ftp as-flowns to MDC;  
notification of data products

# EARLY ORBIT OPERATIONS

# SEE Launch/Early Ops Timeline

**Flight and Test POC supporting S/C testing.**

**Test POC active for launch support, Flight POC monitoring.**

**Test POC supporting SEE & SSPP activation.**

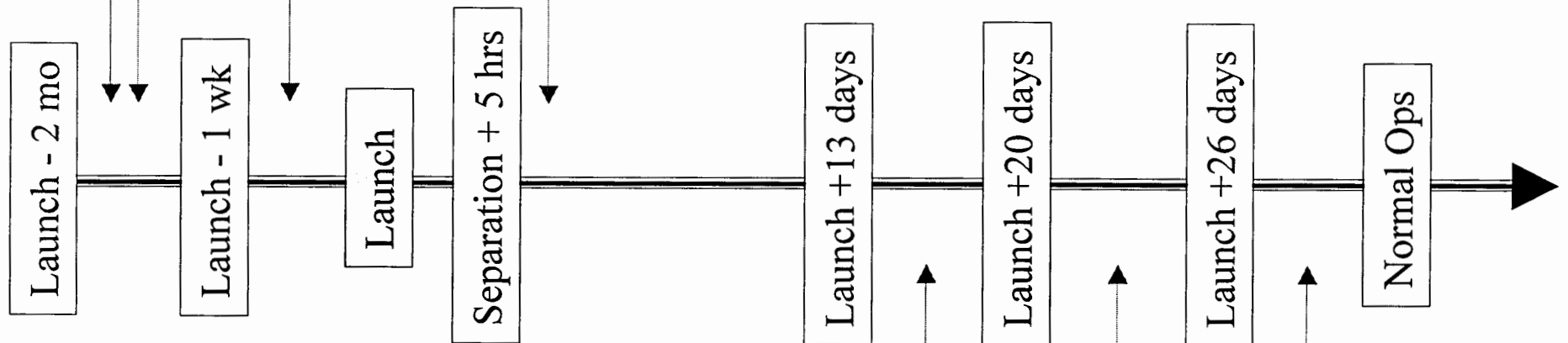

**Test POC primary for XPS activation;  
Planning/Scheduling system checkout.**

**Test POC primary for EGS activation.**

**FLIGHT POC loads ODCs  
generated by Planning/Scheduling system.**

# MONITORING & INSTRUMENT SAFETY

## Critical Commands - 1

**No single command  
can damage SEE.**

# Critical Commands - 2

- All commands have been tested.
- SEE hazardous commands are Dual-Commands
  - Hazardous conditions require
    - Enable command
    - Set command
  - Multiple command safety features:
    - Commands must execute consecutively & in order.
    - Enable command has a time-out period.
- Hardware Safing
  - Arming plug also protects SEE from hazardous commands. (All disable, HV only, Door only, Flight)

# High Voltage Commands

## □ HV operation

- Hazardous only when not under vacuum
  - Backfilled with N<sub>2</sub>
    - During transport to VAFB
    - After instrument final closeout until EGS door opens.

<b>Hazardous time period</b>	<b>Safing Mechanism</b>
I&T transport to VAFB	All-disable arming plug
Instrument final closeout through day L+23	HV enable command removed from database (Flight plug is in place)

# EGS Door Commands

- EGS Door operation
  - Hazardous ***ONLY IF*** the EGS Door opens  
***AND*** HV is on

Hazardous time period	Safing Mechanism
I&T	HV-only arming plug
I&T transport to VABF	All disable arming plug
Instrument final closeout	Door enable command will be removed from the database
Open EGS Door on day L+23	Add enable command. After door opens, remove it from the database. No further door operations planned.



# SSPP Commands

## □ SSPP operation

- Potentially hazardous if the SSPP hits a hard stop
  - Manufacturer recommendation
  - Safe zone is 5° from each hard stop (0° and 190°).

Hazardous time period	Safing Mechanism
I&T	Automatic response from ground software (OASIS-CC) turns off SSPP.  Autonomy rule will turn off SEE.
Flight	Autonomy rule will turn off SEE.

- Note: The SSPP can only be commanded to 0°-185°.

# Alarm and Safing Parameters -1

- In-flight : during contact
  - SEE flight POC
    - Limit checks of critical items
    - Yellow and Red limits define unsafe ranges/states of critical telemetry items.
  - MOC
    - MOC will inform SEE POC personnel of yellow/red limits
    - Visible telemetry items at the MOC:
      - SEE current - Red
      - SSPP Position - Yellow
      - High Voltage - Red

# Alarm and Safing Parameters -2

- In-flight : between contacts
  - 11 autonomy rules for SEE
    - Most autonomy rules turn SEE off.
      - Rules relate to:
        - Heartbeat
        - Temperature
        - SEE power
        - Survival heater power
        - High Voltage value
        - SSPP range

**The most likely Red limit the MOC will encounter is**

**Low SEE Current**

**(generally occurs after an autonomy rule fires)**

# CONTINGENCY OPERATIONS

# SEE Contingency Timeline

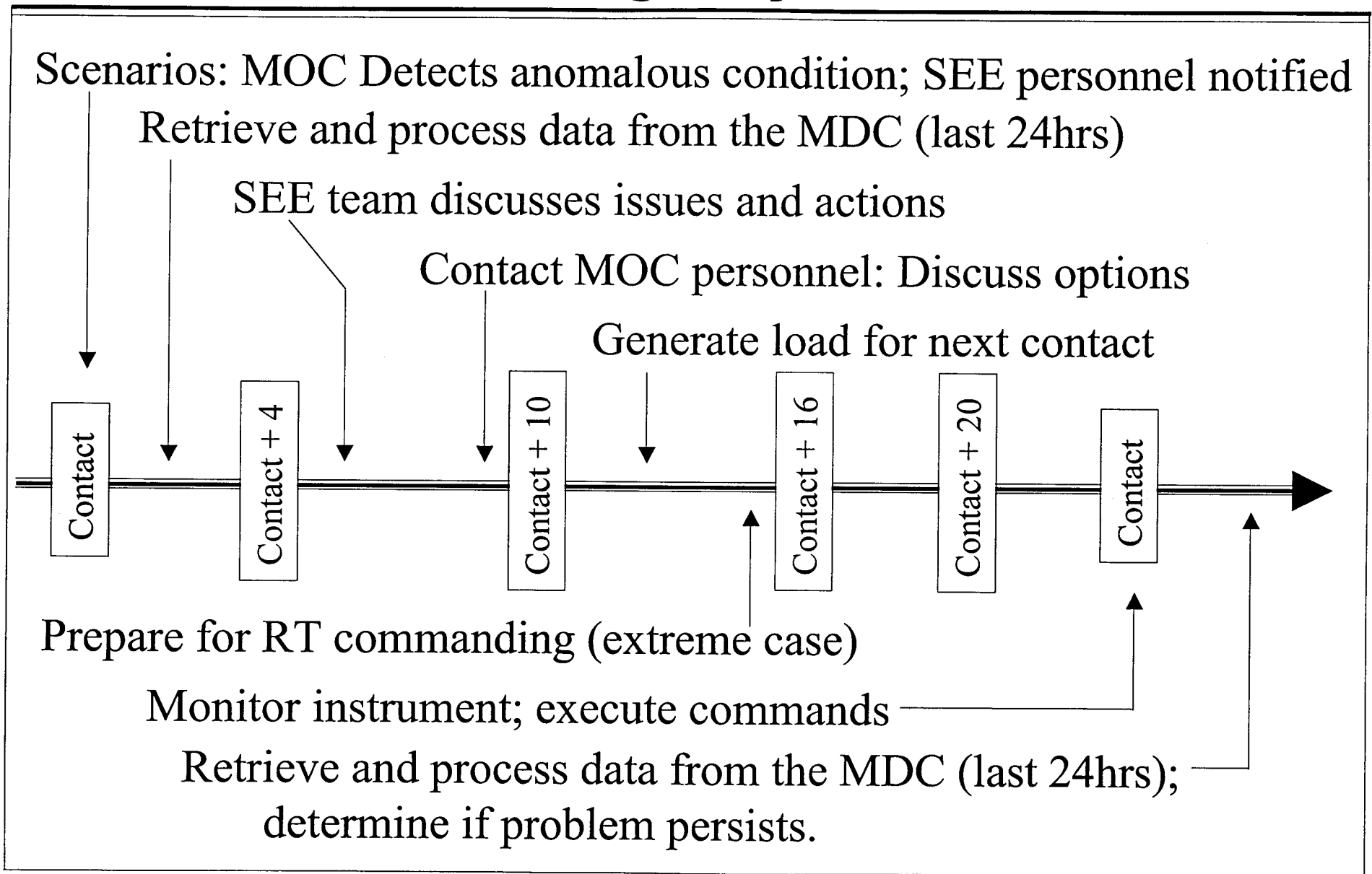

# SECURITY

# SEE POC Hardware/Security -1

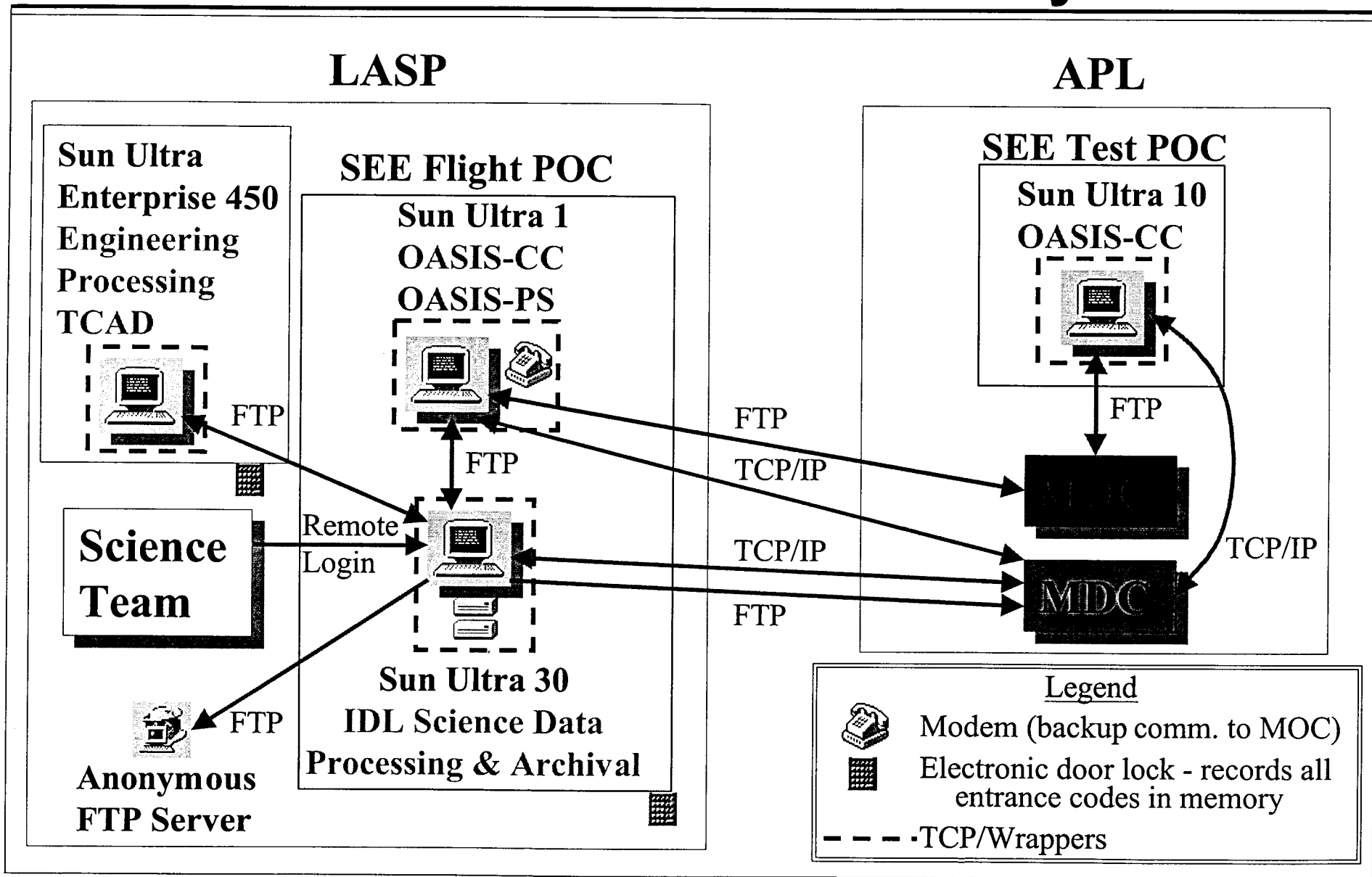

## SEE POC Hardware/Security -2

- TCP/Wrappers
  - Restricts access to specified IP addresses.
- Computer access
  - User accounts only (no anonymous access)
  - Timer activated screen saver/console lock
  - Flight account password changed every 6 months
  - Remote logins - secure shell only
    - Passwords and retrieved data are encrypted.



# SEE POC Hardware/Security -3

## □ Backup Systems

- Science data processing computer can replace the Flight commanding computer.
- Complete tape backup monthly
- Incremental backup daily
- SEE Test POC computer has off-site copy of RT-critical software.

# MISCELLANEOUS

# Software Configuration Management

<b>Subsystem</b>	<b>Configuration Control Method</b>
Monitor and Control (OASIS-CC)	Release account contains current and previous builds.
Data Acquisition	RCS – Revision Control System
Engineering Data Processing (TCAD)	COTS product
Science Data Processing (IDL)	CVS – Concurrent Versions System (based on RCS)
Planning/Scheduling (OASIS-PS)	RCS

Note: On-line change report forms will be used to track problems/issues.

# SEE POC Software Status

<b>Software</b>	<b>Status</b>	<b>Comments</b>
Monitor and Control (OASIS-CC)	Completed	System used throughout I&T.
Data Acquisition	Completed	Thoroughly tested.
Engineering Data Processing (TCAD)	90% completed	Testing system with real data.
Science Data Processing (IDL)	Completed	All processing levels completed
Planning/Scheduling (OASIS-PS)	80% completed	Scheduler and external communication in development.

# SEE POC Hardware Status

Hardware	Status	Comments
Computers	100 % Complete and in place.	Additional science analysis computers will be purchased during Phase E.
Data Storage Disks	90 % Complete and in place.	Disks have been purchased, and are being configured. More will be needed during Phase E.
Modem	50 % Complete	Additional telephone lines have been added to SEE POC. Modem is being configured.

All flight-critical software and hardware components are ready for flight.

# Personnel Assignments

	Launch	Early Ops	Normal Ops	Contingency
<b><i>Frank Eparvier</i></b> (Co-Investigator)	VAFB	LASP	LASP	LASP
<b><i>Gail Tate</i></b> (I&T Lead / Ground Software Manager)	APL	APL	LASP	APL/LASP
<b><i>Angela Williams</i></b> (Student)	LASP	LASP	LASP	LASP
<b><i>Don Woodraska</i></b> (Lead Programmer – Science Data Processing)	VAFB	LASP	LASP	LASP/APL
<b><i>Tom Woods</i></b> (Principal Investigator)	APL	APL	LASP	LASP

Other team members are also involved.

# Ground Software Documents

Title	Number	Status
TIMED SEE Security/Disaster Mitigation Plans	20550-0-0002	Rev. A
TIMED SEE Configuration Management Plan	20550-0-0117	Rev. A
TIMED SEE Data Processing Software Requirement Document	20550-0-0118	Rev. A
TIMED SEE Software Development Plan	20550-0-4001	Rev. B
TIMED SEE Software Quality Assurance Plan	20550-0-4002	Rev. A
TIMED SEE Ground Operations Requirements	20550-0-4201	Rev. A
TIMED SEE Concept of Operations	20550-0-4202	Rev. A
TIMED SEE Ground Software Design	20550-0-4203	Rev. B
TIMED SEE Operations and Planning Software Design	20550-0-4205	Rev. A
TIMED SEE Science Data Processing Design	20550-0-4301	Rev. F
TIMED SEE OASIS Reference Documents	Not under configuration management.	Available



## **TIDI POC**

**David A. Gell**

**734.763.6221 (voice)      734.763.7130 (fax)**

**gellda@umich.edu**



- **POC Overview**
  - **Hardware Configuration**
  - **Software Data Flow**
- **Hardware Status**
- **Mission Operations Software Status**
- **Operations**
  - **Initial Operations**
  - **Normal**
  - **Contingency**
- **POC Contingency**
- **Science Data Processing**

# Overview Hardware Configuration

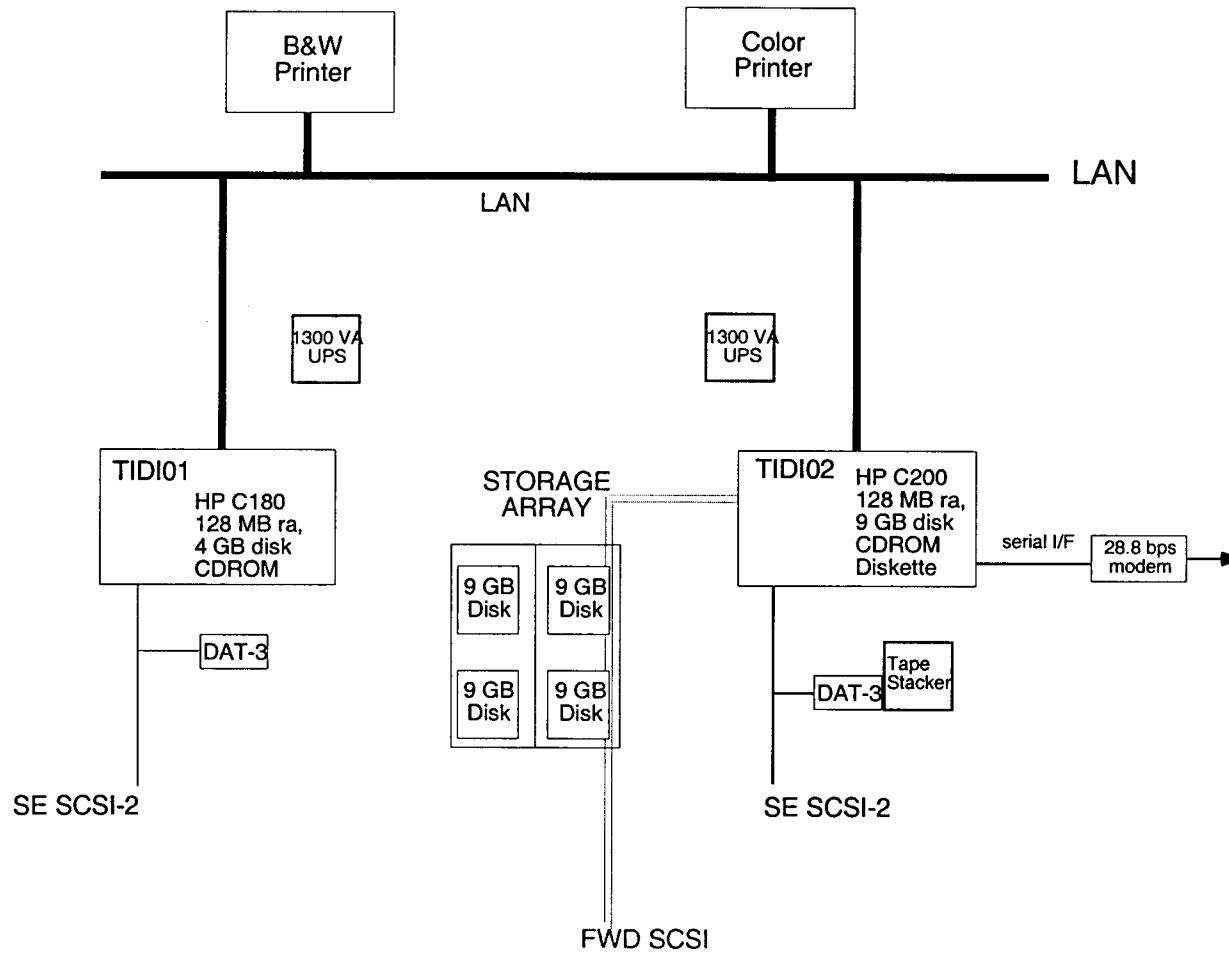



# TIDI

## Overview Downlink Software Data Flow

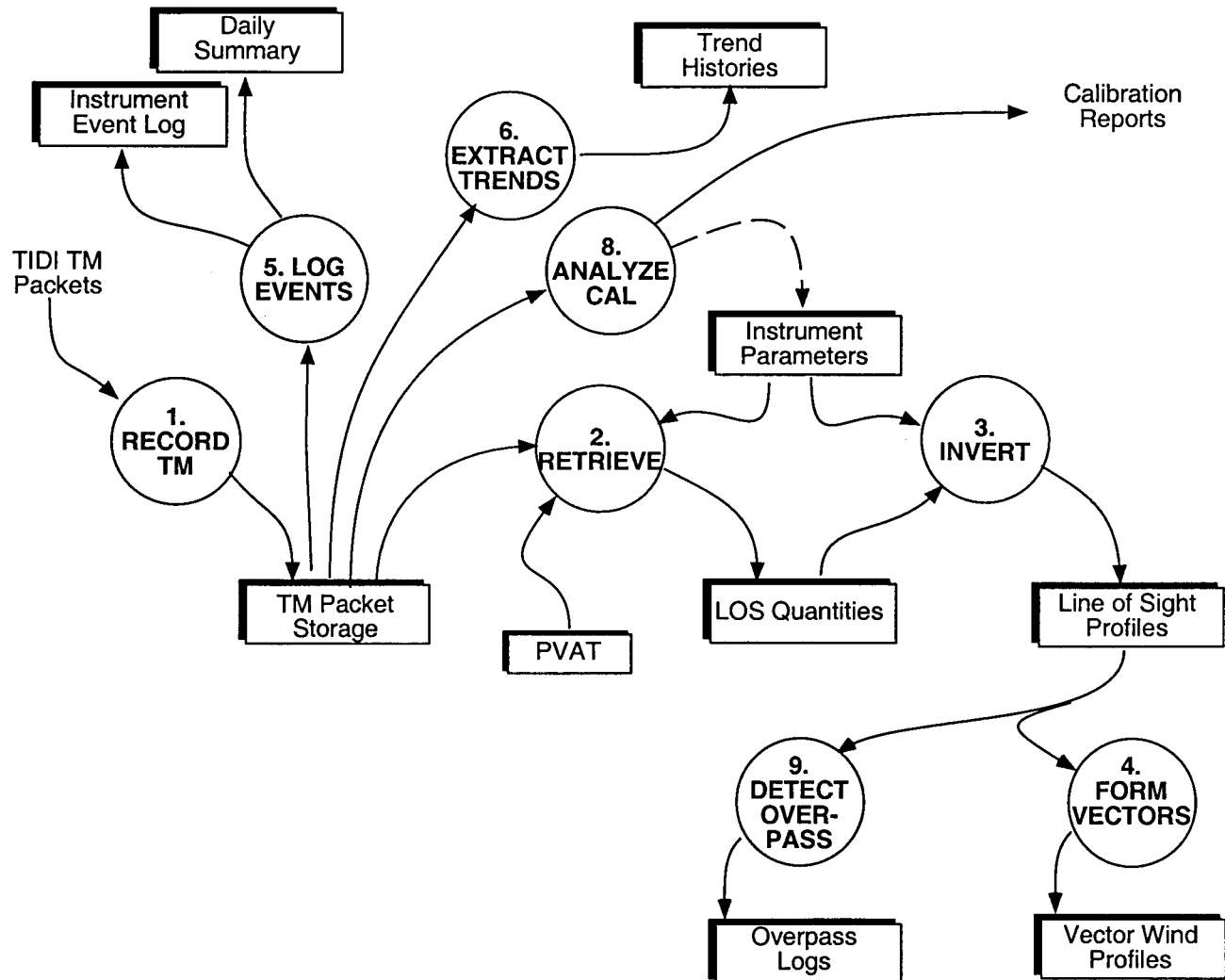

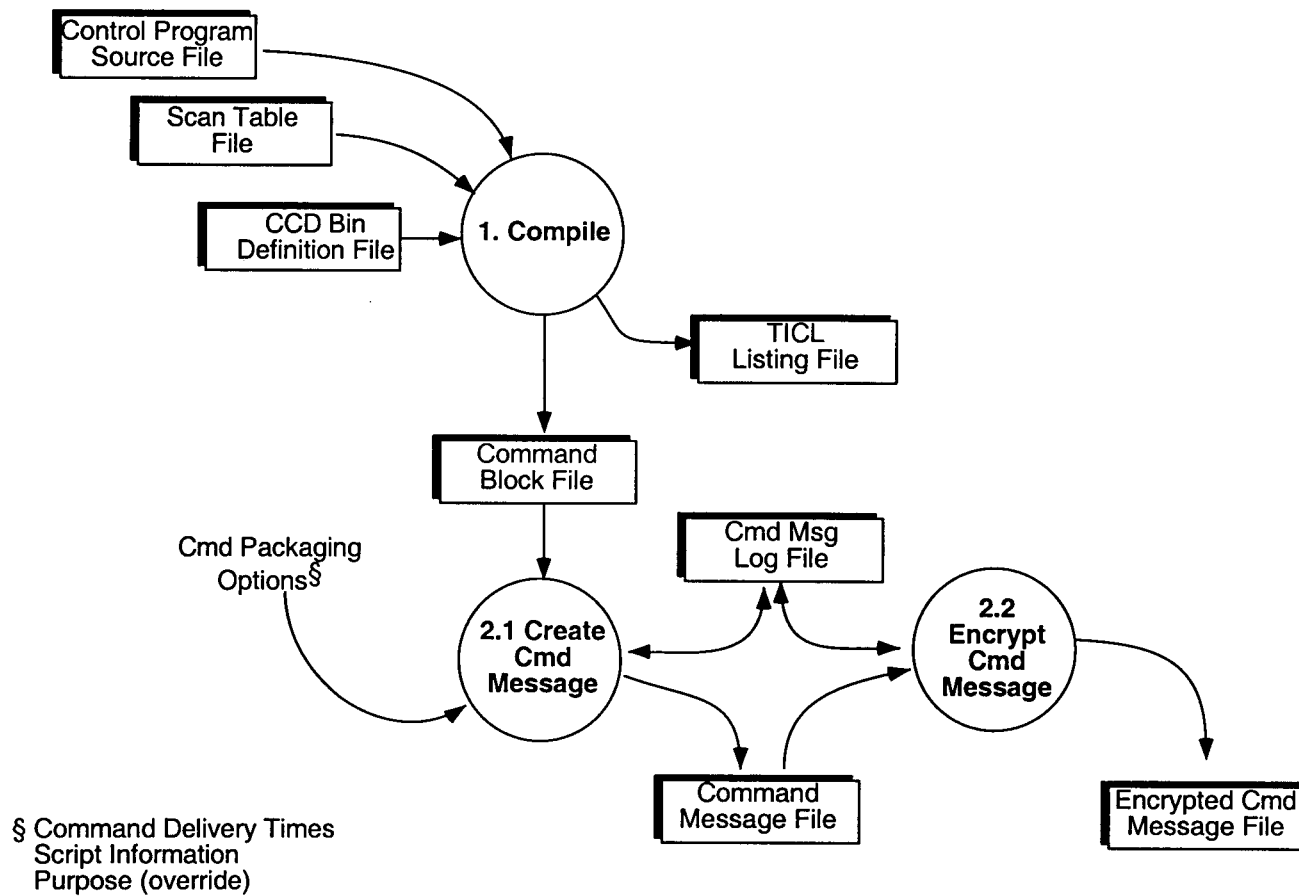

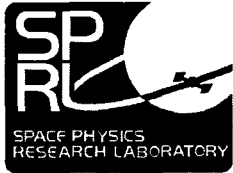

**TIDI**

# Hardware Status Computer System Configuration

---

- **TIDI POC Hardware**
  - **2 HP workstations**
  - **Disk array**
  - **28.8 bps modem**
  - **Tape backup systems**
  - **Uninterruptable power supplies**
  - **Printers**
- **Equipment installed and configured**
- **Modem connection has been exercised**



- **Downlink Software**

1	tmLogger	in production - v1.0
6	Trend	in production - v1.0
8	Analyze	in production - v1.0
2	Retrieve	in development
3	Invert	in development
4	Vector	in development

- **Uplink Software**

1	ticl Compiler	in production - v1.4
2.1	package	in production - v1.1
2.2	sendCM	in production - v1.0



# Mission Operations Software Status Components

---

- **Command Path**
  - TIDI Instrument Command Language Compiler (TICL)
  - Command Message Formatter
  - PGP Encryption
- **Return Path**
  - TM Logger
  - Event Logger
  - TM Query (Ad-Hoc TM report)
  - Instrument Parameter Definitions (055-3519AC) specifies alarm limits used in Event Logger, OASIS, and in flight software
- **Realtime**
  - OASIS displays
  - OASIS interface with TM data source emulator  
MDC
  - OASIS interface with Command Message Formatter



# Mission Operations Software Status Command Path

---

- **TICL Compiler**
  - Testing by exhaustive trials
    - Each language construct exercised
    - Resulting command block file examined manually
  - Test cases and results preserved for reversion testing
  - Testing is complete
- **Command Message Formatter**
  - Testing by inspection
    - examine output of command message formatter
      - header correct
      - binary message content correct
  - Testing is complete





# Mission Operations Software Status Return Path

---

- **TM Logger**
  - Test MDC protocol with emulator, completed
  - Test decommutation, completed
  - Test access API, complete
  - Verify engineering unit conversions
- **Event Logger**
  - Test with synthetic data
  - Test during instrument calibration
  - Testing complete
- **TM Query**
  - Test with synthetic data, in process
  - Testing complete



**TIDI**

# Mission Operations Software Status Realtime

---

- **OASIS displays**
  - Tested by inspection
- **OASIS interface with TM data source**
  - Emulator, tested during instrument integration
  - MDC, tested during spacecraft integration
- **OASIS interface with Command Message Formatter**
  - Uses same script (sendCM) as routine operations
  - Tested with emulator, operations confirmed during instrument integration with the spacecraft.

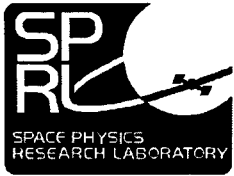

# TIDI

## Operations

- **Launch and Early Ops**
  - **Activation scenario documented in Gell, D.A. “TIDI Instrument Activation Scenario”, SPRL 055-3757E**
  - **CSTOL Procedures and TIDI Instrument Command Language (TICL) programs have been tested as part of the spacecraft mission operations simulation**
- **Normal**
  - **Data collection programs specified in several documents:  
Skinner, W.R. “Daylight High Beta Angle Mode”, SPRL 055-3910  
Skinner, W.R. “Flight Calibration Sequence”, SPRL 055-3917  
Gell, D.A., “Measurement Sequence Specifications”, SPRL 055-3431**
  - **Operating Procedures  
Gell, D.A., “TIDI Operations Checklists”, SPRL 055-3886**
  - **Standard data collection programs have been tested as part of the spacecraft mission operations simulations**
- **Contingency**



**TIDI**

---

# Initial Operations

- **Goals**
  - **Confirm that the instrument has not been affected by launch**
  - **Configure instrument for initial operations**
- **Phases**
  - **Outgasing**
  - **Initial Turn on and Checkout**
  - **Initial Data Collection**
- **Documentation:**
  - **Requirements:**  
**Gell, D.A. "TIDI Instrument Activation Scenario",  
SPRL 055-3757E**
  - **Operating Procedures:**  
**Gell, D.A., "TIDI Operations Checklists", SPRL 055-3886**



## Initial Operations Restrictions

---

- **Real time instrument operations are limited to 5 minutes duration.**
- **Power commands are issued by the spacecraft controllers. Coordination will require voice communications between the MOC and the TIDI POC.**
- **Telescope cover deployment may not occur until the outgassing period has been completed. Deployment will be on the night side of the orbit.**
- **Instrument activation is to be completed in time to permit measurements during the first solstice period after launch.**

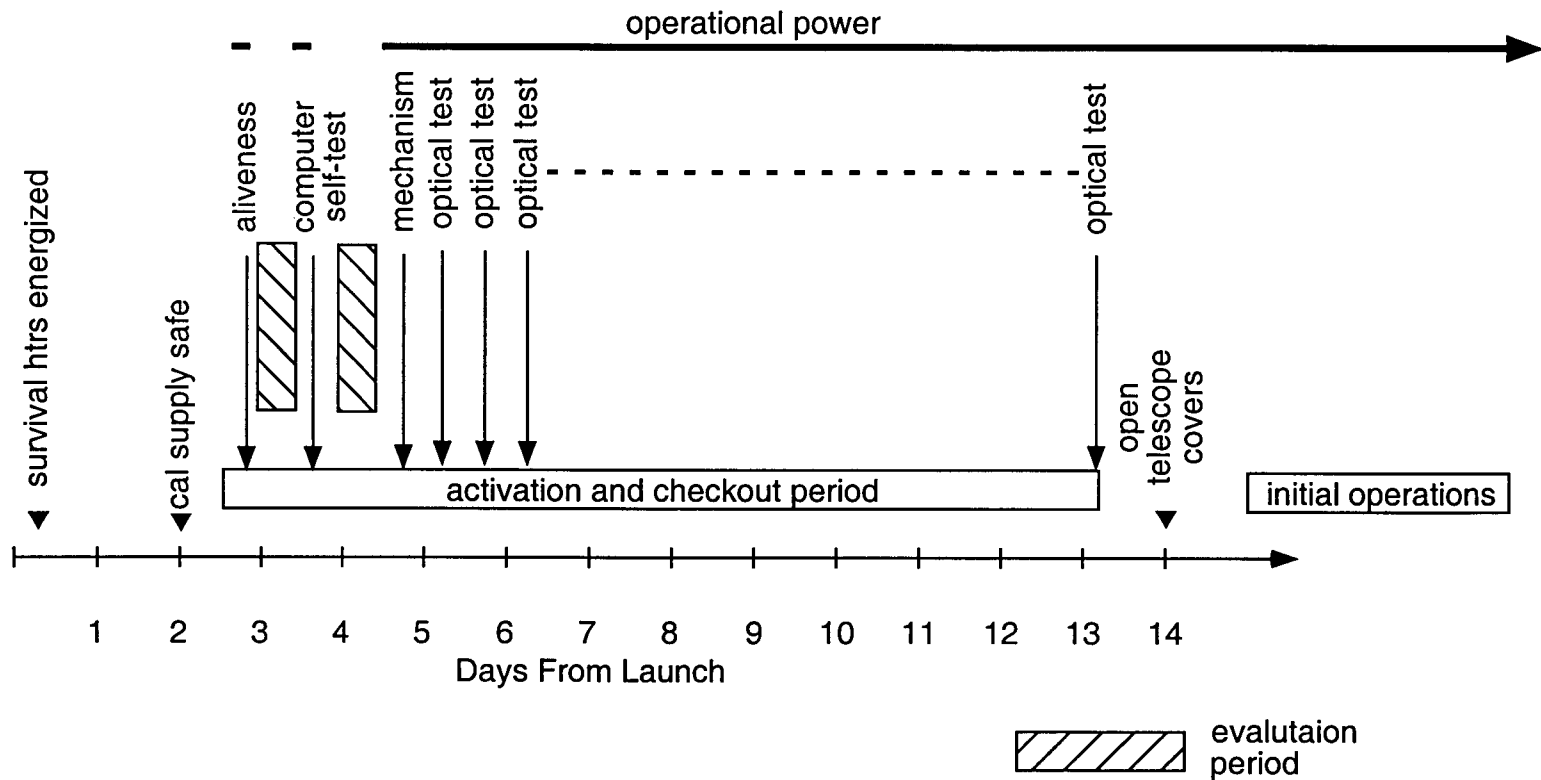

- **Outgassing is required to maintain optical cleanliness**
- **14 days is desired duration**
  - Covers remain closed
  - Activation can begin at launch plus two days
- **While the instrument is off**
  - survival heaters active
  - Instrument health monitored with passive temperature monitors

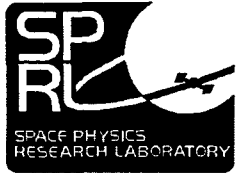

**TIDI**

## **Initial Operations Turn On and Checkout**

---

- **Timeline depends on frequency of communications during initial operations period**
- **Initiated on third day after launch or anytime thereafter**
- **Steps include**
  - **Aliveness Test**
  - **Computer Self Test**
  - **Mechanism Functional Test**
  - **Optical Test**
  - **Release Telescope Covers**
- **Normal TM contains enough information for evaluation**
- **Each step is evaluated prior to advancing to the next**



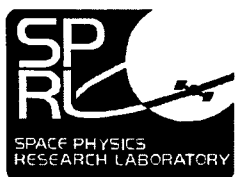

TIDI

# Turn On and Checkout Resources

Activation Resources				
	duration	command volume	real-time stored	TM rate
test	minutes	bytes		
Aliveness	5	10	real time	normal
Computer Self Test	5	10	real time	normal
Mechanism Test	5	2000	real time	normal
Optical Test		5000	stored	normal
Cover Deployment	5	~100	real time	normal



## Turn On and Checkout Steps - I Aliveness Test

---

- **Performed during a real time contact**
- **Power is applied to the instrument**
- **A no-op command is transmitted**
- **Sufficient time is allowed for the generation of housekeeping TM**
- **Power is removed from the instrument**
- **Duration, less than 5 minutes**



## Turn On and Checkout Steps - II Computer Self Test

---

- **Performed during a real time contact**
- **Power is applied to the instrument**
- **Self test is performed by transmitting commands to perform CRC check over primary and secondary copies of instrument software**
- **Sufficient time is allowed for the generation of housekeeping TM, including status messages resulting from the self test**
- **Power is removed from the instrument**
- **Duration, less than 5 minutes**



**TIDI**

## **Turn On and Checkout Steps - III Mechanism Functional Test**

---

- **Initiated by program control**
- **Each mechanism is exercised over its normal range of states**
- **Repeats the TIDI mechanism functional (EPET) test**
- **Housekeeping TM collected during the test is used to evaluate the test**
- **The instrument remains powered at the end of the test**



**TIDI**

## Turn On and Checkout Steps - IV Optical Test

---

- **Initiated by program control**
- **On board calibration sources used to confirm that the instrument optical performance is as expected**
- **Repeats the TIDI optical evaluation (EPET) test**
- **Housekeeping and Science TM collected during the test is used to evaluate the test**
- **Performed periodically during activation period prior to telescope cover deployment**



**TIDI**

## Turn On and Checkout Steps - V Telescope Cover Release

---

- **Performed during orbit night**
- **Performed during a real time contact**
- **Instrument is configured by TIDI POC**
- **Pyro commands required are sent by spacecraft operators**



## Initial Operations Initial Data Collection

---

- **Initiated after telescope covers are deployed**
- **Performed using normal command delivery and TM collection**
- **Normal TM contains sufficient information for evaluation**
- **Initial Data Collection consists of three operations**
  - **Optical continuity and alignment confirmation**
  - **Atmospheric Line Survey**
  - **Initial science data collection**



**TIDI**

# Initial Data Collection Resources

Initial Operations Resources			
	duration	command volume	TM rate
operation	hours	bytes (msgs)	
Optical Continuity and Alignment Confirmation	24	11000 (45)	normal
Line Survey	24	13000 (53)	normal
Initial Science Data Collection	24	7000 (29)	normal



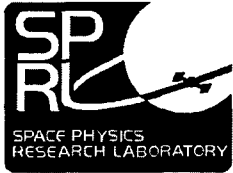

**TIDI**

## **Initial Data Collection - I Continuity & Alignment Confirmation**

---

- **During orbit night**
  - Views the “green line” emission of atomic oxygen
  - scans from 80 to 100 km
  - Provides initial alignment confirmation
- **During orbit day**
  - scans from 0 through 100 km through each filter for an orbit
  - provides
    - confirmation of optical continuity
    - instrument normalization
    - telescope scattering performance
- **Performed using normal command delivery and TM collection**

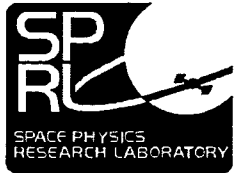

**TIDI**

---

## Initial Operations - II Line Survey

- **Views each atmospheric feature over altitude range**
- **Spectral line shapes obtained for each feature**
- **Line of sight brightness profiles obtained for each feature**
- **Confirms**
  - **signal levels**
  - **altitude ranges**
  - **absence of contaminating signals**
- **Performed using normal command delivery and TM collection**

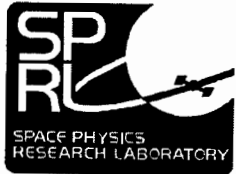

**TIDI**

## **Initial Operations - III Initial Data Collection**

---

- **Provides first “real” data to data processing system**
- **Results examined to confirm validity of assumptions in data collection**
  - **Signal level**
  - **Altitude distribution**
  - **Geographic distribution**
- **Each data collection program defined at launch exercised**
  - **Confirm the operation of the data processing with actual data**
- **Performed using normal command delivery and TM collection**

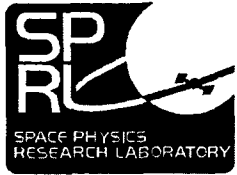

**TIDI**

# Normal Operations Topics

---

- **Overview**
- **Uplink**
  - **Activities**
  - **Timeline**
- **Downlink**
  - **Activities**
  - **Timeline**
  - **Quicklook**
- **Contingency**



**TIDI**

# Normal Operations Overview

---

- **Mission Operations Consists of**
  - **Uplink Operations**
    - Command Planning**
    - Command Generation**
    - Command Transmission**
  - **Downlink Operations**
    - Instrument Health and Safety Monitoring**
    - Operations Monitoring**
    - Data Logging**
  - **Anomaly Resolution**

- **Mission Planning**
  - Develop TIDI observation plan, implementing TIMED science goals
  - Coordinate Special Campaigns
- **Command Planning**
  - Develop detailed observation program
  - Specify, Code and Test instrument control programs
  - Coordinate with correlative measurement sites as needed
- **Command Execution**
  - Transfer command loads to spacecraft control center
  - Verify receipt and execution



# Normal Operations Uplink Operations Timeline

Time	Operation
D - 8 weeks D - 4 weeks	Receive predicted orbitaphemerides
D - 4 weeks	Produce viewing geometry predictions Specify measurements
D - 4 weeks	Determine correlative measurement opportunities Transmit overpass predictions to correlative sites
D - 3 weeks	Complete specification of instrument control program
D - 2 weeks	Complete coding and simulator verification of control program
D - 1 week	Transfer control program to TIMED control center for upload
D - 1 day	MOCC uploads TIDI control program at any time during the day
0	Operational Day, execute command program currently in instrument

- **Monitors the instrument health**
  - Uses automated procedures
  - reports limits violations
  - maintains trends of important parameters
- **Monitors instrument operation**
  - confirms receipt of command loads at TIMED MOCC
  - confirms receipt of command loads at the instrument
  - confirms measurements are as planned
- **Anomalies are recognized and resolution activities begun**





- **Provides tools for instrument health and safety monitor**
  - Event Logger
  - Trend Extractor
- **Examines a short data sequence from each contact**
- **Reports**
  - limit violations
  - instrument configuration
- **Extracts**
  - engineering trend data
  - state sequence information
- **Produces plots**

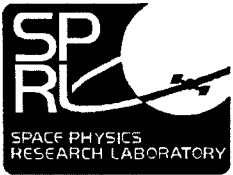

**TIDI**

## Operations Contingency

---

- **TIDI Contingency Philosophy:**
  - Safe the instrument and think about the problem then take action**
- **Instrument Autonomy**
  - **Sun avoidance: Prevents direct view of sun by fully depressing any telescope within 15° of the sun and closing the shutter**
  - **Instrument safing: When the spacecraft status message indicates a non-operational attitude state, invalid attitude or sun vector, or the status is stale TIDI enters a safe mode with all telescopes fully depressed and shutters closed.**
- **Spacecraft Autonomy**
  - **Instrument autonomy bit is asserted when a high operating current is sensed. Spacecraft autonomy rule removes operational power from TIDI.**
  - **Spacecraft autonomy rule resets TIDI when the heartbeat stops.**



- **Physical Risks**
  - Short Term Power Failures
  - Long Term Power Failures
  - Physical Loss of the POC
  - Network Interruptions
- **Security**
  - Goals
  - Tools

- **Disruptions due to power failure, facility loss and communications are minimized by the TIDI operations scenario**
  - TIDI command messages are queued well in advance
  - TIDI will continue to operate based on the last successfully received command message without risk
  - Direct communications with the MOC are possible via modem and PPP
- **Disruptions are avoided by the use of UPS to minimize the effect of short term power problems**
- **The TIDI POC can be quickly relocated in the event of a building fire or similar event since it consists of workstation class components and peripherals.**
- **The TIDI POC can be quickly recreated in the event of a total loss since the workstations are easily available and routine image backups will be created and stored off-site.**



## POC Contingency Security Goals

---

- **Prevent users from inadvertently interfering with each other**
- **Prevent malicious tampering with data, programs or operating systems**
- **Prevent unauthorized use of the system**
- **Prevent unauthorized transmission of commands**
- **Prevent unauthorized access to the MDC and MOC**

- **TIDI POC is physically secure, in a locked room with access limited to authorized individuals**
- **User accounts**
  - no shared accounts will be authorized, each user is issued an individual account
  - user privileges are set appropriately
- **NFS mounts of the TIDI disks will not be enabled.**
- **PGP Key files on dismountable media**
- **TCP wrappers are used to control access**
- **Remote telnet terminal access via secure shell (ssh)**
- **Security patches maintained up to date by the system administrator.**

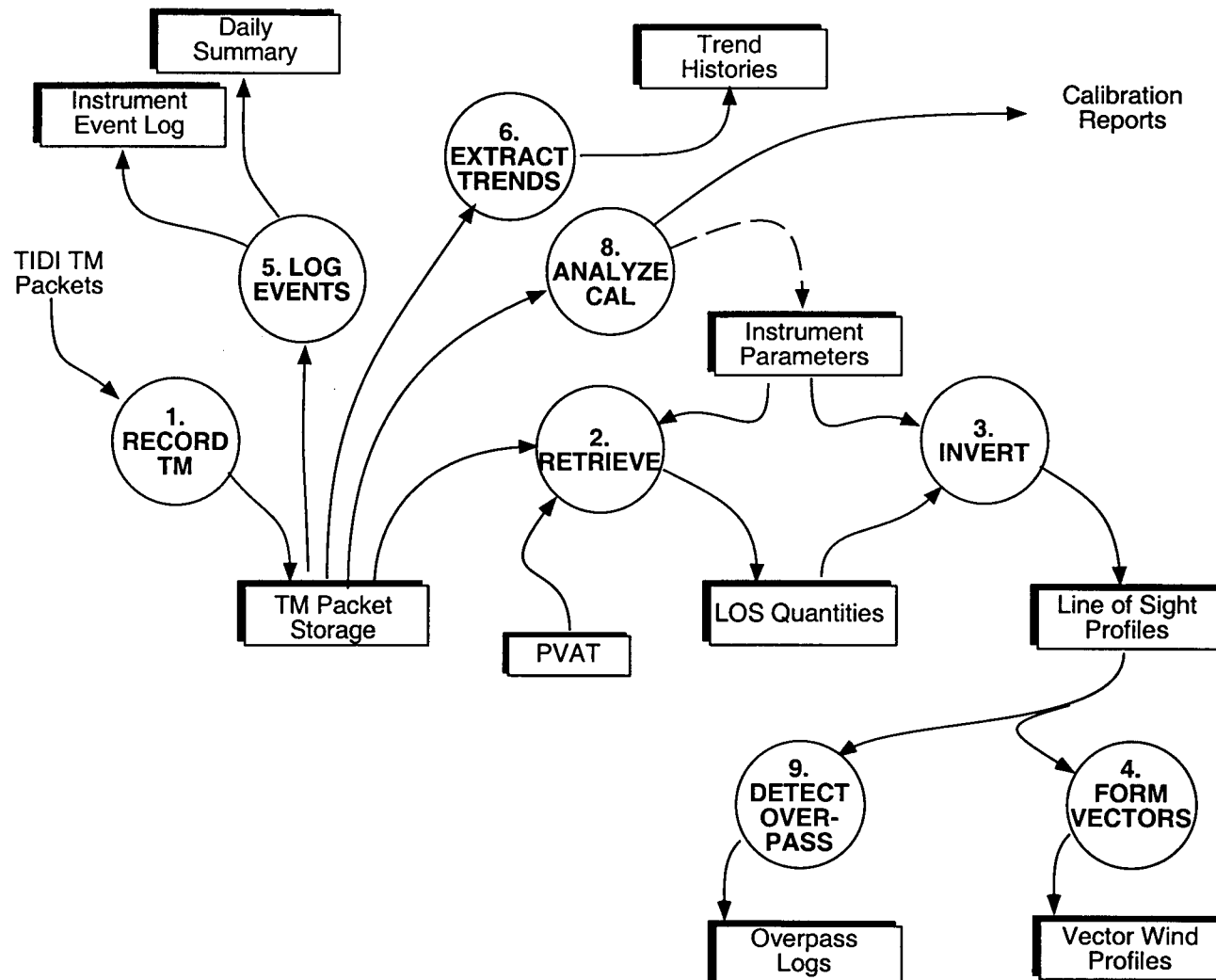



- **Retrieve**
  - Gell, D.A. “RETRIEVE Requirements Specification”, SPRL 055-3533, 28 October 1998
  - Niciejewski, R., Gell, D.A. “RETRIEVE Design Review”, SPRL 055-3692, 17 November 1998
- **Invert**
  - Gell, D.A. “INVERT Requirements Specification”, SPRL 055-3534A, 19 February 1999
  - Design in progress
- **Vector**
  - Requirements document pending
  - Design in progress



---

# GUVI POC

Bernard Ogorzalek

JHU/APL

Phone 240-228-8460

[bernie.ogorzalek@jhuapl.edu](mailto:bernie.ogorzalek@jhuapl.edu)



# POC Description

---

- The GUVI POC consists of two segments
  - Engineering POC (EPOC)
    - Commanding
    - Health, Status, and Trending
  - Data Processing POC (DP POC)
    - Routine Data Processing
    - Data Access and Distribution



# EPOC Requirements

---

- Commanding
  - Command generation and verification
  - Authentication
  - Archive of commands sent
  - Planning tools
- Health, Status, and Trending
  - Displays
  - Limit checks and alarms
  - Trending
  - Archive of instrument anomalies
  - Autonomous operation



# EPOC Description

---

- Platform
  - PowerMac G3 Computer
  - Custom application developed by Aerospace
- Location
  - TIMED MOC building at APL (room M6-110)



# DP POC Requirements

---

- Routine Data Processing
  - Data retrieval
  - Data reformatting
  - Data quality assessment
  - Construction of graphical overlays
  - Calibration, geolocation, and gridding
  - Algorithms (day, night, auroral)



# DP POC Requirements

---

- Data Access and Distribution
  - User interface
  - Data distribution
  - Survey products
  - Data catalog
  - Planning tools
  - Data server
  - Data archive
  - Archive of instrument calibration



# DP POC Description

---

- Platform
  - Unix platform (HP-UX)
  - Software developed by APL
- Location
  - APL building 4 (SRS group area)





# GUVI POC Interfaces

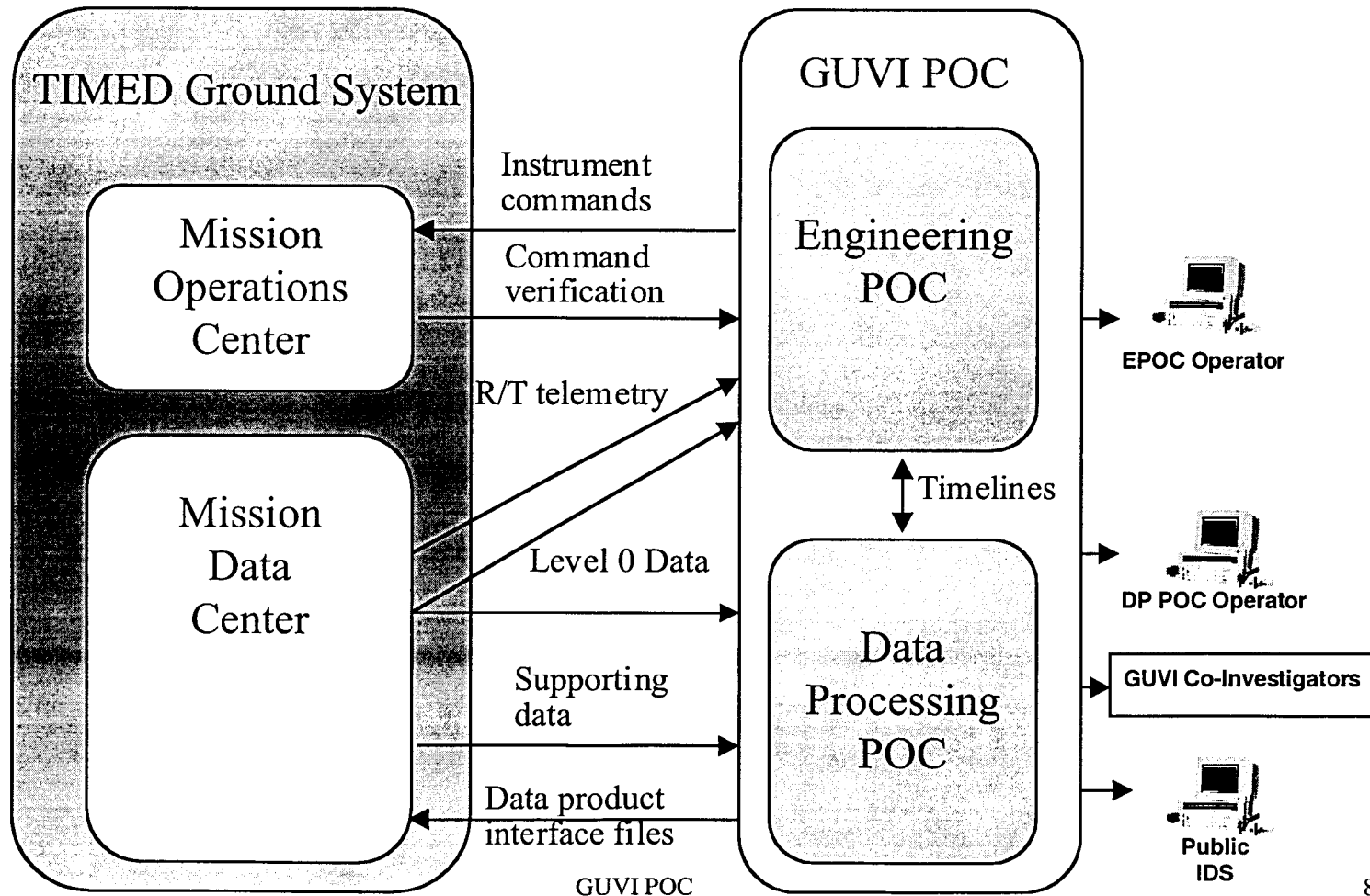



# EPOC Status

---

- Hardware
  - Two Power Mac G3 computers purchased in 1998
  - One computer needed, the second is a spare
  - Both computers have been used during all GUVI stand alone tests and spacecraft tests



# EPOC Status

---

- Software
  - Latest version of EPOC application is version 5.0
  - This version contains all commanding, display, limit checking, and alarm functions
  - One more version to be created before launch with features for autonomous operation
    - Continuous polling of MDC for playback data
    - Automatic generation of trending data



# DP POC Status

---

- Hardware
  - Unix platform (HP-UX)
  - Purchase requisition generated in October 2000
  - Available Unix machines being used for software development



# DP POC Status

---

- Data Product Status
  - Data product files
    - Level 1A - done
    - Level 1B - done
    - Level 1C - 75% complete
    - Level 2B - 25 % complete
  - Supporting data product files
    - GUVI Housekeeping file - done
    - Dynamic Overlay files - complete by launch
    - GUVI Pointing Information - complete by launch



# DP POC Status

---

- Algorithm Status
  - Calibration algorithm - done
  - Auroral e-region algorithm - done
  - Validation activities ongoing for
    - Calibration algorithm
    - Auroral e-region algorithm
    - Dayside algorithm
    - Nightside algorithm



# DP POC Status

---

- DP POC software is currently
  - Ingesting Level 0 telemetry from MDC
  - Producing Level 1A and 1B data products
  - Retrieving TIMED/MDC supporting data files from MDC
  - Automatically producing Product Availability Notice and Science Data Producer's URL
  - Manually producing planned and as-flown timelines



# DP POC Status

---

- Software to complete by launch
  - Production of GUVI Level 1C data files
  - Production of some of GUVI Supporting Data Files
  - Delivery of routine GUVI data products via GUVI web site
  - Graphical display of GUVI Level 1C & 2B data products





# GUVI Operations

---

- Early Orbit
- Normal On-Orbit
- Monitoring
- Trending
- Contingency Plans



# Early Orbit Operations

---

- Before SIS Cover Opened
  - Start abbreviated functional test at launch + 7 days
  - Test telemetry interface, SIS mechanisms, and detector aliveness/dark count
- Open SIS cover at launch + 14 days
- After SIS Cover Opened
  - Scan motor test
  - Detector characterization tests
  - Stellar calibrations
  - Off-nadir pointing tests
  - Begin normal imaging mode operation



# Normal Operations

---

- Commanding
  - Imaging mode is normal operating mode
  - GUVI command packets will be uploaded once per week for any mode changes planned during that week
  - Command upload will typically consist of one command packet
  - GUVI flight instrument stores time tagged commands
  - Only regularly scheduled mode change will be to transition from imaging mode to calibration mode once per month
  - Planned and as-flown timelines will be generated once per week



# Normal Operations

---

- Engineering Data Processing
  - EPOC operates autonomously
  - EPOC continuously polls MDC for new data
  - New data available from MDC every 24 hours
  - EPOC will complete engineering data processing within 6 hours after new data available (for 24 hours of data)
  - Alarms and pages generated when out of limit parameters detected during playback of engineering data
  - EPOC saves a log file of commands, mode changes, and alarms
  - EPOC saves trending data files



# Normal Operations

---

- Science Data Processing
  - DP POC operates autonomously
  - DP POC continuously polls MDC for new data
  - New data available from MDC every 24 hours
  - DP POC will complete science data processing within 24 hours after new data available (for 24 hours of data)
  - Data products will be available on web server within 24 hours after new data available



# Normal Operations

---

- On-Orbit Calibration
  - Calibration to be performed once per month
  - Calibration mode duration is 5 minutes per orbit for 3 to 5 orbits
  - Calibration Sequence
    - At predetermined time, switch to spectrograph mode with scan mirror pointing at star
    - After 5 minutes, return to imaging mode
    - Repeat for 3 to 5 consecutive orbits
  - Time tagged commands to control sequence of events



# Autonomous Operation

---

- GUVI enters a safe mode during the following events
  - Yaw Maneuver
  - Power Down Warning Flag
  - GUVI Bright Object Detection
- Detector high voltage and scan motor power are turned off during the GUVI safe mode
- GUVI will return to previous operating state after end of yaw maneuver and clear of power down warning flag
- If bright object event occurs, GUVI remains in safe mode until ground commands are sent
- Spacecraft autonomy checks GUVI heartbeat, bus currents, and SIS temperature



# Monitoring

---

- EPOC displays all GUVI housekeeping parameters
  - Temperatures, bus currents, high voltage levels, count rates, motor position telltales
- Red and yellow limit checks are performed on housekeeping parameters
- Any housekeeping parameter can be defined as an alarm parameter
- Alarms, commands, and mode changes are entered in the EPOC log
- A phone page can sent for any alarm event





# Trending

---

- EPOC generates trend data during engineering data processing
- Trend parameters will consist of
  - Analog housekeeping parameters (temperatures, bus currents, high voltage level)
  - Motor position indicators
  - Dark counts
  - Background counts (scatter indication)
  - Tube pulse height distribution
  - Detector responsivity (from monthly stellar calibrations)



# Contingency Plans

---

- Engineering Data Processing
  - EPOC will detect out-of-limit parameters
  - EPOC generates a phone page for designated out-of-limit parameters
  - GUVI system engineer is responsible for evaluating anomalous condition and generating plan of action
  - GUVI instrument contains redundant detectors and motor drive circuits if needed



# Contingency Plans

---

- Science Data Processing
  - DP POC generates a log file of software processing errors and automatically spotted anomalies
  - E-mail sent to DP POC operator for severe errors



# Personnel

---

- Part time support is planned for the EPOC and DP POC
- Continuous staffing not required during normal operations
- Instrument health checks and commanding will be performed weekly by the EPOC operator
- Data quality checks will be performed weekly by the DP POC operator.
- 3 EPOC operators are available for backup coverage



***TIMED***

*Thermosphere Ionosphere Mesosphere Energetics Dynamics  
Flight Operations Review*

---



# Spacecraft Testing

Mike Packard

Phone: 240-228-3516

e-mail: [michael.packard@jhuapl.edu](mailto:michael.packard@jhuapl.edu)

The Johns Hopkins University  
Applied Physics Laboratory  
Laurel, Maryland 20723

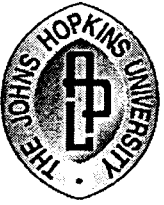

# ***TIMED***

*Thermosphere Ionosphere Mesosphere Energetics Dynamics  
Flight Operations Review*

---

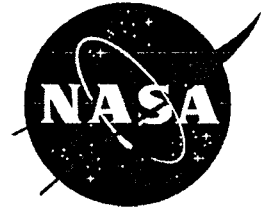

## SC Environmental Testing

- " EMC
  - October 28, 1999
- " Vibration
  - October 28, 1999 - October 29, 1999
- " Acoustic
  - November 12, 1999
- " Pyro Shock
  - November 18, 1999



# *TIMED*

*Thermosphere Ionosphere Mesosphere Energetics Dynamics  
Flight Operations Review*

---



## SC Environmental Testing (con't)

- " TV
  - Balance
    - " December 11, 1999 - December 22, 1999
  - Cycle
    - " January 10, 2000 - January 29, 2000
- " Survival Voltages
  - October 19, 1999

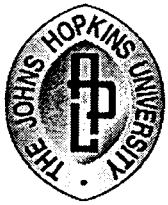

# *TIMED*

*Thermosphere Ionosphere Mesosphere Energetics Dynamics  
Flight Operations Review*

---

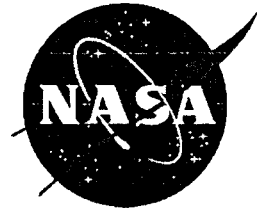

## APL Ground Station RF Compatibility

- Used spacecraft and APL ground station RF system except for the 60' dish for nearly all simulations
- Radiation to/from spacecraft to/from APL dish via rooftop antenna
  - August 1999
  - Command and telemetry





# TIMED

*Thermosphere Ionosphere Mesosphere Energetics Dynamics  
Flight Operations Review*

---



## USN RF Compatibility

- Telemetry Test
  - July 1999
  - TLM only
  - Found a 5dB difference in link margin between theoretical and actual
- Command and Telemetry Test
  - December 1-3, 1999
  - Still had difference in TLM

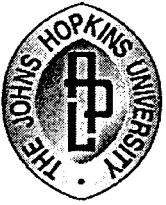

# TIMED

*Thermosphere Ionosphere Mesosphere Energetics Dynamics  
Flight Operations Review*

---



## USN RF Compatibility (con't)

- Re-test TLM
  - October 19-20, 2000
  - Difference in link margin was accounted for
- Reports
  - USN Document # 167 Revision A, December 1999
  - USN Document Number 142, Revision B, October 1999
  - USN Document # 140 Revision A, January 1999
- Further Tests
  - End-to-End tests in November or December
  - Support for Mission Simulations in December



# *TIMED*

*Thermosphere Ionosphere Mesosphere Energetics Dynamics  
Flight Operations Review*

---



## TDRSS Compatibility

- „ Radiation test with actual constellation
  - TLM only
  - December 1999
- „ Network test with data center
  - November 1, 2000
  - November 20, 2000
- „ TIMED MOC reviewed by their Security Office to be in compliance to their requirements

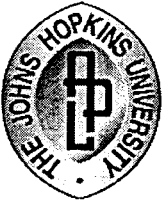

# *TIMED*

*Thermosphere Ionosphere Mesosphere Energetics Dynamics  
Flight Operations Review*

---

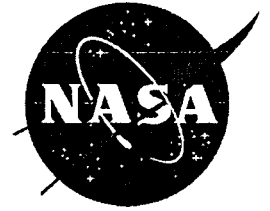

## TDRSS Compatibility (con't)

- TDRSS received data is not processed through the MOC and MDC through normal methods
  - Network Security driven
  - Custom configuration, still uses MOC software
  - Isolated



# *TIMED*

*Thermosphere Ionosphere Mesosphere Energetics Dynamics  
Flight Operations Review*

---



## Mission Simulation List

- " 96/72 Hour
  - Routine Operations
- " Beta 90
  - SEE Operations
- " Event Driven
  - Spacecraft Performance Test
  - Yaw Maneuver



# *TIMED*

*Thermosphere Ionosphere Mesosphere Energetics Dynamics  
Flight Operations Review*

---



## Mission Simulation List (con't)

- „ EOPs / Dress-rehearsal
  - Countdown/Launch
    - „ through APL contacts (first 12 hours)
    - „ through GNS Navigation mode (first 20 hours)
  - SABER cover release
  - SEE / TIDI contact timing
  - L13/L14 Pyro and Cover Release
  - SABER calibration maneuvers

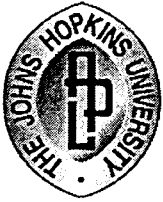

# *TIMED*

*Thermosphere Ionosphere Mesosphere Energetics Dynamics  
Flight Operations Review*

---

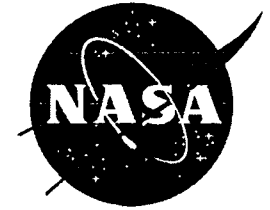

## 96/72 Hour Test

- „ Concurrent with TIDI Beta 45 Test
- „ First done in TV
  - January 17, 2000
  - March 1, 2000 (72 Hr)
  - August 28, 2000
  - October 23, 2000 (MSX orbit, could not be used for TIDI)
- „ Primary Purpose - Training
  - Advanced and Daily Planning
  - Conduct Contacts



# *TIMED*

*Thermosphere Ionosphere Mesosphere Energetics Dynamics  
Flight Operations Review*

---

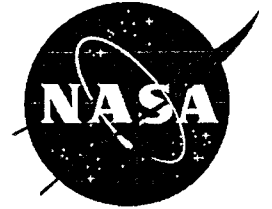

## 96/72 Hour Test (con't)

- “ Tests spacecraft, ground system, procedures, and personnel for an extended period
  - Verifies routine autonomy
  - Tests GNS long term data products
  - Tests Data flow from spacecraft through MDC to MOC
- “ Post-Test Engineering analysis





# *TIMED*

*Thermosphere Ionosphere Mesosphere Energetics Dynamics  
Flight Operations Review*

---

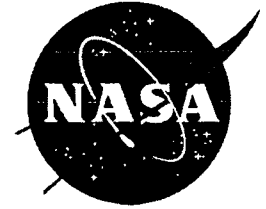

## EOPs

### • Launch to APL Contacts

- August 11, 1999, September 24, 1999, October 18, 1999, October 20, 1999, December 1, 1999, January 11, 2000, August 18, 2000, October 3, 2000, October 4, 2000, October 5, 2000, October 18, 2000
- Rehearses timelines, personal, and spacecraft from launch to APL cluster
- Simulate all contacts through APL ground station
- Use test battery for assessment of DOD on several tests

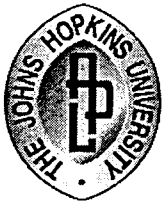

# *TIMED*

*Thermosphere Ionosphere Mesosphere Energetics Dynamics  
Flight Operations Review*

---



## EOPs (cont)

- SABER cover release
  - February 26, 2000, March 6, 2000, August 23, 2000
  - Tests maneuver in spacecraft
  - Tests contact timelines
  - Verifies SABER's TLM



# *TIMED*

*Thermosphere Ionosphere Mesosphere Energetics Dynamics  
Flight Operations Review*

---

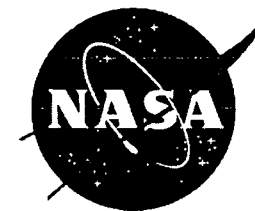

## EOPS (con't)

- SEE / TIDI contact timelines
  - January 2000, September, 2000, October 2000
  - Compress many day's contacts into 2 or 3 8 hour days
  - Tests SEE's and TIDI's timelines

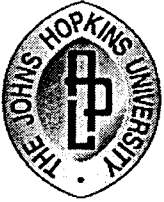

# TIMED

*Thermosphere Ionosphere Mesosphere Energetics Dynamics  
Flight Operations Review*

---



## EOPS (con't)

- " L13/L14 Pyro and Cover Release
  - August 9, 1999, September 8, 2000
  - Tests Timelines and contacts for TIDI and GUVI cover releases
- " SABER calibration maneuvers
  - August 11, 1999, August 13, 1999, September 11, 2000
  - Tests maneuvers for SABER calibrations

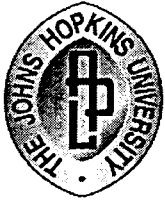

# *TIMED*

*Thermosphere Ionosphere Mesosphere Energetics Dynamics  
Flight Operations Review*

---



## Future Simulations

- " 96/72 Hour
  - November 2000, Launch Site
- " EOPS
  - Countdown to GNS Nav Mode
  - December
- " Contingency Checkout
  - December 2000 and January 2001

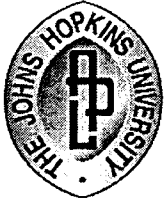

# *TIMED*

*Thermosphere Ionosphere Mesosphere Energetics Dynamics  
Flight Operations Review*

---

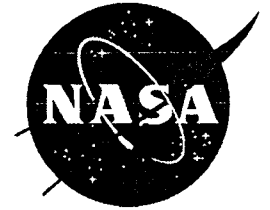

## Launch Site Tests

- " Spacecraft Performance
- " Countdown / Dress Rehearsal
- " EOPs Separation Simulation
- " Mission Operations Simulations
  - 96/72 Hour

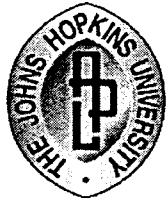

# *TIMED*

*Thermosphere Ionosphere Mesosphere Energetics Dynamics  
Flight Operations Review*

---



## Pad Tests

- " Abbreviated Functional
- " Load /Dumps of processors
  - G&C Parameters
  - GNS Parameters
  - Autonomy
  - Macros
  - Time Tags



# TIMED

*Thermosphere Ionosphere Mesosphere Energetics Dynamics  
Flight Operations Review*

---



## Simulated Anomalies

- „ Negative Acquisition \*
- „ Blind Acquisition \*
- „ AIU Switch \*
- „ Wheel Failure \*
- „ Safe Mode Recovery \*

\* Anomalies from both planned test objectives or unplanned simulator induced



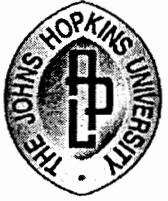

# ***TIMED***

*Thermosphere Ionosphere Mesosphere Energetics Dynamics  
Flight Operations Review*

---



## Simulated Anomalies (con't)

- " Soft and Hard LVSS \*
- " GNS Contingency Procedures
- " C&DH Contingency Procedures
- " G&C Contingency Procedures
- " Additional anomaly testing as time allows on spacecraft or TOPS

\* Anomalies from both planned test objectives or unplanned simulator induced



# ***TIMED***

*Thermosphere • Ionosphere • Mesosphere • Energetics and Dynamics  
Flight Operations Review*

---



# Mission Operations Readiness

William P. Knopf  
JHU/APL  
(443) 778-6416  
william.knopf@jhuapl.edu



# *TIMED*

*Thermosphere • Ionosphere • Mesosphere • Energetics and Dynamics  
Flight Operations Review*

---



## Mission Operations Readiness Status

- This presentation addresses the operational capabilities required to support the on-orbit TIMED mission
- Mission Operations readiness demonstrated through extensive testing of the Operations System with the spacecraft



# *TIMED*

*Thermosphere • Ionosphere • Mesosphere • Energetics and Dynamics  
Flight Operations Review*

---



## Mission Operations Readiness Status

- Operational readiness of the following mission components will be presented
  - Facilities
  - Teams
  - Procedures



# *TIMED*

*Thermosphere • Ionosphere • Mesosphere • Energetics and Dynamics  
Flight Operations Review*

---



## Mission Readiness - Facilities

- Ground Stations/Tracking Facilities
  - APL Satellite Control Facility
    - Operational
  - Universal Space Network
    - Final RF compatibility test (11/14-16)
    - Operability test through mission simulation (12/2000)
  - TDRSS
    - Final interface tests (11/21)



# TIMED

*Thermosphere • Ionosphere • Mesosphere • Energetics and Dynamics  
Flight Operations Review*

---



## Mission Readiness – Facilities (cont.)

- Mission Operations Center (MOC)
  - Hardware
    - Operational
  - Software
    - Rewrite of spacecraft processor load software nearing completion
      - Previous software useable
    - All other software operational
  - Network
    - Firewall modifications per new APL network security directive in process (12/31)



# TIMED

*Thermosphere • Ionosphere • Mesosphere • Energetics and Dynamics  
Flight Operations Review*

---



## Mission Readiness – Facilities (cont.)

- Mission Data Center (MDC)
  - Hardware
    - Operational pending computer upgrade to improve throughput (11/7)
  - Software
    - Real-time telemetry and archiving functions operational
    - As-Run and Planned Timeline generation software in development (scheduled completion: 12/31)



# TIMED

*Thermosphere • Ionosphere • Mesosphere • Energetics and Dynamics  
Flight Operations Review*

---

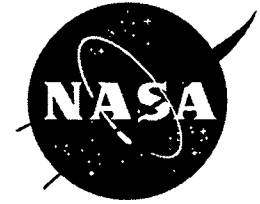

## Mission Readiness – Facilities (cont.)

- Payload Operations Centers (POCs)
  - Test POCs
    - Operational
  - Flight POCs
    - Operational

### Note:

- Operational readiness status pertains to the abilities of the MOC and MDC to support instrument operations
- This is not a measure of POC readiness itself (to be provided by individual instrument teams)





# TIMED

*Thermosphere • Ionosphere • Mesosphere • Energetics and Dynamics  
Flight Operations Review*

---



## Mission Readiness – Personnel

- Mission Operations Team (MOT):
  - Six member MOT is ready for launch
  - Four of the six team members are extensively trained to support TIMED spacecraft operations
    - Participated in all previous subsystem and spacecraft testing
    - Planned, implemented and conducted all mission simulations
  - Remaining two team members have ample operations experience and are currently being trained to support TIMED-specific spacecraft operations



# ***TIMED***

*Thermosphere • Ionosphere • Mesosphere • Energetics and Dynamics  
Flight Operations Review*

---



## Mission Readiness – Personnel (cont)

- Spacecraft Engineering Team
  - Considered as members of the “Extended MOT”
  - Participated in launch and early operations testing
  - Ready for mission support
  - Available thereafter on an on-call basis
- Ground System Team
  - Ready for mission support



# ***TIMED***

*Thermosphere • Ionosphere • Mesosphere • Energetics and Dynamics  
Flight Operations Review*

---



## Mission Readiness – Procedures

- Mission Operations Handbook
  - Primary source of information for all routine operations
  - Over 50% in final form
  - Remainder is in draft form
    - Sections are being finalized after thorough spacecraft testing has been performed using prototype procedures
- Spacecraft Contingency Procedures
  - Readiness discussed in S/C Contingency Procedure presentation



# ***TIMED***

*Thermosphere • Ionosphere • Mesosphere • Energetics and Dynamics  
Flight Operations Review*

---



## Mission Readiness – Procedures (cont)

- Spacecraft Performance Assessment Guide
  - Complete and in use
- Autonomy Rules Handbook
  - Draft complete and in use
- Configuration Management Procedures
  - Phase 1 implemented
  - Phase 2 as described in MOR #2 presentation
    - Documentation in process
    - Implementation underway



# ***TIMED***

*Thermosphere • Ionosphere • Mesosphere • Energetics and Dynamics  
Flight Operations Review*

---

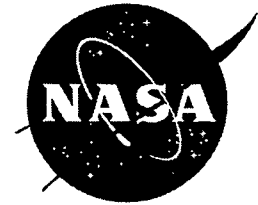

## Early Operations Contact Support

Richard Dragonette



# ***TIMED***

*Thermosphere • Ionosphere • Mesosphere • Energetics and Dynamics  
Flight Operations Review*

---



## Contact Support - Overview

- APL
- USN
  - Kiruna, North Pole, Hawaii
- HBK
- TDRSS



# ***TIMED***

*Thermosphere • Ionosphere • Mesosphere • Energetics and Dynamics  
Flight Operations Review*

---



## Contact Support - APL

- 4 MBPS primary SSR data downlink station
- Both APL contact clusters supported through early ops period (28 days)
- After day 7, APL will be used for most objectives with additional USN support required for specific objectives.



# TIMED

*Thermosphere • Ionosphere • Mesosphere • Energetics and Dynamics  
Flight Operations Review*

---



## Contact Support - USN

- Using 3 stations:
  - Hawaii
  - North Pole
  - Kiruna
- Command uplink at all stations
- 4 MBPS downlink at North Pole and Kiruna during early ops
- 10 KBPS downlink at all three stations





# ***TIMED***

*Thermosphere • Ionosphere • Mesosphere • Energetics and Dynamics  
Flight Operations Review*

---



## Contact Support - Kiruna

- Necessary for the first days on orbit to configure the spacecraft for nadir attitude
- 10 KBPS downlink required for the first day, 4 MBPS once nadir attitude achieved
- Command uplink required
- After the first few days, Kiruna will be used only when specific objectives require the site
  - solar geometry
  - verification of a cover release



# *TIMED*

*Thermosphere • Ionosphere • Mesosphere • Energetics and Dynamics  
Flight Operations Review*

---



## Contact Support - North Pole

- Primary USN site used after first few days on orbit for early operations and normal operations
- North Pole Contacts desired between APL clusters through the first week of early ops
- 10 KBPS downlink required for the first day, 4 MBPS once nadir attitude achieved
- Command uplink required



# ***TIMED***

*Thermosphere • Ionosphere • Mesosphere • Energetics and Dynamics  
Flight Operations Review*

---



## Contact Support - USN Hawaii

- Hawaii will be used during the first 3 days, and for the SABER cover release
  - provides a real-time link to the spacecraft when the cover release command is sent
- May be used for SEE checkout events if the solar geometry requires it
- May be required for contingencies
- 10 KBPS downlink and command uplink only



# ***TIMED***

*Thermosphere • Ionosphere • Mesosphere • Energetics and Dynamics  
Flight Operations Review*

---



## Contact Support - HBK

- Only desired during the first orbit after separation to confirm separation sequence is proceeding
- 10 KBPS telemetry link only
- Probably cannot command through HBK
- No support required after first rev



# ***TIMED***

*Thermosphere • Ionosphere • Mesosphere • Energetics and Dynamics  
Flight Operations Review*

---



## Contact Support TDRSS

- Desired from separation until separation + 2:30
- Spacecraft downlink @ 5 KBPS rate
  - Housekeeping telemetry only
- Command uplink possible
- Will be interrupted during USN contacts during the first 2:30 after separation
  - During USN contacts spacecraft switches to 10 KBPS downlink



# TIMED

*Thermosphere • Ionosphere • Mesosphere • Energetics and Dynamics  
Flight Operations Review*



## Very Early Ops Contact Timeline

Contact Number	Site	Time After Separation (hh:mm:ss)
1	HBK	0:29:31
2	Kiruna	0:57:33
3	North Pole	1:10:04
4	Hawaii	1:20:21
5	Kiruna	2:32:41
6	Kiruna	4:10:29
7	Kiruna	5:49:42
9	Kiruna	7:29:46
10	APL	8:53:26
11	Kiruna	10:48:02
12	North Pole	13:51:37
8th contact deleted when updated obscura mask incorporated into planning software		



# TIMED

*Thermosphere • Ionosphere • Mesosphere • Energetics and Dynamics  
Flight Operations Review*



## Very Early Ops - Available Contacts

Station	Duration (secs)	Time After Separation (hh:mm:ss)
May_TIMED_insert-To-HBK	650.897	0:29:31
May_TIMED_insert-To-Kiruna	429.189	0:56:51
May_TIMED_insert-To-North_Pole_AL	350.994	1:10:32
May_TIMED_insert-To-Kona	620.928	1:20:39
May_TIMED_insert-To-Kiruna	625.004	2:32:58
May_TIMED_insert-To-Kiruna	663.405	4:11:17
May_TIMED_insert-To-Kiruna	645.951	5:50:46
May_TIMED_insert-To-Kiruna	640.724	7:30:29
May_TIMED_insert-To-APL	655.593	8:53:29
May_TIMED_insert-To-Kiruna	660.841	9:09:49
May_TIMED_insert-To-APL	323.844	10:35:49
May_TIMED_insert-To-Kiruna	651.125	10:48:48
May_TIMED_insert-To-North_Pole_AL	360.05	12:16:23
May_TIMED_insert-To-Kiruna	527.674	12:27:55
May_TIMED_insert-To-HBK	603.21	12:52:25
May_TIMED_insert-To-Kona	649.021	13:39:14
May_TIMED_insert-To-North_Pole_AL	622.119	13:51:51



# ***TIMED***

*Thermosphere • Ionosphere • Mesosphere • Energetics and Dynamics  
Flight Operations Review*

---



## Launch Critical Facilities

William P. Knopf

JHU/APL

(443) 778-6416

[william.knopf@jhuapl.edu](mailto:william.knopf@jhuapl.edu)





# TIMED

*Thermosphere • Ionosphere • Mesosphere • Energetics and Dynamics  
Flight Operations Review*

---



## Launch Critical Facilities

- Ground Stations
  - NASA
    - TDRSS/White Sands
      - Command Uplink
      - 5 kbps telemetry downlink
  - Universal Space Network
    - Kiruna
      - Command uplink
      - 10 kbps, 2Mbps telemetry downlink
        - » 4 Mbps is expected, but is not mandatory



# *TIMED*

*Thermosphere • Ionosphere • Mesosphere • Energetics and Dynamics  
Flight Operations Review*

---



## Launch Critical Facilities (cont.)

- APL Mission Operations Center
  - Command workstation (inner firewall)
  - Telemetry workstation (inner firewall)
  - Network to TDRSS
  - Network to USN
  - Network to MDC
- APL Mission Data Center
  - Network to ground station interfaces
  - Telemetry archive



# *TIMED*

*Thermosphere • Ionosphere • Mesosphere • Energetics and Dynamics  
Flight Operations Review*

---



## Launch Critical Facilities (cont.)

- Go/NoGo Criteria
  - Mandatory
  - Required
  - Desired
- Go/NoGo Matrix has been prepared and is in review



# *TIMED*

*Thermosphere • Ionosphere • Mesosphere • Energetics and Dynamics  
Flight Operations Review*

---



## Personnel Assignments

William P. Knopf  
JHU/APL  
(443) 778-6416  
william.knopf@jhuapl.edu



# ***TIMED***

*Thermosphere • Ionosphere • Mesosphere • Energetics and Dynamics  
Flight Operations Review*

---



## **Personnel Assignments**

- **Mission Operations Manager**
  - William Knopf
- **Mission Operations Manager Emeritus**
  - Robert Nordeen
- **Ground System Engineer**
  - Elliot Rodberg
- **Autonomy System Engineer**
  - Raymond Harvey
- **Software System Engineer**
  - Martha Chu



# **TIMED**

*Thermosphere • Ionosphere • Mesosphere • Energetics and Dynamics  
Flight Operations Review*

---



## **Personnel Assignments (cont)**

- **Mission Operations Spacecraft Specialists**
  - C&DH
    - Paul Boie (Primary)
    - William Knopf (Alternate)
  - GNS
    - Richard Dragonette (Primary)
    - George Chiu (Alternate)
  - G&C
    - Michael Packard (Primary)
    - Charles Kowal (Alternate)



# ***TIMED***

*Thermosphere • Ionosphere • Mesosphere • Energetics and Dynamics  
Flight Operations Review*

---



## **Personnel Assignments (cont)**

- **Operations Software Maintenance**
  - Real-time Software
    - Patrick Clark (APL Developed S/W)
    - Dennis Whichard (APL Developed S/W)
    - David Steyer (ISI)
  - Planning Software
    - Patrick Clark
    - Henry DeWitt (DeWitt & Associates)
    - William Knopf
  - Assessment Software
    - Dennis Whichard
    - William Knopf



# *TIMED*

*Thermosphere • Ionosphere • Mesosphere • Energetics and Dynamics  
Flight Operations Review*

---



## Personnel Assignments (cont)

- Flight Software
  - C&DH
    - Steven Williams
  - GNS
    - Tom Kusterer
  - AFC
    - Steven Offenbacher
  - AIU
    - Paul Haring





# *TIMED*

*Thermosphere • Ionosphere • Mesosphere • Energetics and Dynamics  
Flight Operations Review*

---



## Personnel Assignments (cont)

- Mission Data Center
  - Paul Lafferty
  - Martha Chu
- System Administration
  - Steven Lundfelt
  - Gabrielle Griffith
- Network Administration
  - Jeffrey Davis
  - Jon Handiboe



# *TIMED*

*Thermosphere • Ionosphere • Mesosphere • Energetics and Dynamics  
Flight Operations Review*

---



## Personnel Locations during LEOPs

- Vandenberg Air Force Base
  - Project Manager (David Grant)
  - Mission System Engineer (David Kusnierkiewicz)
  - Integration and Test Engineer (Stanley Kozuch)
  - Power System (Mike Butler)
  - Test Conductors
    - Vincent Bailey
    - Mark Hill



# TIMED

*Thermosphere • Ionosphere • Mesosphere • Energetics and Dynamics  
Flight Operations Review*

---



## Personnel Locations during LEOPs (cont)

- Mission Operations Center
  - Mission Operations Manager
  - Mission Operations Manager Emeritus
  - Ground System Engineer
  - Autonomy System Engineer
  - Spacecraft Specialists
  - Software Support
  - Mission Data Center Engineer
  - System Administrators
  - Network Administrators



# TIMED

*Thermosphere • Ionosphere • Mesosphere • Energetics and Dynamics  
Flight Operations Review*

---



## Personnel Locations during LEOPs (cont)

- Mission Operations Center (continued)
  - Spacecraft Engineering Team
    - C&DH (S. Williams, R. Redman)
    - GNS (A. Chacos, R. Heins, T. Kusterer, R. DeBolt)
    - G&C (D. Wilson, W. Radford, W. Dellinger)
    - Power (G. Dakermaji, D. Temkin)
    - Thermal (B. Williams, D. Mehoke)
    - RF (C. DeBoy, J. Goldman)
    - I&T (M. Colby, H. Nguyen)



# *TIMED*

*Thermosphere • Ionosphere • Mesosphere • Energetics and Dynamics  
Flight Operations Review*

---



## Personnel Locations during LEOPs (cont)

- APL Ground Station
  - Satellite Control Facility Manager (G. Baer)
  - Ground Station Engineer (S. Gemeny)
  - Ground Station S/W Engineer (H. DeWitt)
  - Antenna Control Engineer (T. Nalepa)



# *TIMED*

*Thermosphere • Ionosphere • Mesosphere • Energetics and Dynamics  
Flight Operations Review*

---



## Personnel Locations during LEOPs (cont)

- USN Ground Stations
  - Manned Engineering Support at Alaska and Hawaii Remote Ground Stations
  - Manned Swedish Space Corp (SSC) Support at Kiruna Ground Station
  - Manned Support at Horsham Network Management Center (NMC)
    - Backup support at Huntington Beach NMC



# TIMED

*Thermosphere • Ionosphere • Mesosphere • Energetics and Dynamics  
Flight Operations Review*

---



## Personnel Locations during LEOPs (cont)

- MOT Staffing during LEOPs
  - A minimum of two Mission Operations Team members will staff the MOC from the T-10 hour countdown through on-orbit operations for three days
  - After launch + 72 hours, Mission Operations staffing will transition to a two shift per day operation to cover all APL contacts



# TIMED

*Thermosphere • Ionosphere • Mesosphere • Energetics and Dynamics  
Flight Operations Review*

---



## Personnel Locations during LEOPs (cont)

- MOT Staffing post LEOPs
  - L+28 days begins normal operations phase
  - MOT to staff daytime APL contacts only
    - Two person control team
    - Staffing per MOR-2 Presentation





# *TIMED*

*Thermosphere • Ionosphere • Mesosphere • Energetics and Dynamics  
Flight Operations Review*

---



## On-orbit Mission Operations Team

- Three teams of two spacecraft operators
  - Spacecraft Control Team
    - Two teams conduct daily operations (7 days/week)
    - Four 10 hour days on, 3 days off
  - Planning and Analysis Team
    - Supports advanced planning and comprehensive performance assessment activities
    - Five 8 hour days, Monday through Friday
  - Teams rotate positions every four weeks
- Two person ground system support team
  - Software maintenance support
  - System administration and management
  - General ground system maintenance



# TIMED

*Thermosphere • Ionosphere • Mesosphere • Energetics and Dynamics  
Flight Operations Review*



## MOT Support Scheduling

- Early on-orbit operations phase (first month)
  - 24-hour per day support until spacecraft control well characterized (expected within first week)
    - Mission Operations Team augmented by Spacecraft Bus Engineering Team and Integration and Test Team
  - The two daily APL contact clusters (two shifts per day) will be supported thereafter
- Operations phase following the early operations phase (the next two years)
  - Daytime contact support only (support the APL ground station daytime 2-3 contact cluster)
  - On-call for emergency operations
  - Possible non-attended nighttime operations



# *TIMED*

*Thermosphere • Ionosphere • Mesosphere • Energetics and Dynamics  
Flight Operations Review*

---

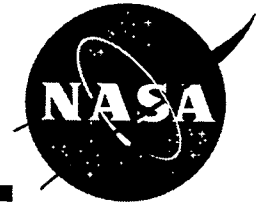

## RFA Status From Previous Mission Operations Reviews

William P. Knopf  
JHU/APL  
(443) 778-6416  
[william.knopf@jhuapl.edu](mailto:william.knopf@jhuapl.edu)



# TIMED

*Thermosphere • Ionosphere • Mesosphere • Energetics and Dynamics  
Flight Operations Review*

---



## RFA Status – MOR #1

- RFA #1      Provide capability to clear instrument staging and uplink command queues individually  
                 -Capability has been provided
- RFA #2      Provide capability to permit parameters to be transferred as part of command macro calls  
                 -No value added in this implementation; capability not provided
- RFA #3      Acquire MOT staff to perform specific functions rather than advertised concept of complete interchangeability  
                 -Small MOT does not permit specialization



# TIMED

*Thermosphere • Ionosphere • Mesosphere • Energetics and Dynamics  
Flight Operations Review*

---



## RFA Status – MOR #1 (continued)

RFA #4      Maintain all mission operations related documentation on-line

-Has been implemented

RFA #5      Insufficient margin when assuming an operations concept of only one contact per day

-Although a single contact per day is the design concept (and feasible) we intend to schedule all daytime contacts every day

RFA #6      Ground system requirements not presented

-Requirements do exist and provided at previous reviews



# *TIMED*

*Thermosphere • Ionosphere • Mesosphere • Energetics and Dynamics*

*Flight Operations Review*

---



## RFA Status – MOR #1 (continued)

- RFA #7      Orbital drag calculations may need to be updated  
                  -These are periodically updated when new  
                  information becomes available









