



MMS ASPOC

Science Data Products Guide

Doc ID MMS-ASP-IWF-TN-0042
Issue 2.0
Issue Date 25 February 2016

Prepared by Harald Jeszenszky, PM (harald.jeszenszky@oeaw.ac.at)

Verified by Gunter Laky, QA (gunter.laky@oeaw.ac.at)

Approved by Rumi Nakamura, PI (rumi.nakamura@oeaw.ac.at)

Institut für Weltraumforschung
Österreichische Akademie der Wissenschaften
Schmiedlstraße 6, 8042 Graz
Tel +43 (316) 4120-400
Fax +43 (316) 4120-490
Email office.iwf@oeaw.ac.at

Change record

Issue	Date	Author	Modifications
Draft.0	Mar 15, 2013	HaJes	Initial version
Draft.1	Sep 01, 2013	HaJes	Updated section 4
Draft.2	Oct 27, 2014	HaJes	All
1.0	Sep 01, 2015	HaJes	All
2.0	Feb 25, 2016	HaJes	Adapted for compliance with MMS CDF Format Guide v1.8

Contents

1	Introduction	5
1.1	Scope	5
1.2	Acronyms	5
1.3	Documents	5
1.3.1	Applicable Documents	5
1.3.2	Reference Documents	5
2	Instrument Description	6
2.1	Overview	6
2.2	Science Background	7
2.3	Level 1/2 Requirements	8
2.3.1	Science Data System	8
2.3.2	Interfaces to/from SOC (Data Processing)	8
2.4	Instrument Characteristics	9
2.4.1	Block Diagram of ASPOC	10
2.4.2	Electronics	11
2.4.3	Other Subsystems	11
2.4.4	Spacecraft Accomodation	12
2.4.5	Operating Modes	13
3	General Conventions	16
3.1	Formats	16
3.2	Standards	16
3.3	Production Procedures	16
3.3.1	Usage of Data Production Software	16
3.4	Quality Control Procedures	16
3.5	Data Delivery Procedures	17
4	ASPOC Data Products	18
4.1	Overview	18
4.1.1	L1b/SITL Data Products	18
4.1.2	L2 Data Products	18
4.2	Quicklook Data Products	19
4.2.1	File Naming	19
4.2.2	Plot Parameters	19
4.3	Level-1b/SITL Data Products	21
4.3.1	File Naming	21
4.3.2	Beam File Structure	21
4.3.3	Stat File Structure	21
4.4	Level-2 Data Products	23
4.4.1	File Naming	23
4.4.2	File Structure	23
5	Data Analysis and Visualization	25
5.1	Autoplot (http://autoplot.org/)	25

5.2	CDAWlib (http://spdf.gsfc.nasa.gov/CDAWlib.html).....	25
5.3	Qtran (http://www.sp.ph.ic.ac.uk/csc-web/Qtran/).....	25
A	SAMPLE CDF SKELETON FILES.....	26
A.1.	L1B Beam Data CDF Skeleton File.....	26
A.2.	L1B Status Data CDF Skeleton File	33
A.3.	L2 Data CDF Skeleton File	43

List of Figures

Figure 1: Electron spectogram, DSP TC-1 PEACE	7
Figure 2: Instrument picture	10
Figure 3: ASPOC overall block diagram	10
Figure 4: Electronics box.....	11
Figure 5: Cross-section of an emitter module.....	12
Figure 6: Aspoc accomodation	13
Figure 7: Operating modes	14
Figure 8: Sample quicklook plot.....	20
Figure 9: Sample ASPOC L1b data plot	25

List of Tables

Table 1: L1B Beam Data CDF Skeleton File	32
Table 2: L1B Status Data CDF Skeleton File	42
Table 3: L2 Data CDF Skeleton File	50

1 Introduction

1.1 Scope

The Data Products Guide (DPG) contains the detailed description and specification of all Level 1/2 data products generated by the Science Data Center (SDC) in collaboration with the ASPOC instrument team. The ASPOC ITF provides SDC with data processing software to produce Level 1, Level 2 and Quicklook data products. The ASPOC team is led by the Space Research Institute (IWF) of the Austrian Academy of Sciences located in Graz/Austria. The DPG is intended as a fully self-contained guide.

The purpose of the team activity for ASPOC is to provide a database with full information on the data produced by the ASPOC instrument and on its technical status throughout the mission. ASPOC is an active experiment that modifies the environment of the spacecraft by an energetic ion beam in order to improve measurements by other instruments on board. These include measurements obtained by FPI, HPCA and FIELDS (ADP and SDP). Detailed knowledge about the operation of ASPOC, its operational status, and of eventual anomalies, is critical for the interpretation of the measurements affected by ASPOC. Short-time variations of the ion beam emitted by ASPOC could be important for a full understanding of plasma, electric field and spacecraft potential data. The operational modes of ASPOC define the method to control the ion beam current. Each method has its own effect on the ion beam.

1.2 Acronyms

ASPOC..... Active Spacecraft Potential Control
 CDF Common Data Format
 DCC DC Converter
 DPG Data Products Guide
 DPU Data Processing Unit
 ITF..... Instrument Team Facility
 SDC Science Data Center
 SITL Scientist In The Loop

1.3 Documents

1.3.1 Applicable Documents

ID	Title	Doc ID	Issue	Date
AD1	MMS SDC Developer Guide		1.9	04/11/14
AD2	MMS CDF File Format Guide		1.8	01/19/16

1.3.2 Reference Documents

ID	Title	Doc ID	Issue	Date
RD1	MMS ASPOC User Manual	MMS-ASP-IWF-UM-0001	1.0	09/01/15
RD2	CDF User's Guide		3.6	02/20/15

2 Instrument Description

2.1 Overview

ASPOC is a heritage-design instrument that was originally flown - among others - on ESA's Cluster spacecraft. The primary objective of active spacecraft potential control (ASPOC) is to insure the effective and complete measurement of the ambient plasma distribution functions. The ASPOC instrument emits a beam of positive indium ions at energies of order 4 to 12 keV and currents of up to $\sim 70 \mu\text{A}$ in order to control the electrical potential of the spacecraft. The emission of positive charges from the spacecraft balances the excess of charge accumulating on the vehicle from interactions with the environment. For the case of primary concern here, where photo-emission of electrons drives the spacecraft potential positive relative to the plasma potential, it is necessary to emit positive ions. By adjusting the positive emission current, the spacecraft potential can thus be adjusted to near zero value. Hence, the output of the instrument is an energetic ion beam with known energy and controlled current. By applying currents of several 10's of μA on the MMS spacecraft, the equilibrium potential will in any environment be driven into a regime which is independent of the ambient plasma density, and mainly be governed by the active ion beam current and the properties (mainly current and energy distribution) of the photo-electrons from the spacecraft surface, both of them are constant. As a result, the spacecraft potential will be clamped to a value at which the current of the photo-electrons overcoming the potential barrier around the spacecraft equals the ion beam current. This equilibrium is established at potentials of a few Volts positive, as an inverse function of the ion beam current.

The ion emitters are liquid metal ion sources using indium as charge material. A capillary is mounted in a heated reservoir with the charge material. When high voltage is applied between the capillary and an extractor electrode, the electrostatic stress at the tip of the capillary pulls the liquid metal inside towards the extractor electrode and a cone with a very small diameter is formed so that field evaporation takes place, and an ion beam is formed.

Two ASPOC instruments are installed on each of the four spacecraft and emit ion beams in antiparallel direction for symmetry reasons. Each instrument contains four individual emitters which are operated one at a time, for redundancy reasons and in order to ensure the required lifetime. Two individual ion emitters are contained in one ion emitter "module" and have a common high voltage supply. The indium reservoir and the capillary sitting on top are kept at high voltage. The ion sources are individually and indirectly heated from below by a resistor embedded into a ceramic insulator tube. This scheme enables the source to be heated from a grounded power supply and the tip itself still being kept at high voltage. The selection of the active emitter is made by switching high voltage to one of the emitter modules, and secondly by heating the active emitter. The second emitter in the same module will not ignite as the tip radius of a cold emitter with solid indium is too large for field emission to set in.

The ASPOC unit consists of an electronics box to which two cylindrical modules containing the emitters are attached. Both low and high voltage harness is routed externally between the box and the modules. The modules are mechanically connected to increase the stiffness. On top of the modules there is a plate to which the MLI of the spacecraft is attached. All parts of the units except the top surfaces of the emitter modules are located inside the spacecraft envelope.

2.2 Science Background

The ASPOC ion emitter instruments control the electric potential of the spacecraft with respect to the ambient plasma by emitting a variable current of positive ions. In steady state, a spacecraft will charge to an equilibrium potential where all currents, namely photo-electron current caused by sunlight, plasma currents due to the environmental electrons and ions, secondary electron currents caused by the impact of primary electrons and ions, and the ion current generated by the two ASPOCs compensate so that there is no net transfer of charge between the spacecraft and the environment.

Without active control, spacecraft potentials along the orbit would range from a few volts positive in the solar wind and magnetosheath up to some 10's of Volts in the plasmashet and in the magnetospheric lobes. Plasmashet potentials are expected to lie between the magnetosheath and lobe cases. Small negative potentials are possible in the plasmasphere.

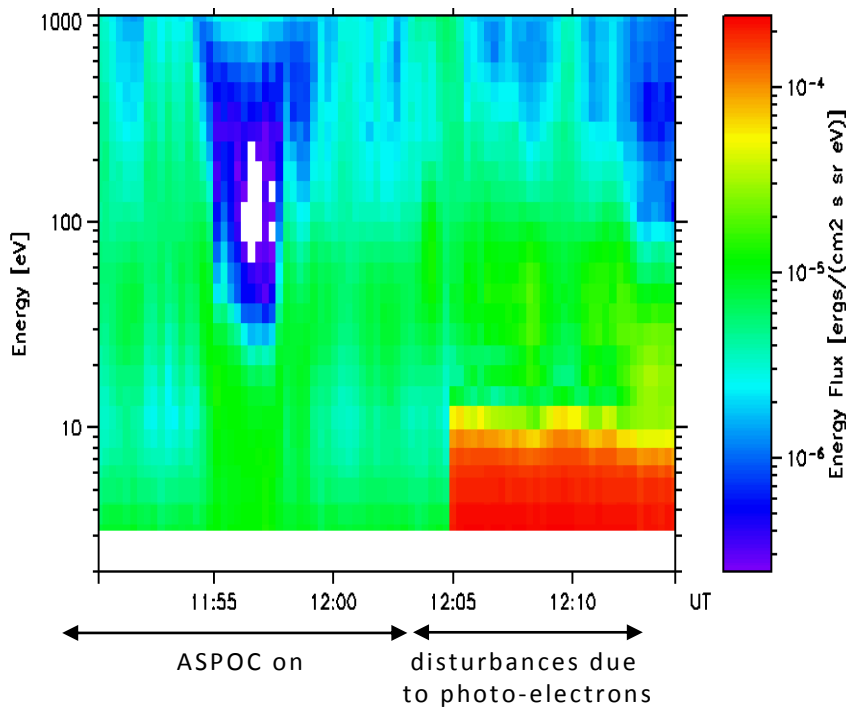

Figure 1: Electron spectrogram, DSP TC-1 PEACE

The primary objective of ASPOC is the reduction of high positive spacecraft potentials to a constant value which is sufficiently low (a few volts) to reduce the above mentioned disturbances significantly. Figure 1 shows the influence of ASPOC on plasma measurements performed at low energy.

Further information on the scientific objectives and about in-orbit results can be found in [###].

2.3 Level 1/2 Requirements

2.3.1 Science Data System

The ASPOC ITF provides SDC with data processing software to produce Level 1, Level 2 and Quicklook data products.

Level 2 products will include combined ASPOC1 and ASPOC2 data:

- ASPOC 1 and 2 are seen as a single virtual instrument
- Time stamps interpolated to round (integer) seconds

The ITF supports the SDC in producing validated Level 2 products

Validation procedure for Level 2 is baselined as follows:

- Validated Level 2 products are re-produced at SDC based on validation parameter input (files) generated at ITF and sent to SDC after inspection of preliminary Level 2 products by the ITF
- Turn-around time 1 week maximum

No Level 3 products are foreseen at present

Provide SDC with access/visualization tools for delivered data products, if necessary

- Data may be visualized by simple line plots, there may not be a need to provide software for this purpose

2.3.2 Interfaces to/from SOC (Data Processing)

Scheduled batch processes:

- ASPOC Level 0 data from SOC
- Temperatures, Main Power currents from SOC
- ASPOC unvalidated Level 2 data from SOC (baseline)
- Level 2 validation information or validated ASPOC Level 2 data to SOC

Access to SOC for maintenance of calibration data base

Access to SOC machine for ASPOC processing and visualization software test and maintenance

Access for retrieval of orbit and other instrument data for science validation

2.4 Instrument Characteristics

The instrument emits positively charged ions (indium) in order to compensate other currents induced by Solar ultra-violet radiation and other effects, and thereby clamps the spacecraft potential to values below about 4 V.

The main functions of ASPOC are:

- Two pairs of Ion emitters. An ion emitter consists of the emitter capillary, the reservoir, and a heater element.
- High voltage supply for two pairs of Ion emitters (0 to 12kV, 0 to 70 μ A)
- Safe mode operation of HV supply with limited output voltage
- Indium heater supply
- Ion emitter current or voltage control loop
- DC/DC converter to generate secondary supply voltages
- DPU to control the supplies, to interface with the CIDP

The ASPOC instrument is configured to carry two emitter modules at the top of the electronics box. Each module contains two individual emitters. The emitter module system consists of the following elements:

- Two emitter modules mounted at the top of the box. Each Module contains two emitters. There is a common high voltage line for both emitters inside a Module.
- Mechanical stiffening rods interconnecting both modules and connecting them through two tilted rods with the top plate of the electronics box
- An MLI flange, which is a plate on which the spacecraft MLI can be attached.
- A system of dry nitrogen purge lines starting with a fitting for the purge line coming from the spacecraft, and leading to the lower parts of both emitter modules.
- External harness: There is low and high voltage harness between the box and each Module.

The main elements of the ASPOC electronics box are:

- Digital Processing Board (DPU): It receives commands from the spacecraft and sends telemetry to the spacecraft. The DPU also controls the HVC through analogue and digital signals. The DPU also controls the selection of filaments in the Modules.
- Low voltage power converter and emitter filament converter board (DCC): It generates all secondary low voltages including the variable voltage for the heater elements (filaments) in each of the four emitters.
- High voltage converter board (HVC): It provides high voltage for the active emitter module, and switches high voltage between the two emitter modules according to signals received from the DPU.



Figure 2: Instrument picture

2.4.1 Block Diagram of ASPOC

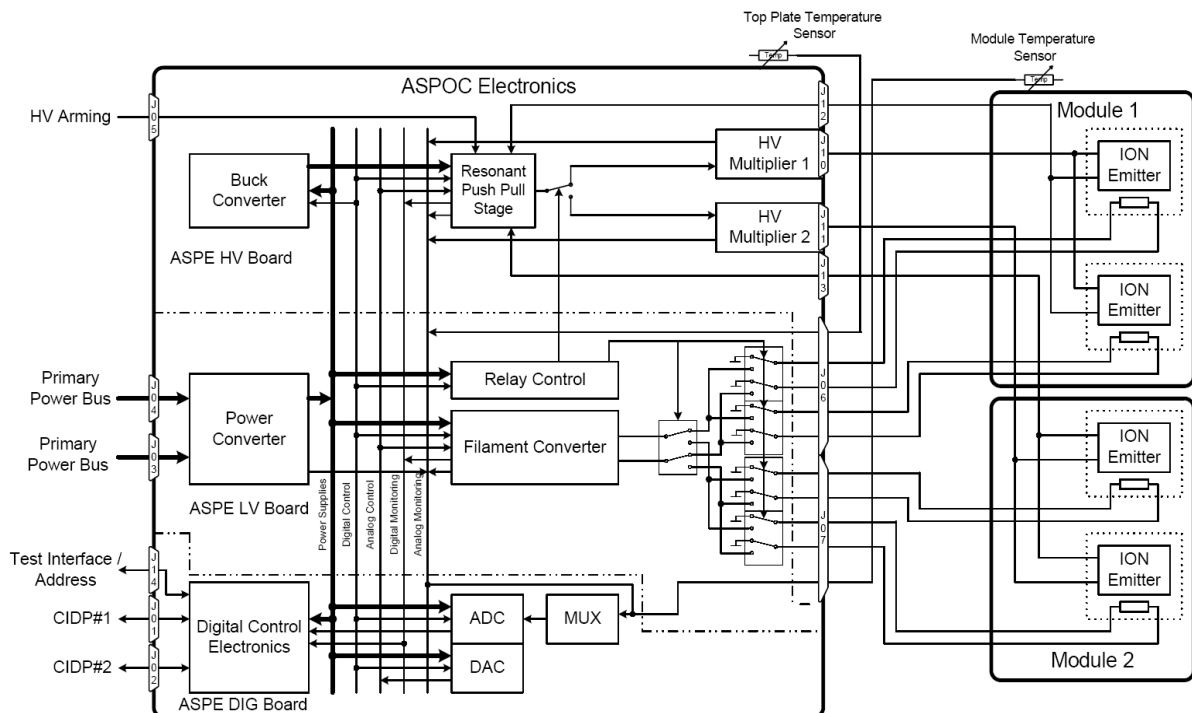

Figure 3: ASPOC overall block diagram

2.4.2 Electronics

The electronics box consists of three stacked frames (one for each printed circuit board). Figure 4 shows the ASPOC Electronics Box.

The top plate of the box is rigid, as it supports several items mounted on top: Two cylinders containing the emitters, stiffening rods for these cylinders, and a purge connector which splits the gas flow to both cylinders.

All harness between the electronics box and the emitters is routed outside the structure. The harness includes low voltage harness for the heater elements and external temperature sensors, and high voltage cables.

At the very top there is a plate to which the spacecraft MLI may be attached easily.

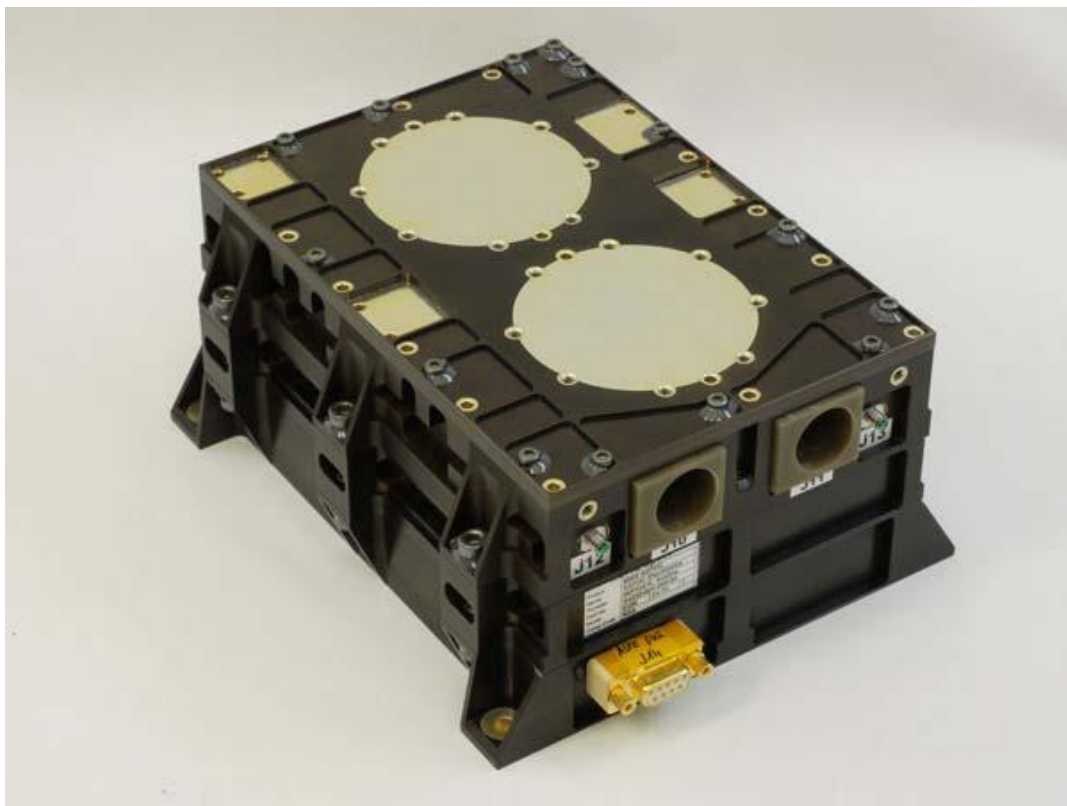

Figure 4: Electronics box

2.4.3 Other Subsystems

The ion emitters are liquid metal ion sources using indium as charge material. Two individual ion emitters are contained in one ion emitter "module" and have a common high voltage supply. The indium reservoir and the reservoir sitting on top are kept at high voltage.

The ion sources are individually and indirectly heated from below by a resistor embedded into a ceramic insulator tube. This scheme enables the source to be heated from a grounded power supply and the tip itself still being kept at high voltage.

The selection of the active emitter is made by switching high voltage to one of the emitter modules, and secondly by heating the active emitter. The second emitter in the same module will not ignite as the tip radius of a cold emitter with solid indium

is too large for field emission to set in. Figure 5 shows a cross-section through an emitter module.

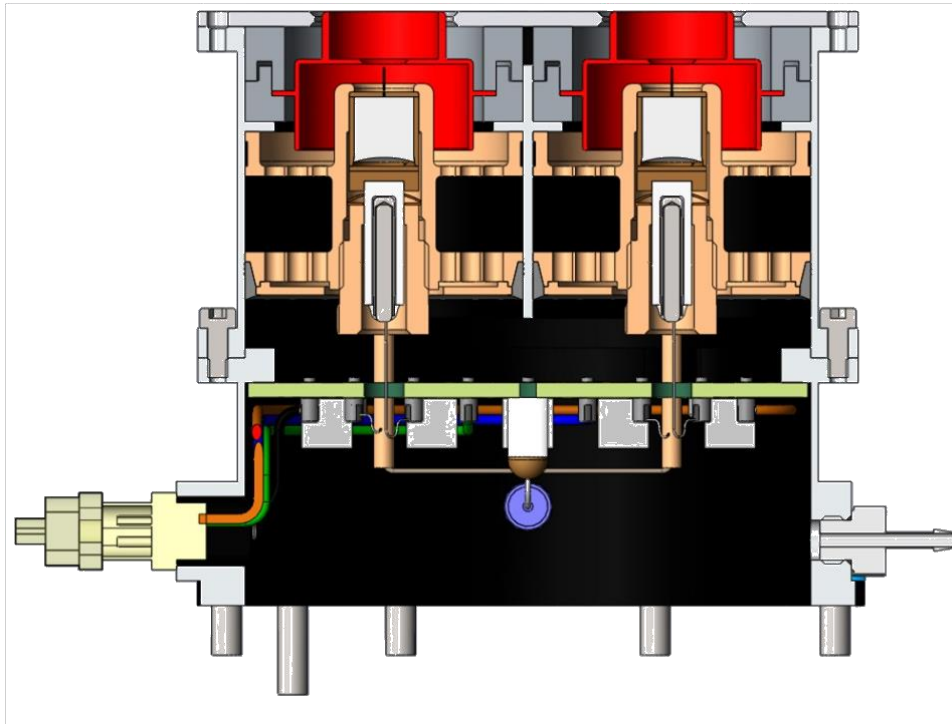

Figure 5: Cross-section of an emitter module

2.4.4 Spacecraft Accomodation

The two ASPOC instruments are mounted at opposite sides of the instrument deck by means of brackets as shown in Figure 6.

The ion beams of the two ASPOC instruments point in antiparallel directions such that the center axis of the ion beam is equidistant to the SDP probes. The only surfaces exposed to space shall be the top plates of the emitter modules. The rest of the instrument is inside the spacecraft envelope or covered by MLI of the spacecraft.

ASPOC Locations in the MMS Zeta Configuration

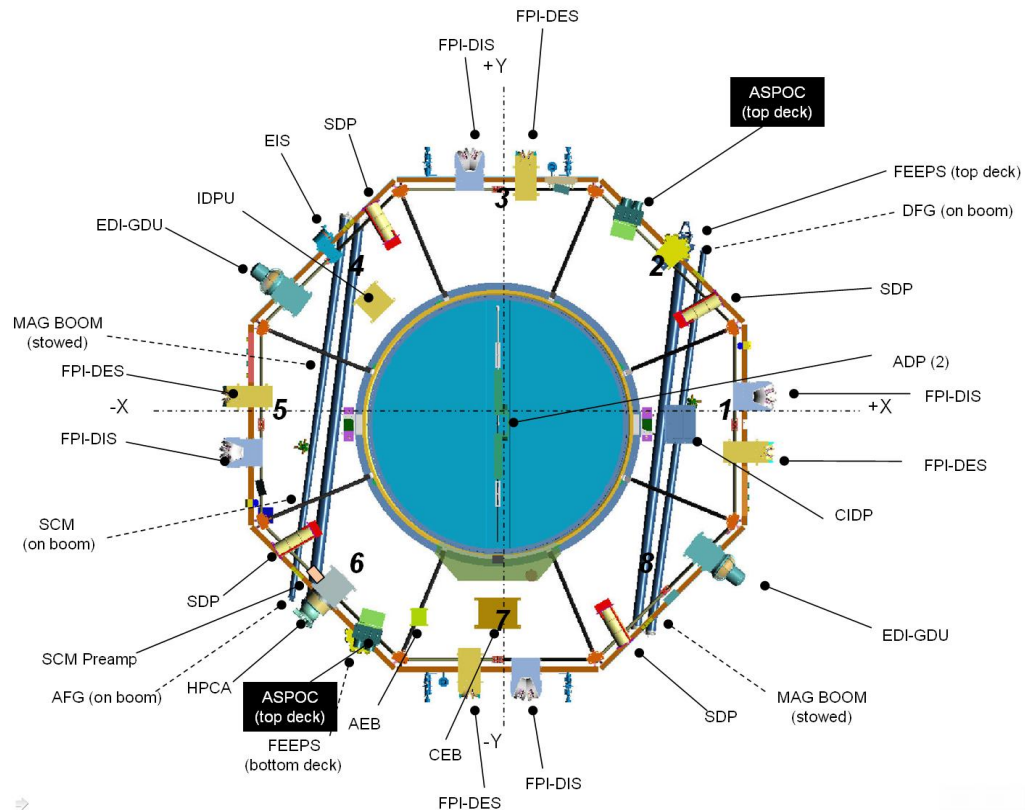

Figure 6: Aspoc accomodation

2.4.5 Operating Modes

There are several state machines in FSW with a small number of operational modes in each.

The most widely used active mode of the instrument will be the constant total current mode (ITOT). It sets a constant output current of the high voltage unit, which includes any losses inside the lens system. Experience has shown that the resulting emission of an almost constant ion current fulfils all requirements for spacecraft potential control in the magnetosphere and the solar wind even without on-board feedback from measurements of the spacecraft potential.

When the fuel save mode option (STOT) is activated, the instrument also listens to the S/C potential message. If the beam is on, and the potential remains below the off-trigger value for more than the trigger delay time, then the instrument switches into hot standby mode. If the beam is off, and the potential remains above the on-trigger value for more than the trigger delay time, then the instrument performs in the same way as in the standard total current mode.

In constant ion current mode (IION) the processor of the instrument reads the monitor of the outgoing beam current and adjusts the output current of the high voltage supply to compensate for any losses in the system.

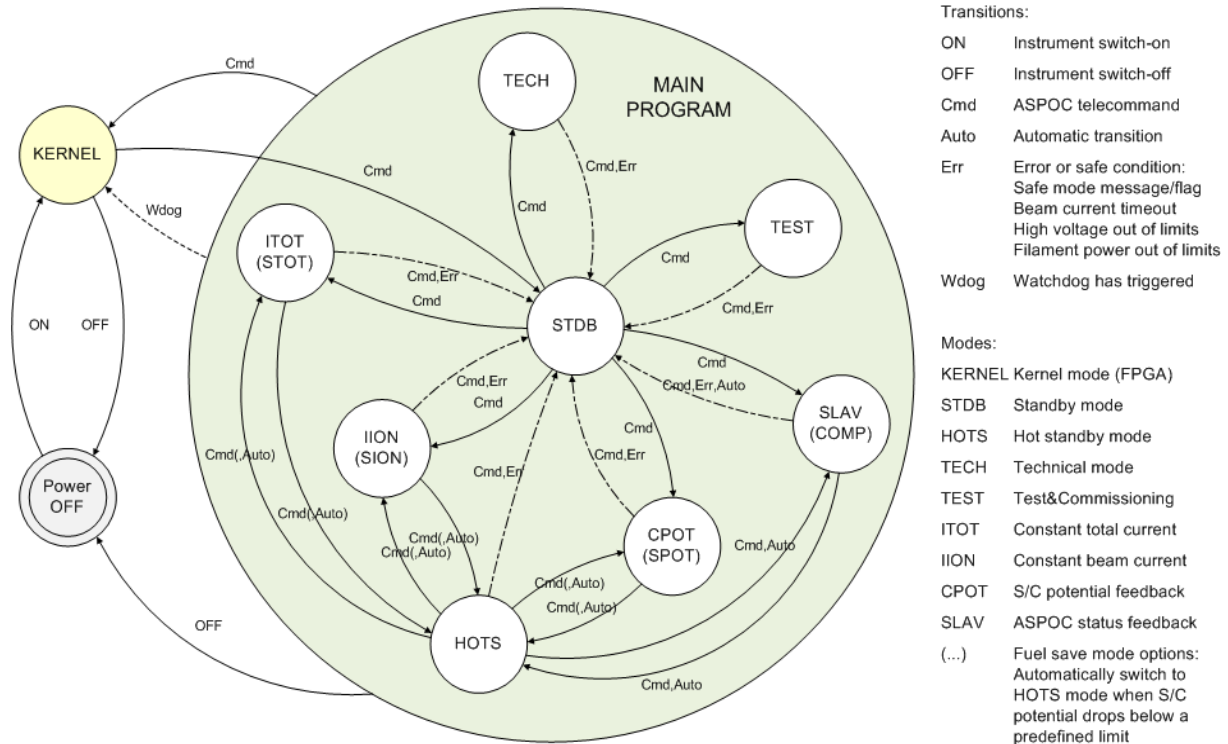

Figure 7: Operating modes

When the fuel save mode option (SION) is activated, the instrument also listens to the S/C potential message. If the beam is on, and the potential remains below the off-trigger value for more than the trigger delay time, then the instrument switches into hot standby mode. If the beam is off, and the potential remains above the on-trigger value for more than the trigger delay time, then the instrument performs in the same way as in the standard ion current mode.

In the so-called feedback mode (CPOT), a measurement of the spacecraft potential is supplied to ASPOC by the FIELDS Instrument and this information is then used to adjust the beam current in order to maintain a constant value of the potential in a closed-loop scheme. The measurements of the spacecraft potential are updated once every second and sent to ASPOC via dedicated messages (CIDP Bent-Pipe Telemetry).

When the fuel save mode option (SPOT) is activated, the beam is on, and the potential remains below the off-trigger value for more than the trigger delay time, then the instrument switches into hot standby mode. If the beam is off, and the potential remains above the on-trigger value for more than the trigger delay time, then the instrument performs in the same way as in the standard feedback mode.

In slave mode (SLAV), the instrument performs a startup as in constant ion current mode. As soon as normal operational status is reached (startup completed), the instrument listens to the beam current and mode information received through the ASPOC status message from the other (master) unit (CIDP Bent-Pipe Telemetry) and follows the master.

When the compensating mode option (COMP) is activated and the beam current of the master is non-zero, the instrument uses a set value for its own control loop twice the set value of the beam current minus the beam current of the master. In this way the sum of both ion beam currents stays at 2 times the value of the beam current commanded to the compensating slave.

In standby mode (STDB) both the emitters and their heaters are turned off. The standby mode is also the safe mode of the instrument, to which it returns autonomously under certain error conditions. The transition into standby mode also clears all error flags and the emitter selection, and disables high voltage and the heaters.

In order to reduce the time before emission starts, a hot standby mode (HOTS) keeps the indium in a liquid state. This mode can be used to interrupt the ion emission by command, without change of modes or emitters before and after the break. The re-ignition time is reduced to the time required to sweep the high voltage (less than a minute).

A test and commissioning mode (TEST) varies the total ion current in steps of 8 or 16 s with 2 or 4 μA current increments. This mode will be used occasionally to establish the current-voltage characteristics of the spacecraft.

A technical mode (TECH) will be available for low-level commanding during commissioning and re-commissioning of emitters.

Start-up (STUP) is a state of the instrument at the beginning of an active mode when the emitter is being warmed up and ion emission has not yet started. Depending on ambient temperature and emitter condition it takes about 12 to 20 minutes to reach a temperature inside the emitters which is sufficient to ignite the ion beam. Within this period the "instrument mode" reported in telemetry will be already the commanded target mode, although there is no ion emission yet.

3 General Conventions

3.1 Formats

In general, the data products will be delivered in Common Data Format (CDF) version 3.6.0 as specified in [RD2].

The data products have been named according to the conventions described in the MMS CDF File format Guide [AD2].

3.2 Standards

- Global and variable attributes have been adapted from the convention given in [AD2]
- CCSDS ASCII time standard will be used
- Coordinate systems are not applicable for the ASPOC data sets
- All variables will be given in SI units

3.3 Production Procedures

The MMS/ASPOC data production software is based on the Cluster/ASPOC CAA software which in turn is based on the DSP/ASPOC and Cluster/ASPOC pipelining software versions used to generate the PP and SP data products. The data sets are generated directly from the MMS/ASPOC raw data files. The different data products for a given date range and spacecraft are generated simultaneously.

3.3.1 Usage of Data Production Software

```
L1b:    ~/software/l1b/asp_level_1.sh <start> <end> <scid> <aspid> daily
SITL:   ~/software/l1b/asp_level_1.sh <start> <end> <scid> <aspid> sitl
L2:     ~/software/l2/asp_level_2.sh <start> <end> <scid>
QL:     ~/software/ql/asp_quicklook.sh <start> <end> <scid> <aspid> daily
<start>/<end>  start/end time (UTC) in the format YYYYMMDDhhmmss
<scid>        spacecraft ID = mms1|mms2|mms3|mms4
<aspid>       ASPOC unit ID = asp1|asp2
```

3.4 Quality Control Procedures

Quality control includes visual inspection of plots produced from all data products, and spot-checks of the data products proper.

There is software in place to visualize the data products in combined displays, which facilitates the detection of inconsistencies and anomalies.

The consistency between data products will be checked in many aspects including

- Correlation between ion current and spacecraft potential,
- Correlation between ion current and total current flowing into the emitter,

- Correlation between currents in the emitter system and the derived quality flag,
- Correlation between ion current data products at different time resolutions,
- Correlation between instrument status and ion emission. This includes several checks, such as ion emission cannot occur with cold heater, in some instrument modes, without voltage applied to emitter.

Some of these checks can be carried out by the production software and raise warning messages. The other checks will be carried out manually/visually.

If an anomaly is found, which is related to the processing software, the production will be stopped, and new versions of data products will be generated after correction.

If an identified anomaly can be attributed to the instrument performance or status, a new entry into the caveats file will be generated.

The dedicated display software also supports manual entries into the caveats file.

In order to check the quality of the data products, not only the dedicated software will be used, but also the CDF validation tools will be used to check the syntax of the products.

3.5 Data Delivery Procedures

The ASPOC data products are generated by auto-processing jobs which run in the SDC production environment. In accordance with the SDC developer guide [AD1] the data files are stored in a directory structure which is organized as follows:

```
/mms/data/  
  /mms[1-4]  
    /asp[1-2]  
      /srvy  
        /l1b  
        /sitl  
          /beam  
            /YYYY  
              /MM  
          /stat  
            /YYYY  
              /MM  
        /ql  
          /plot  
            /YYYY  
              /MM  
      /aspoc  
        /srvy  
          /l2  
            /YYYY  
              /MM
```

4 ASPOC Data Products

4.1 Overview

ASPOC generates quicklook, L1b/SITL and L2 science data products. L1b/SITL and L2 data products are provided in CDF files, while quicklook products are represented by data plots saved in PNG file format. The CDF files are formatted in accordance with the MMS CDF File Format Guide. The MMS file name convention is applied to all files.

4.1.1 L1b/SITL Data Products

ASPOC Level-1b and SITL data products are containing calibrated raw data having a resolution that corresponds to the data acquisition cycle on-board. The following data products are available (given resolutions are typical values):

- Ion beam current, energy, ~ 1s resolution
- Total emitter current, ~ 1 s resolution
- Status and housekeeping, ~ 40 s resolution
- Spacecraft potential as used for control loop, ~1 s resolution
- Emitter heater current and voltage, ~ 20 s resolution
- Status flags and parameters, ~ 40 s resolution
- Secondary voltages, ~ 60 s resolution
- Internal temperatures, ~ 40 s resolution

4.1.2 L2 Data Products

ASPOC Level-2 products are daily files containing interpolated data at a resolution of 1 second (86400 records per file). For science analysis ASPOC will provide the following data:

- Ion beam current
 - individual ASPOC 1 and ASPOC 2 currents
 - and the sum
- Ion beam energies of individual ASPOCs
- Data quality information
- Individual ASPOC 1 and ASPOC 2 modes
- ASPOC ON/OFF status (ON indicates that at least one ASPOC is emitting ions)

4.2 Quicklook Data Products

ASPOC Quicklook data products are PNG graphic files containing daily plots of key parameters, which are reflecting the status of the instrument (e.g. beam current, total current, beam energy, S/C potential).

4.2.1 File Naming

The ASPOC Quicklook data products are named as follows:

mms<id>_asp1_srvy_ql_plot_YYYYMMDD_v<ver>.png

mms<id>_asp2_srvy_ql_plot_YYYYMMDD_v<ver>.png

<id> spacecraft ID [1, 2, 3 or 4]

<ver> file version in the format X.Y.Z

4.2.2 Plot Parameters

Name	Label	Dimension	Unit
S/C potential	SC_POT	0:[]	kV
Beam current	I_BEAM	0:[]	μA
Total current	I_TOTAL	0:[]	μA
Beam energy	ENERGY	0:[]	kV
Filament power	FIL_PWR	0:[]	W
Filament impedance	FIL_IMP	0:[]	Ohm

The graphic on the next page show a sample plot of ASPOC data from the Cluster mission.

The bar at the bottom of the plot indicates the quality of the ion emission:

- OFF = instrument not active
- Q1-Q5 = emission quality (1=good, 5=bad)
- CLN = cleaning active
- NOE = no emission (startup active)

In addition, the background color of the plot shows if ASPOC is active and emits a significant amount of ions.

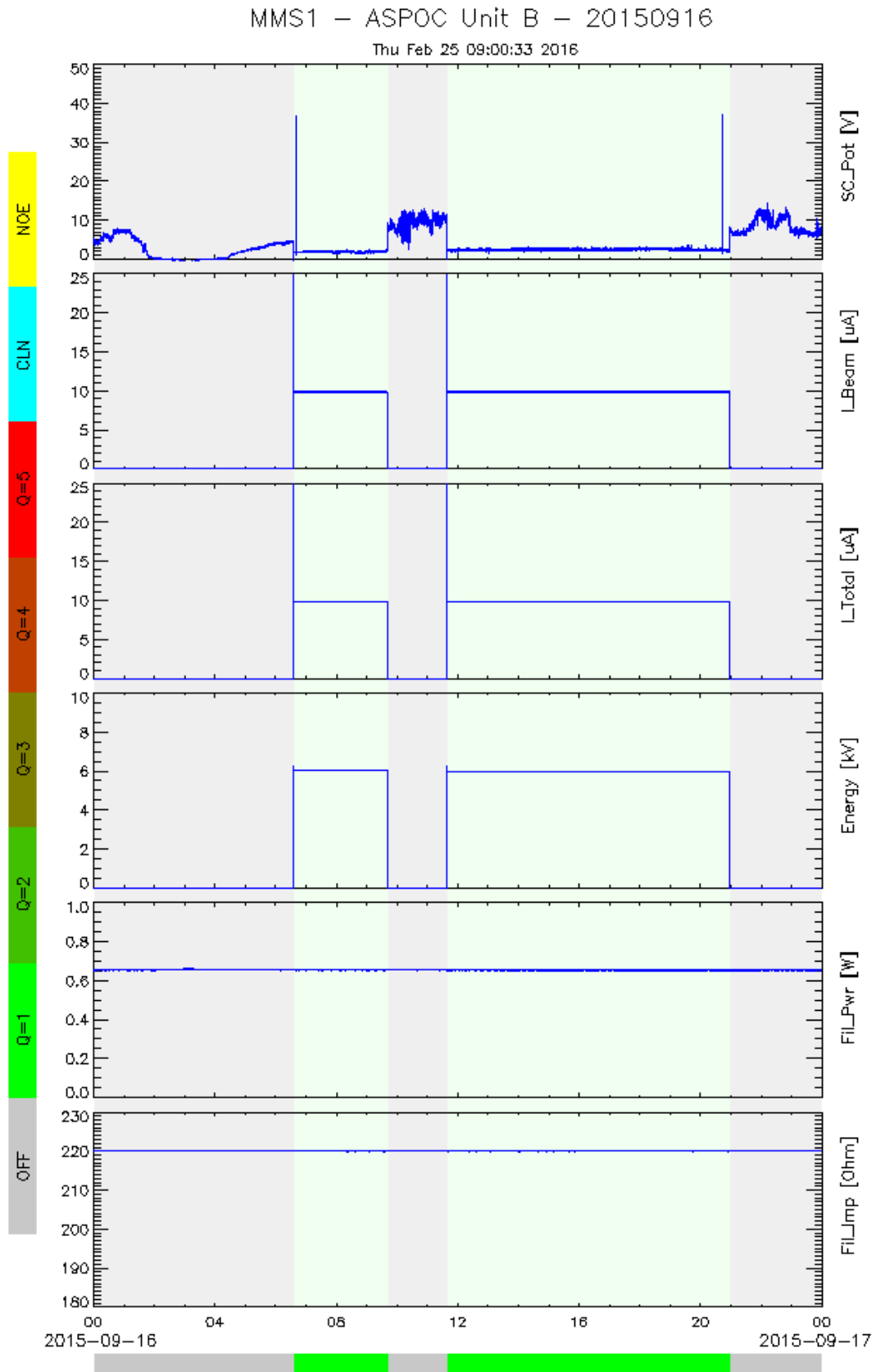

Figure 8: Sample quicklook plot

4.3 Level-1b/SITL Data Products

ASPOC Level-1b and SITL data products are daily files containing calibrated raw data. The resolution depends on the data acquisition cycle on-board (typically 1 second/40 seconds for beam/status data during nominal operation).

4.3.1 File Naming

The ASPOC Level-1b and SITL data products are named as follows:

<scid>_<unit>_srvy_<type>_<prod>_yyyymmdd_v<ver>.cdf

<scid> spacecraft ID [mms1, mms2, mms3, or mms4]

<unit> ASPOC unit [asp1 or asp2]

<type> data product type [l1b or sitl]

<prod> data product [beam or stat]

<ver> file version in the format X.Y.Z

4.3.2 Beam File Structure

Name	Description	Type	Dim	Unit
Epoch	Time base	TT2000	0:[]	ns
<scid>_<unit>_ionc	Ion beam current	REAL4	0:[]	μA
<scid>_<unit>_totc	Total beam current	REAL4	0:[]	μA
<scid>_<unit>_energy	Beam energy	REAL4	0:[]	kV
<scid>_<unit>_spot	S/C potential	REAL4	0:[]	V
<scid>_<unit>_filc	Filament current	REAL4	0:[]	mA
<scid>_<unit>_filv	Filament voltage	REAL4	0:[]	V
<scid>_<unit>_var	Time base delta time	REAL8	0:[]	ns

4.3.3 Stat File Structure

Name	Description	Type	Dim	Unit
Epoch	Time base	TT2000	0:[]	ns
<scid>_<unit>_p015v	+1.5V voltage monitor	REAL4	0:[]	V
<scid>_<unit>_p033v	+3.3V voltage monitor	REAL4	0:[]	V
<scid>_<unit>_p050v	+5.0V voltage monitor	REAL4	0:[]	V
<scid>_<unit>_p120v	+12.0V voltage monitor	REAL4	0:[]	V
<scid>_<unit>_n120v	-12.0V voltage monitor	REAL4	0:[]	V
<scid>_<unit>_tdpu	DPU board temperature	REAL4	0:[]	°C
<scid>_<unit>_tdcc	DCC board temperature	REAL4	0:[]	°C
<scid>_<unit>_tbox	E-box temperature	REAL4	0:[]	°C

<scid>_<unit>_tmod	Module temperature	REAL4	0:[]	°C
<scid>_<unit>_stat	Instrument status	UINT1	1:[4]	
<scid>_<unit>_lbl	Instrument status labels	CHAR	1:[4]	
<scid>_<unit>_var	Time base delta time	REAL8	0:[]	ns

mms<id>_asp_stat[1] : ASPOC data quality flag

- 0 = both units off
- 1 = emission; I_BEAM/I_TOTAL > 0.97
- 2 = emission; I_BEAM/I_TOTAL > 0.92
- 3 = emission; I_BEAM/I_TOTAL > 0.75
- 4 = emission; I_BEAM/I_TOTAL > 0.3
- 5 = emission; I_BEAM/I_TOTAL > 0.0
- 6 = at least one unit in cleaning mode
- 7 = at least one unit in startup mode
- 255 = fill value (no data)

mms<id>_asp_stat[2] : ASPOC mode settings

- Bits 2-0 = instrument mode
- Bits 4-3 = filament number
- Bit 5 = startup active flag
- Bit 6 = cleaning active flag
- 255 = fill value (no data)

mms<id>_asp_stat[3] : ASPOC on/off status

- 0 = instrument is not emitting
- 1 = instrument beam is active
- 255 = fill value (no data)

mms<id>_asp_stat[4] : Spare

- 255 = fill value (no data)

4.4 Level-2 Data Products

ASPOC Level-2 science products are CDF files generated on a daily basis. The data contained is averaged with a resolution of 1 second.

4.4.1 File Naming

The ASPOC Level-2 data products are named as follows:

<scid>_aspoc_srvy_l2_yyyymmdd_v<ver>.cdf

<scid> spacecraft ID [mms1, mms2, mms3 or mms4]

<ver> file version in the format X.Y.Z

4.4.2 File Structure

Name	Description	Type	Dim	Unit
Epoch	Time base	TT2000	0:[]	ns
<scid>_aspoc_ionc	ASPOC beam current	REAL4	0:[]	μA
<scid>_asp1_ionc	ASP1 ion beam current	REAL4	0:[]	μA
<scid>_asp2_ionc	ASP2 ion beam current	REAL4	0:[]	μA
<scid>_asp1_energy	ASP1 beam energy	REAL4	0:[]	kV
<scid>_asp2_energy	ASP2 beam energy	REAL4	0:[]	kV
<scid>_aspoc_status	Instrument status	UINT1	1:[4]	
<scid>_aspoc_lbl	Instrument status labels	CHAR	1:[4]	
<scid>_aspoc_var	Time base delta time	REAL8	0:[]	ns

mms<id>_asp_status[1] : ASPOC data quality flag

0 = both units off

1 = emission; $I_{\text{BEAM}}/I_{\text{TOTAL}} > 0.97$

2 = emission; $I_{\text{BEAM}}/I_{\text{TOTAL}} > 0.92$

3 = emission; $I_{\text{BEAM}}/I_{\text{TOTAL}} > 0.75$

4 = emission; $I_{\text{BEAM}}/I_{\text{TOTAL}} > 0.3$

5 = emission; $I_{\text{BEAM}}/I_{\text{TOTAL}} > 0.0$

6 = at least one unit in cleaning mode

7 = at least one unit in startup mode

255 = fill value (no data)

mms<id>_asp_status[2] : ASPOC 1 instrument mode

Bits 2-0 = instrument mode

Bits 4-3 = filament number

Bit 5 = startup active flag

Bit 6 = cleaning active flag

255 = fill value (no data)

mms<id>_asp_status[3] : ASPOC 2 instrument mode

Bits 2-0 = instrument mode

Bits 4-3 = filament number

Bit 5 = startup active flag

Bit 6 = cleaning active flag

255 = fill value (no data)

mms<id>_asp_status[4] : ASPOC ON/OFF status

0 = both instruments are not emitting

1 = at least one instrument beam is active

255 = fill value (no data)

5 Data Analysis and Visualization

The ASPOC L1b and L2 CDF science data products are fully ISTP compliant and can be read by several open-source software packages. Below is a selection of tools which can be used for the visualization and analysis of the ASPOC data (the descriptions of the tools have been taken from the respective web pages).

5.1 Autoplot (<http://autoplot.org/>)

Autoplot is an interactive browser for data on the web; give it a URL or the name of a file on your computer and it tries to create a sensible plot of the contents in the file. Autoplot was developed to allow quick and interactive browsing of data and metadata files that are often encountered on the web.

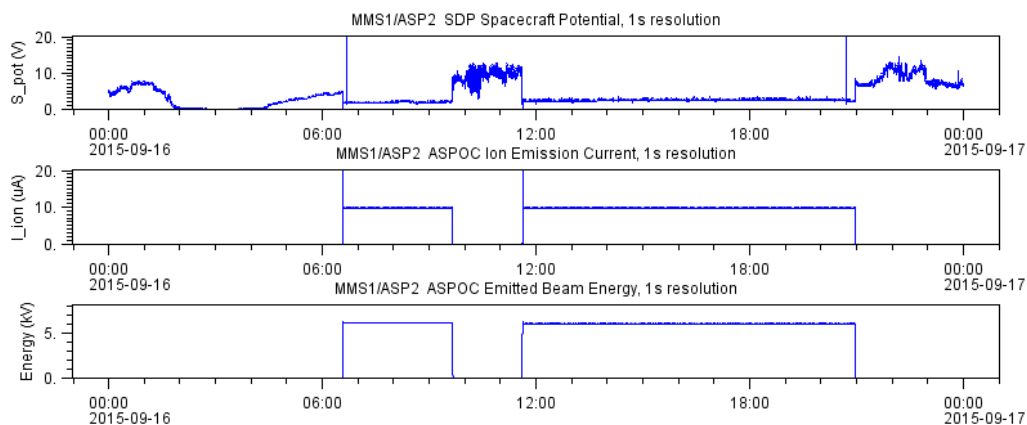

Figure 9: Sample ASPOC L1b data plot

5.2 CDAWlib (<http://spdf.gsfc.nasa.gov/CDAWlib.html>)

CDAWlib is a set of software tools written in the IDL language which is provided by the Space Physics Data Facility (SPDF). The library of routines is useful for reading in data that is stored in the CDF format and also for plotting the data variables as time series, images, radar, and spectrograms. In order to use the software IDL has to be installed on the local machine.

5.3 Qtran (<http://www.sp.ph.ic.ac.uk/csc-web/Qtran/>)

Qtran is maintained by the Space and Atmospheric group in the Physics Department at Imperial College London as part of their role in the Cluster Science Centre within the UK and the Rosetta Plasma Consortium. These formats and software, while originally designed with Cluster in mind, are quite general in applicability.

Qtran converts files between the following formats:

- NASA CDF (.cdf, specifically ISTP, CSDS, CAA and Themis designs)
- Cluster Exchange Format (.cef for the Cluster Active Archive)
- Tabular flat ASCII files (.qft)
- Delimited flat ASCII files (.qfd)

A Sample CDF Skeleton Files

A.1. L1B Beam Data CDF Skeleton File

```

! Skeleton table for the "mms1_aspl_srvy_l1b_beam" CDF.
! Generated: Friday, 31-Jul-2015 15:47:53
! CDF created/modified by CDF V3.6.0
! Skeleton table created by CDF V3.6.0_4

#header

          CDF NAME: mms1_aspl_srvy_l1b_beam
    DATA ENCODING: NETWORK
    MAJORITY: COLUMN
    FORMAT: SINGLE

! Variables  G.Attributes  V.Attributes  Records  Dims  Sizes
! -----
!          0/7           28           27           0/z           0

! CDF_COMPRESSION: None
! (Valid compression: None, GZIP.1-9, RLE.0, HUFF.0, AHUFF.0)
! CDF_CHECKSUM: MD5
! (Valid checksum: None, MD5)
! CDF_LEAPSECONDLASTUPDATED: 20150701

#GLOBALattributes

! Attribute      Entry      Data      Value
! Name           Number     Type      -----
! -----
"Project"        1:         CDF_CHAR  { "STP>Solar-Terrestrial Physics" } .
"Discipline"     1:         CDF_CHAR  { "Space Physics>" -
"                "Magnetospheric Science" } .
"Source_name"    1:         CDF_CHAR  { "MMS1>MMS Satellite Number 1" } .
"Data_type"      1:         CDF_CHAR  { "SRVY_L1B_BEAM>Level 1-b Survey
Data" } .
"Descriptor"     1:         CDF_CHAR  { "ASP1>Active Spacecraft " -
"                Potential Control - sensor 1" } .
"Data_version"  1:         CDF_CHAR  { "0.0.0" } .
"Generated_by"   1:         CDF_CHAR  { "Harald Jeszenszky @ IWF/OAW" } .
"Generation_date" 1:         CDF_CHAR  { "yyyymmdd" } .
"TITLE"          1:         CDF_CHAR  { "MMS ASPOC Beam Parameters" } .
"TEXT"           1:         CDF_CHAR  { "K. Torkar et al, Active " -
"                Spacecraft Potential " -
"                Control Investigation" }
                2:         CDF_CHAR  { "Space Science Reviews, 2014, " -
"                DOI: 10.1007/s11214-014-0049-3" }
                3:         CDF_CHAR  { "Further information:" }
                4:         CDF_CHAR  { "-" }
                5:         CDF_CHAR  { "http://www.iwf.oeaw.ac.at/" -
"                en/research/near-earth-spa" -
"                ce/mms/" }
                5:         CDF_CHAR  { "- http://mms.space.swri.edu/" } .
"MODS"           1:         CDF_CHAR  { "150224 Initial version" }
                2:         CDF_CHAR  { "150831 Minor updates and fixes" }
                3:         CDF_CHAR  { "160205 CDF file format guide
compliant" } .
"Logical_file_id" 1:         CDF_CHAR  { "mms1_aspl_srvy_l1b_beam 00000000" -

```

```

    "_v0.0.0" } .
"Logical_source"      1:  CDF_CHAR    { "mms1_asp1_srvy_1lb_beam" } .
"Logical_source_description"
  1:  CDF_CHAR    { "Level 1b Active Spacecraft" -
    " Potential Control Survey " -
    "Data" } .
"PI_name"             1:  CDF_CHAR    { "K. Torkar, R. Nakamura" } .
"PI_affiliation"      1:  CDF_CHAR    { "IWF" } .
"Mission_group"      1:  CDF_CHAR    { "MMS" } .
"Instrument_type"     1:  CDF_CHAR    { "Spacecraft Potential Control" } .
"Acknowledgement"    1:  CDF_CHAR    { "Refer to IWF/OAW for rules" -
    " of acknowledgement" } .
"Skeleton_version"   1:  CDF_CHAR    { "2.0" } .
"Software_version"   1:  CDF_CHAR    { "Draft" } .
"Rules_of_use"       1:  CDF_CHAR    { "Refer to IWF/OAW for rules of use"
} .
"Time_resolution"    1:  CDF_CHAR    { "1 second" } .
"LINK_TITLE"         1:  CDF_CHAR    { "AT GSFC" }
                   2:  CDF_CHAR    { "AT SWRI" }
                   3:  CDF_CHAR    { "LASP SDC" }
                   4:  CDF_CHAR    { "MMS1 ASPOC1" } .
"HTTP_LINK"          1:  CDF_CHAR    { "http://mms.gsfc.nasa.gov/" }
                   2:  CDF_CHAR    {
"http://mms.space.swri.edu/index.html" }
                   3:  CDF_CHAR    { "https://lasp.colorado.edu/mms/sdc/" }
                   4:  CDF_CHAR    {
"http://www.iwf.oeaw.ac.at/en/forschung/" -
    "erdnaher-weltraum/mms/mms-aspoc/" } .
"LINK_TEXT"          1:  CDF_CHAR    { "MMS home page" }
                   2:  CDF_CHAR    { "SMART package home page" }
                   3:  CDF_CHAR    { "Science Data Center" }
                   4:  CDF_CHAR    { "24-hour active spacecraft" -
    " potential control data " -
    "starting at dd Mon yyyy " -
    "00:00 available at" } .
"File_naming_convention"
  1:  CDF_CHAR    { "source_descriptor_datatype" -
    "_yyyyMMdd" } .
"ADID_ref" .
#VARIABLEattributes
"FIELDNAM"
"LABLAXIS"
"UNITS"
"CATDESC"
"DELTA_PLUS_VAR"
"DELTA_MINUS_VAR"
"VALIDMIN"
"VALIDMAX"
"SCALEMIN"
"SCALEMAX"
"FORMAT"
"FILLVAL"
"VAR_TYPE"
"SCALETYP"
"MONOTON"
"DEPEND_0"
"DISPLAY TYPE"

```

```

"DICT_KEY"
"Frame"
"SI_CONVERSION"
"Sig_digits"
"SC_id"
"VAR_NOTES"
"FORM_PTR"
"UNIT_PTR"
"SCAL_PTR"
"TIME_BASE"

#variables
! No rVariables.

#zVariables
! Variable          Data          Number          Record          Dimension
! Name             Type           Elements        Dims           Sizes           Variance        Variances
! -----
"Epoch"
                CDF_TIME_TT2000      1              0
                T

! VAR_COMPRESSION: None
! (Valid compression: None, GZIP.1-9, RLE.0, HUFF.0, AHUFF.0)
! VAR_SPARSERECORDS: None
! (Valid sparserecords: None, sRecords.PAD, sRecords.PREV)
! VAR_PADVALUE: 0000-01-01T00:00:00.000000000

! Attribute          Data          Value
! Name              Type           -----
"FIELDNAM"          CDF_CHAR      { "Time tags" }
"LABLAXIS"          CDF_CHAR      { "Epoch" }
"UNITS"             CDF_CHAR      { "ns" }
"CATDESC"           CDF_CHAR      { "Interval centred time tag rounded to " -
                "nearest msecond " }
"DELTA_PLUS_VAR"    CDF_CHAR      { "mms1_aspl_var" }
"DELTA_MINUS_VAR"   CDF_CHAR      { "mms1_aspl_var" }
"VALIDMIN"          CDF_TIME_TT2000 { 1990-01-01T00:00:00.000000000 }
"VALIDMAX"          CDF_TIME_TT2000 { 2100-01-01T00:00:00.000000000 }
"SCALEMIN"          CDF_TIME_TT2000 { 1990-01-01T00:00:00.000000000 }
"SCALEMAX"          CDF_TIME_TT2000 { 2100-01-01T00:00:00.000000000 }
"FILLVAL"           CDF_TIME_TT2000 { 9999-12-31T23:59:59.999999999 }
"VAR_TYPE"          CDF_CHAR      { "data" }
"SCALETYP"          CDF_CHAR      { "linear" }
"MONOTON"           CDF_CHAR      { "INCREASE" }
"DISPLAY_TYPE"      CDF_CHAR      { "time_series" }
"DICT_KEY"          CDF_CHAR      { "time>epoch" }
"Frame"             CDF_CHAR      { "scalar>na" }
"SI_CONVERSION"     CDF_CHAR      { "1.0e-9>s" }
"Sig_digits"        CDF_CHAR      { "14" }
"SC_id"             CDF_CHAR      { "1" }
"TIME_BASE"         CDF_CHAR      { "J2000" } .

! RV values were not requested.

! Variable          Data          Number          Record          Dimension
! Name             Type           Elements        Dims           Sizes           Variance        Variances
! -----
"mms1_aspl_ionc"
                CDF_REAL4          1              0
                T

```

```
! VAR_COMPRESSION: GZIP.6
! (Valid compression: None, GZIP.1-9, RLE.0, HUFF.0, AHUFF.0)
! VAR_SPARSERECORDS: None
! (Valid sparserecords: None, sRecords.PAD, sRecords.PREV)
! VAR_PADVALUE: -1.0e+30
```

```
! Attribute      Data
! Name           Type          Value
! -----
"FIELDNAM"      CDF_CHAR      { "Beam Current" }
"LABLAXIS"      CDF_CHAR      { "I_ion" }
"UNITS"         CDF_CHAR      { "uA" }
"CATDESC"       CDF_CHAR      { "ASPOC Ion Emission Current, " -
"1s resolution" }
"VALIDMIN"      CDF_REAL4     { 0.0 }
"VALIDMAX"      CDF_REAL4     { 100.0 }
"SCALEMIN"      CDF_REAL4     { 0.0 }
"SCALEMAX"      CDF_REAL4     { 100.0 }
"FORMAT"        CDF_CHAR      { "F5.1" }
"FILLVAL"       CDF_REAL4     { -1.0e+31 }
"VAR_TYPE"      CDF_CHAR      { "data" }
"SCALETYP"      CDF_CHAR      { "linear" }
"DEPEND_0"      CDF_CHAR      { "Epoch" }
"DISPLAY_TYPE"  CDF_CHAR      { "time_series" }
"DICT_KEY"      CDF_CHAR      { "current>mean_measured" }
"Frame"         CDF_CHAR      { "scalar>na" }
"SI_CONVERSION" CDF_CHAR      { "1.0e-6>A" }
"Sig_digits"    CDF_CHAR      { "4" }
"SC_id"         CDF_CHAR      { "1" } .
```

! RV values were not requested.

```
! Variable      Data      Number      Record      Dimension
! Name          Type      Elements    Dims        Sizes        Variance    Variances
! -----
```

```
"mms1_aspl_totc"
                        CDF_REAL4      1            0            T
```

```
! VAR_COMPRESSION: GZIP.6
! (Valid compression: None, GZIP.1-9, RLE.0, HUFF.0, AHUFF.0)
! VAR_SPARSERECORDS: None
! (Valid sparserecords: None, sRecords.PAD, sRecords.PREV)
! VAR_PADVALUE: -1.0e+30
```

```
! Attribute      Data
! Name           Type          Value
! -----
"FIELDNAM"      CDF_CHAR      { "Total Current" }
"LABLAXIS"      CDF_CHAR      { "I_tot" }
"UNITS"         CDF_CHAR      { "uA" }
"CATDESC"       CDF_CHAR      { "ASPOC Total Extractor Current, " -
"1s resolution" }
"VALIDMIN"      CDF_REAL4     { 0.0 }
"VALIDMAX"      CDF_REAL4     { 100.0 }
"SCALEMIN"      CDF_REAL4     { 0.0 }
"SCALEMAX"      CDF_REAL4     { 100.0 }
"FORMAT"        CDF_CHAR      { "F5.1" }
"FILLVAL"       CDF_REAL4     { -1.0e+31 }
"VAR_TYPE"      CDF_CHAR      { "data" }
"SCALETYP"      CDF_CHAR      { "linear" }
"DEPEND_0"      CDF_CHAR      { "Epoch" }
"DISPLAY_TYPE"  CDF_CHAR      { "time_series" }
"DICT_KEY"      CDF_CHAR      { "current>mean_measured" }
"Frame"         CDF_CHAR      { "scalar>na" }
"SI_CONVERSION" CDF_CHAR      { "1.0e-6>A" }
"Sig_digits"    CDF_CHAR      { "4" }
"SC_id"         CDF_CHAR      { "1" } .
```

! RV values were not requested.

! Variable Name	Data Type	Number Elements	Dims	Sizes	Record Variance	Dimension Variances
-----------------	-----------	-----------------	------	-------	-----------------	---------------------

"mms1_aspl_energy"	CDF_REAL4	1	0		T	
--------------------	-----------	---	---	--	---	--

! VAR_COMPRESSION: GZIP.6
 ! (Valid compression: None, GZIP.1-9, RLE.0, HUFF.0, AHUFF.0)
 ! VAR_SPARSERECORDS: None
 ! (Valid sparserecords: None, sRecords.PAD, sRecords.PREV)
 ! VAR_PADVALUE: -1.0e+30

! Attribute Name	Data Type	Value
------------------	-----------	-------

"FIELDNAM"	CDF_CHAR	{ "Beam Energy" }
"LABLAXIS"	CDF_CHAR	{ "Energy" }
"UNITS"	CDF_CHAR	{ "kV" }
"CATDESC"	CDF_CHAR	{ "ASPOC Emitted Beam Energy, " - "1s resolution" }
"VALIDMIN"	CDF_REAL4	{ 0.0 }
"VALIDMAX"	CDF_REAL4	{ 12.5 }
"SCALEMIN"	CDF_REAL4	{ 0.0 }
"SCALEMAX"	CDF_REAL4	{ 12.5 }
"FORMAT"	CDF_CHAR	{ "F5.2" }
"FILLVAL"	CDF_REAL4	{ -1.0e+31 }
"VAR_TYPE"	CDF_CHAR	{ "data" }
"SCALETYP"	CDF_CHAR	{ "linear" }
"DEPEND_0"	CDF_CHAR	{ "Epoch" }
"DISPLAY_TYPE"		
"DICT_KEY"	CDF_CHAR	{ "time_series" }
"Frame"	CDF_CHAR	{ "energy>mean_measured" }
"SI_CONVERSION"		
"Sig_digits"	CDF_CHAR	{ "1.0e3>V" }
"SC_id"	CDF_CHAR	{ "4" }
"SC_id"	CDF_CHAR	{ "1" } .

! RV values were not requested.

! Variable Name	Data Type	Number Elements	Dims	Sizes	Record Variance	Dimension Variances
-----------------	-----------	-----------------	------	-------	-----------------	---------------------

"mms1_aspl_spot"	CDF_REAL4	1	0		T	
------------------	-----------	---	---	--	---	--

! VAR_COMPRESSION: GZIP.6
 ! (Valid compression: None, GZIP.1-9, RLE.0, HUFF.0, AHUFF.0)
 ! VAR_SPARSERECORDS: None
 ! (Valid sparserecords: None, sRecords.PAD, sRecords.PREV)
 ! VAR_PADVALUE: -1.0e+30

! Attribute Name	Data Type	Value
------------------	-----------	-------

"FIELDNAM"	CDF_CHAR	{ "Spacecraft Potential" }
"LABLAXIS"	CDF_CHAR	{ "S_pot" }
"UNITS"	CDF_CHAR	{ "V" }
"CATDESC"	CDF_CHAR	{ "SDP Spacecraft Potential, 1s resolution" }
"VALIDMIN"	CDF_REAL4	{ -50.0 }
"VALIDMAX"	CDF_REAL4	{ 200.0 }
"SCALEMIN"	CDF_REAL4	{ 0.0 }
"SCALEMAX"	CDF_REAL4	{ 100.0 }
"FORMAT"	CDF_CHAR	{ "F5.1" }
"FILLVAL"	CDF_REAL4	{ -1.0e+31 }
"VAR_TYPE"	CDF_CHAR	{ "data" }
"SCALETYP"	CDF_CHAR	{ "linear" }
"DEPEND_0"	CDF_CHAR	{ "Epoch" }
"DISPLAY_TYPE"		

```

    "DICT_KEY"      CDF_CHAR      { "time_series" }
    "Frame"        CDF_CHAR      { "potential>mean_measured" }
    "SI_CONVERSION"
    "Sig_digits"   CDF_CHAR      { "1.0>V" }
    "SC_id"        CDF_CHAR      { "4" }
    "SC_id"        CDF_CHAR      { "1" } .

! RV values were not requested.

! Variable          Data          Number          Record          Dimension
! Name             Type           Elements        Dims            Sizes           Variance        Variances
! -----
"mms1_aspl_filc"
    CDF_REAL4      1              0
    T

! VAR_COMPRESSION: GZIP.6
! (Valid compression: None, GZIP.1-9, RLE.0, HUFF.0, AHUFF.0)
! VAR_SPARSERECORDS: None
! (Valid sparserecords: None, sRecords.PAD, sRecords.PREV)
! VAR_PADVALUE: -1.0e+30

! Attribute          Data
! Name              Type              Value
! -----
"FIELDNAM"         CDF_CHAR          { "Filament Current" }
"LABLAXIS"         CDF_CHAR          { "I_fil" }
"UNITS"            CDF_CHAR          { "mA" }
"CATDESC"          CDF_CHAR          { "ASPOC Filament Current, 20s resolution" }
"VALIDMIN"         CDF_REAL4         { 0.0 }
"VALIDMAX"         CDF_REAL4         { 100.0 }
"SCALEMIN"         CDF_REAL4         { 0.0 }
"SCALEMAX"         CDF_REAL4         { 100.0 }
"FORMAT"           CDF_CHAR          { "F5.1" }
"FILLVAL"          CDF_REAL4         { -1.0e+31 }
"VAR_TYPE"         CDF_CHAR          { "data" }
"SCALETYP"         CDF_CHAR          { "linear" }
"DEPEND_0"         CDF_CHAR          { "Epoch" }
"DISPLAY_TYPE"
"DICT_KEY"         CDF_CHAR          { "time_series" }
"Frame"           CDF_CHAR          { "current>mean_measured" }
"SI_CONVERSION"
"Sig_digits"       CDF_CHAR          { "1.0e-3>A" }
"SC_id"           CDF_CHAR          { "4" }
"SC_id"           CDF_CHAR          { "1" } .

! RV values were not requested.

! Variable          Data          Number          Record          Dimension
! Name             Type           Elements        Dims            Sizes           Variance        Variances
! -----
"mms1_aspl_filv"
    CDF_REAL4      1              0
    T

! VAR_COMPRESSION: GZIP.6
! (Valid compression: None, GZIP.1-9, RLE.0, HUFF.0, AHUFF.0)
! VAR_SPARSERECORDS: None
! (Valid sparserecords: None, sRecords.PAD, sRecords.PREV)
! VAR_PADVALUE: -1.0e+30

! Attribute          Data
! Name              Type              Value
! -----
"FIELDNAM"         CDF_CHAR          { "Filament Voltage" }
"LABLAXIS"         CDF_CHAR          { "V_fil" }
"UNITS"            CDF_CHAR          { "V" }
"CATDESC"          CDF_CHAR          { "ASPOC Filament Voltage, 20s resolution" }
"VALIDMIN"         CDF_REAL4         { 0.0 }
"VALIDMAX"         CDF_REAL4         { 20.0 }
"SCALEMIN"         CDF_REAL4         { 0.0 }

```

```

"SCALEMAX" CDF_REAL4 { 20.0 }
"FORMAT" CDF_CHAR { "F4.1" }
"FILLVAL" CDF_REAL4 { -1.0e+31 }
"VAR_TYPE" CDF_CHAR { "data" }
"SCALETYP" CDF_CHAR { "linear" }
"DEPEND_0" CDF_CHAR { "Epoch" }
"DISPLAY_TYPE" CDF_CHAR { "time_series" }
"DICT_KEY" CDF_CHAR { "potential>mean_measured" }
"Frame" CDF_CHAR { "scalar>na" }
"SI_CONVERSION" CDF_CHAR { "1.0>V" }
"Sig_digits" CDF_CHAR { "4" }
"SC_id" CDF_CHAR { "1" } .

! RV values were not requested.

! Variable Data Number Record Dimension
! Name Type Elements Dims Sizes Variance Variances
! -----
"mms1_asp1_var" CDF_REAL8 1 0 F

! VAR_COMPRESSION: None
! (Valid compression: None, GZIP.1-9, RLE.0, HUFF.0, AHUFF.0)
! VAR_SPARSERECORDS: None
! (Valid sparserecords: None, sRecords.PAD, sRecords.PREV)
! VAR_PADVALUE: -1.0e+30

! Attribute Data Value
! Name Type Value
! -----
"FIELDNAM" CDF_CHAR { "Half Interval" }
"LABLAXIS" CDF_CHAR { "Half_int" }
"UNITS" CDF_CHAR { "ns" }
"CATDESC" CDF_CHAR { "Half with of measurement interval" }
"VALIDMIN" CDF_REAL8 { 0.0 }
"VALIDMAX" CDF_REAL8 { 1.275e+10 }
"FORMAT" CDF_CHAR { "F13.1" }
"VAR_TYPE" CDF_CHAR { "support_data" }
"SI_CONVERSION" CDF_CHAR { "1.0e-9>s" } .

! NRV value follows...

[] = 5.0e+08

#end

```

Table 1: L1B Beam Data CDF Skeleton File

A.2. L1B Status Data CDF Skeleton File

```

! Skeleton table for the "mms4_asp2_srvy_l1b_stat" CDF.
! Generated: Friday, 31-Jul-2015 15:47:53
! CDF created/modified by CDF V3.6.0
! Skeleton table created by CDF V3.6.0_4

#header

          CDF NAME: mms4_asp2_srvy_l1b_stat
    DATA ENCODING: NETWORK
      MAJORITY: COLUMN
        FORMAT: SINGLE

! Variables  G.Attributes  V.Attributes  Records  Dims  Sizes
! -----
!    0/12          28          29          0/z      0
! -----

! CDF_COMPRESSION: None
! (Valid compression: None, GZIP.1-9, RLE.0, HUFF.0, AHUFF.0)
! CDF_CHECKSUM: MD5
! (Valid checksum: None, MD5)
! CDF_LEAPSECONDLASTUPDATED: 20150701

#GLOBALattributes

! Attribute      Entry      Data      Value
! Name           Number     Type       -----
! -----
"Project"        1:        CDF_CHAR   { "STP>Solar-Terrestrial Physics" } .
"Discipline"     1:        CDF_CHAR   { "Space Physics>" -
"                "Magnetospheric Science" } .
"Source_name"    1:        CDF_CHAR   { "MMS4>MMS Satellite Number 4" } .
"Data_type"      1:        CDF_CHAR   { "SRVY_L1B_STAT>Level 1-b Survey
Data" } .
"Descriptor"     1:        CDF_CHAR   { "ASP2>Active Spacecraft " -
"                Potential Control - sensor 2" } .
"Data_version"  1:        CDF_CHAR   { "0.0.0" } .
"Generated_by"   1:        CDF_CHAR   { "Harald Jeszenszky @ IWF/OAW" } .
"Generation_date" 1:        CDF_CHAR   { "yyyymmdd" } .
"TITLE"          1:        CDF_CHAR   { "MMS ASPOC Status Parameters" } .
"TEXT"           1:        CDF_CHAR   { "K. Torkar et al, Active " -
"                Spacecraft Potential " -
"                Control Investigation" }
                2:        CDF_CHAR   { "Space Science Reviews, 2014, " -
"                DOI: 10.1007/s11214-014-0049-3" }
                3:        CDF_CHAR   { "Further information:" }
                4:        CDF_CHAR   { "- " -
"                http://www.iwf.oeaw.ac.at/" -
"                en/research/near-earth-spa" -
"                ce/mms/" }
                5:        CDF_CHAR   { "- http://mms.space.swri.edu/" } .
"MODS"           1:        CDF_CHAR   { "150224 Initial version" }
                2:        CDF_CHAR   { "150831 Minor updates and fixes" }
                3:        CDF_CHAR   { "160205 CDF file format guide
compliant" } .
"Logical_file_id" 1:        CDF_CHAR   { "mms4_asp2_srvy_l1b_stat_00000000" -
"                _v0.0.0" } .
"Logical_source" 1:        CDF_CHAR   { "mms4_asp2_srvy_l1b_stat" } .

```

```

"Logical_source_description"
      1: CDF_CHAR { "Level 1b Active Spacecraft" -
                  " Potential Control Survey " -
                  "Data" } .

"PI_name"      1: CDF_CHAR { "K. Torkar, R. Nakamura" } .

"PI_affiliation" 1: CDF_CHAR { "IWF" } .

"Mission_group" 1: CDF_CHAR { "MMS" } .

"Instrument_type" 1: CDF_CHAR { "Spacecraft Potential Control" } .

"Acknowledgement" 1: CDF_CHAR { "Refer to IWF/OAW for rules" -
                                " of acknowledgement" } .

"Skeleton_version" 1: CDF_CHAR { "2.0" } .

"Software_version" 1: CDF_CHAR { "Draft" } .

"Rules_of_use"    1: CDF_CHAR { "Refer to IWF/OAW for rules of use"
} .

"Time_resolution" 1: CDF_CHAR { "40 seconds" } .

"LINK_TITLE"     1: CDF_CHAR { "AT GSFC" }
                  2: CDF_CHAR { "AT SWRI" }
                  3: CDF_CHAR { "LASP SDC" }
                  4: CDF_CHAR { "MMS4 ASPOC2" } .

"HTTP_LINK"      1: CDF_CHAR { "http://mms.gsfc.nasa.gov/" }
                  2: CDF_CHAR {
"http://mms.space.swri.edu/index.html" }
                  3: CDF_CHAR { "https://lasp.colorado.edu/mms/sdc/" }
                  4: CDF_CHAR {
"http://www.iwf.oeaw.ac.at/en/forschung/" -
"erdnaher-weltraum/mms/mms-as poc/" } .

"LINK_TEXT"      1: CDF_CHAR { "MMS home page" }
                  2: CDF_CHAR { "SMART package home page" }
                  3: CDF_CHAR { "Science Data Center" }
                  4: CDF_CHAR { "24-hour active spacecraft" -
                                " potential control data " -
                                "starting at dd Mon yyyy " -
                                "00:00 available at" } .

"File_naming_convention"
      1: CDF_CHAR { "source_descriptor_datatype" -
                  "_yyyyMMdd" } .

"ADID_ref" .

#VARIABLEattributes

"FIELDNAM"
"LABLAXIS"
"UNITS"
"CATDESC"
"DELTA_PLUS_VAR"
"DELTA_MINUS_VAR"
"VALIDMIN"
"VALIDMAX"
"SCALEMIN"
"SCALEMAX"
"FORMAT"
"FILLVAL"
"VAR_TYPE"
"SCALETYP"
"MONOTON"
"DEPEND_0"
"DISPLAY_TYPE"
"DICT_KEY"
"Frame"
"SI_CONVERSION"
"Sig digits"

```

```

"SC_id"
"VAR_NOTES"
"FORM_PTR"
"UNIT_PTR"
"SCAL_PTR"
"DEPEND_1"
"LABL_PTR_1"
"TIME_BASE"

#variables

! No rVariables.

#zVariables

! Variable          Data          Number          Record          Dimension
! Name             Type           Elements        Dims           Sizes           Variance        Variances
! -----

"Epoch"
                CDF_TIME_TT2000          1              0
                T

! VAR_COMPRESSION: None
! (Valid compression: None, GZIP.1-9, RLE.0, HUFF.0, AHUFF.0)
! VAR_SPARSERECORDS: None
! (Valid sparserecords: None, sRecords.PAD, sRecords.PREV)
! VAR_PADVALUE: 0000-01-01T00:00:00.000000000

! Attribute          Data
! Name              Type              Value
! -----

"FIELDNAM"          CDF_CHAR          { "Time tags" }
"LABLAXIS"          CDF_CHAR          { "Epoch" }
"UNITS"             CDF_CHAR          { "ns" }
"CATDESC"           CDF_CHAR          { "Interval centred time tag rounded to " -
                    "nearest msecond " }
"DELTA_PLUS_VAR"    CDF_CHAR          { "mms4_asp2_var" }
"DELTA_MINUS_VAR"  CDF_CHAR          { "mms4_asp2_var" }
"VALIDMIN"          CDF_TIME_TT2000  { 1990-01-01T00:00:00.000000000 }
"VALIDMAX"          CDF_TIME_TT2000  { 2100-01-01T00:00:00.000000000 }
"SCALEMIN"          CDF_TIME_TT2000  { 1990-01-01T00:00:00.000000000 }
"SCALEMAX"          CDF_TIME_TT2000  { 2100-01-01T00:00:00.000000000 }
"FILLVAL"           CDF_TIME_TT2000  { 9999-12-31T23:59:59.999999999 }
"VAR_TYPE"          CDF_CHAR          { "data" }
"SCALETYP"          CDF_CHAR          { "linear" }
"MONOTON"           CDF_CHAR          { "INCREASE" }
"DISPLAY_TYPE"      CDF_CHAR          { "time_series" }
"DICT_KEY"          CDF_CHAR          { "time>epoch" }
"Frame"             CDF_CHAR          { "scalar>na" }
"SI_CONVERSION"     CDF_CHAR          { "1.0e-9>s" }
"Sig_digits"        CDF_CHAR          { "14" }
"SC_id"             CDF_CHAR          { "4" }
"TIME_BASE"         CDF_CHAR          { "J2000" } .

! RV values were not requested.

! Variable          Data          Number          Record          Dimension
! Name             Type           Elements        Dims           Sizes           Variance        Variances
! -----

"mms4_asp2_p015v"
                CDF_REAL4          1              0
                T

! VAR_COMPRESSION: GZIP.6
! (Valid compression: None, GZIP.1-9, RLE.0, HUFF.0, AHUFF.0)

```

```

! VAR_SPARSERECORDS: None
! (Valid sparserecords: None, sRecords.PAD, sRecords.PREV)
! VAR_PADVALUE: -1.0e+30

! Attribute      Data
! Name           Type          Value
! -----
!

"FIELDNAM"      CDF_CHAR      { "+1.5V Monitor" }
"LABLAXIS"      CDF_CHAR      { "+1.5_mon" }
"UNITS"         CDF_CHAR      { "v" }
"CATDESC"       CDF_CHAR      { "ASPOC +1.5V Voltage Monitor, " -
"60s resolution" }
"VALIDMIN"      CDF_REAL4     { 0.0 }
"VALIDMAX"      CDF_REAL4     { 5.0 }
"SCALEMIN"      CDF_REAL4     { 0.0 }
"SCALEMAX"      CDF_REAL4     { 100.0 }
"FORMAT"        CDF_CHAR      { "F5.3" }
"FILLVAL"       CDF_REAL4     { -1.0e+31 }
"VAR_TYPE"      CDF_CHAR      { "data" }
"SCALETYP"      CDF_CHAR      { "linear" }
"DEPEND_0"      CDF_CHAR      { "Epoch" }
"DISPLAY_TYPE"  CDF_CHAR      { "time_series" }
"DICTIONARY"    CDF_CHAR      { "potential>mean_measured" }
"Frame"         CDF_CHAR      { "scalar>na" }
"SI_CONVERSION" CDF_CHAR      { "1.0>V" }
"Sig_digits"    CDF_CHAR      { "4" }
"SC_id"         CDF_CHAR      { "4" } .

! RV values were not requested.

! Variable      Data      Number      Record      Dimension
! Name          Type      Elements    Dims      Sizes      Variance    Variances
! -----
!

"mms4_asp2_p033v"
                        CDF_REAL4      1          0          T

! VAR_COMPRESSION: GZIP.6
! (Valid compression: None, GZIP.1-9, RLE.0, HUFF.0, AHUFF.0)
! VAR_SPARSERECORDS: None
! (Valid sparserecords: None, sRecords.PAD, sRecords.PREV)
! VAR_PADVALUE: -1.0e+30

! Attribute      Data
! Name           Type          Value
! -----
!

"FIELDNAM"      CDF_CHAR      { "+3.3V Monitor" }
"LABLAXIS"      CDF_CHAR      { "+3.3_mon" }
"UNITS"         CDF_CHAR      { "v" }
"CATDESC"       CDF_CHAR      { "ASPOC +3.3V Voltage Monitor, " -
"60s resolution" }
"VALIDMIN"      CDF_REAL4     { 0.0 }
"VALIDMAX"      CDF_REAL4     { 5.0 }
"SCALEMIN"      CDF_REAL4     { 0.0 }
"SCALEMAX"      CDF_REAL4     { 100.0 }
"FORMAT"        CDF_CHAR      { "F5.3" }
"FILLVAL"       CDF_REAL4     { -1.0e+31 }
"VAR_TYPE"      CDF_CHAR      { "data" }
"SCALETYP"      CDF_CHAR      { "linear" }
"DEPEND_0"      CDF_CHAR      { "Epoch" }
"DISPLAY_TYPE"  CDF_CHAR      { "time_series" }
"DICTIONARY"    CDF_CHAR      { "potential>mean_measured" }
"Frame"         CDF_CHAR      { "scalar>na" }
"SI_CONVERSION" CDF_CHAR      { "1.0>V" }
"Sig_digits"    CDF_CHAR      { "4" }
"SC_id"         CDF_CHAR      { "4" } .

! RV values were not requested.

```

```

! Variable      Data      Number      Record      Dimension
! Name          Type      Elements    Dims        Sizes        Variance    Variances
! -----
!
"mms4_asp2_p050v"
      CDF_REAL4      1      0      T

! VAR_COMPRESSION: GZIP.6
! (Valid compression: None, GZIP.1-9, RLE.0, HUFF.0, AHUFF.0)
! VAR_SPARSERECORDS: None
! (Valid sparserecords: None, sRecords.PAD, sRecords.PREV)
! VAR_PADVALUE: -1.0e+30

! Attribute      Data
! Name           Type           Value
! -----
!
"FIELDNAM"      CDF_CHAR      { "+5V Monitor" }
"LABLAXIS"      CDF_CHAR      { "+5_mon" }
"UNITS"         CDF_CHAR      { "V" }
"CATDESC"       CDF_CHAR      { "ASPOC +5V Voltage Monitor, " -
      "60s resolution" }
"VALIDMIN"      CDF_REAL4     { 0.0 }
"VALIDMAX"      CDF_REAL4     { 6.5 }
"SCALEMIN"      CDF_REAL4     { 0.0 }
"SCALEMAX"      CDF_REAL4     { 100.0 }
"FORMAT"        CDF_CHAR      { "F5.3" }
"FILLVAL"       CDF_REAL4     { -1.0e+31 }
"VAR_TYPE"      CDF_CHAR      { "data" }
"SCALETYP"     CDF_CHAR      { "linear" }
"DEPEND_0"     CDF_CHAR      { "Epoch" }
"DISPLAY_TYPE"  CDF_CHAR      { "time_series" }
"DICT_KEY"      CDF_CHAR      { "potential>mean_measured" }
"Frame"         CDF_CHAR      { "scalar>na" }
"SI_CONVERSION" CDF_CHAR      { "1.0>V" }
"Sig_digits"    CDF_CHAR      { "4" }
"SC_id"         CDF_CHAR      { "4" } .

! RV values were not requested.

! Variable      Data      Number      Record      Dimension
! Name          Type      Elements    Dims        Sizes        Variance    Variances
! -----
!
"mms4_asp2_p120v"
      CDF_REAL4      1      0      T

! VAR_COMPRESSION: GZIP.6
! (Valid compression: None, GZIP.1-9, RLE.0, HUFF.0, AHUFF.0)
! VAR_SPARSERECORDS: None
! (Valid sparserecords: None, sRecords.PAD, sRecords.PREV)
! VAR_PADVALUE: -1.0e+30

! Attribute      Data
! Name           Type           Value
! -----
!
"FIELDNAM"      CDF_CHAR      { "+12V Monitor" }
"LABLAXIS"      CDF_CHAR      { "+12_mon" }
"UNITS"         CDF_CHAR      { "V" }
"CATDESC"       CDF_CHAR      { "ASPOC +12V Voltage Monitor, " -
      "60s resolution" }
"VALIDMIN"      CDF_REAL4     { 0.0 }
"VALIDMAX"      CDF_REAL4     { 13.9 }
"SCALEMIN"      CDF_REAL4     { 0.0 }
"SCALEMAX"      CDF_REAL4     { 100.0 }
"FORMAT"        CDF_CHAR      { "F5.2" }
"FILLVAL"       CDF_REAL4     { -1.0e+31 }
"VAR_TYPE"      CDF_CHAR      { "data" }
"SCALETYP"     CDF_CHAR      { "linear" }
"DEPEND_0"     CDF_CHAR      { "Epoch" }
"DISPLAY_TYPE"  CDF_CHAR      { "time_series" }

```

```

"DICT_KEY" CDF_CHAR { "potential>mean_measured" }
"Frame" CDF_CHAR { "scalar>na" }
"SI_CONVERSION" CDF_CHAR { "1.0>V" }
"Sig_digits" CDF_CHAR { "4" }
"SC_id" CDF_CHAR { "4" } .

! RV values were not requested.

! Variable Data Number Record Dimension
! Name Type Elements Dims Sizes Variance Variances
! -----
"mms4_asp2_n120v"
CDF_REAL4 1 0 T

! VAR_COMPRESSION: GZIP.6
! (Valid compression: None, GZIP.1-9, RLE.0, HUFF.0, AHUFF.0)
! VAR_SPARSERECORDS: None
! (Valid sparserecords: None, sRecords.PAD, sRecords.PREV)
! VAR_PADVALUE: -1.0e+30

! Attribute Data Value
! Name Type Value
! -----
"FIELDNAM" CDF_CHAR { "-12V Monitor" }
"LABLAXIS" CDF_CHAR { "-12_mon" }
"UNITS" CDF_CHAR { "v" }
"CATDESC" CDF_CHAR { "ASPOC -12.0V Voltage Monitor, " -
"60s resolution" }
"VALIDMIN" CDF_REAL4 { -17.3 }
"VALIDMAX" CDF_REAL4 { 0.0 }
"SCALEMIN" CDF_REAL4 { 0.0 }
"SCALEMAX" CDF_REAL4 { 20.0 }
"FORMAT" CDF_CHAR { "F6.2" }
"FILLVAL" CDF_REAL4 { -1.0e+31 }
"VAR_TYPE" CDF_CHAR { "data" }
"SCALETYP" CDF_CHAR { "linear" }
"DEPEND_0" CDF_CHAR { "Epoch" }
"DISPLAY_TYPE" CDF_CHAR { "time_series" }
"DICT_KEY" CDF_CHAR { "potential>mean_measured" }
"Frame" CDF_CHAR { "scalar>na" }
"SI_CONVERSION" CDF_CHAR { "1.0>V" }
"Sig_digits" CDF_CHAR { "4" }
"SC_id" CDF_CHAR { "4" } .

! RV values were not requested.

! Variable Data Number Record Dimension
! Name Type Elements Dims Sizes Variance Variances
! -----
"mms4_asp2_tdpu"
CDF_REAL4 1 0 T

! VAR_COMPRESSION: GZIP.6
! (Valid compression: None, GZIP.1-9, RLE.0, HUFF.0, AHUFF.0)
! VAR_SPARSERECORDS: None
! (Valid sparserecords: None, sRecords.PAD, sRecords.PREV)
! VAR_PADVALUE: -1.0e+30

! Attribute Data Value
! Name Type Value
! -----
"FIELDNAM" CDF_CHAR { "DPU Temperature" }
"LABLAXIS" CDF_CHAR { "T_dpu" }
"UNITS" CDF_CHAR { "K (Celsius)" }
"CATDESC" CDF_CHAR { "ASPOC DPU Temperature, 60s resolution" }
"VALIDMIN" CDF_REAL4 { -273.0 }
"VALIDMAX" CDF_REAL4 { 227.0 }
"SCALEMIN" CDF_REAL4 { 0.0 }

```

```

"SCALEMAX" CDF_REAL4 { 100.0 }
"FORMAT" CDF_CHAR { "F6.1" }
"FILLVAL" CDF_REAL4 { -1.0e+31 }
"VAR_TYPE" CDF_CHAR { "data" }
"SCALETYP" CDF_CHAR { "linear" }
"DEPEND_0" CDF_CHAR { "Epoch" }
"DISPLAY_TYPE" CDF_CHAR { "time_series" }
"DICTIONARY" CDF_CHAR { "temperature>mean_measured" }
"Frame" CDF_CHAR { "scalar>na" }
"SI_CONVERSION" CDF_CHAR { "1.0>K (Celsius)" }
"Sig_digits" CDF_CHAR { "4" }
"SC_id" CDF_CHAR { "4" } .

! RV values were not requested.

! Variable Data Number Record Dimension
! Name Type Elements Dims Sizes Variance Variances
! -----
"mms4_asp2_tdcc"
CDF_REAL4 1 0 T

! VAR_COMPRESSION: GZIP.6
! (Valid compression: None, GZIP.1-9, RLE.0, HUFF.0, AHUFF.0)
! VAR_SPARSERECORDS: None
! (Valid sparserecords: None, sRecords.PAD, sRecords.PREV)
! VAR_PADVALUE: -1.0e+30

! Attribute Data Value
! Name Type Value
! -----
"FIELDNAM" CDF_CHAR { "DCC Temperature" }
"LABLAXIS" CDF_CHAR { "T_dcc" }
"UNITS" CDF_CHAR { "K (Celsius)" }
"CATDESC" CDF_CHAR { "ASPOC DCC Temperature, 40s resolution" }
"VALIDMIN" CDF_REAL4 { -273.0 }
"VALIDMAX" CDF_REAL4 { 227.0 }
"SCALEMIN" CDF_REAL4 { 0.0 }
"SCALEMAX" CDF_REAL4 { 100.0 }
"FORMAT" CDF_CHAR { "F6.1" }
"FILLVAL" CDF_REAL4 { -1.0e+31 }
"VAR_TYPE" CDF_CHAR { "data" }
"SCALETYP" CDF_CHAR { "linear" }
"DEPEND_0" CDF_CHAR { "Epoch" }
"DISPLAY_TYPE" CDF_CHAR { "time_series" }
"DICTIONARY" CDF_CHAR { "temperature>mean_measured" }
"Frame" CDF_CHAR { "scalar>na" }
"SI_CONVERSION" CDF_CHAR { "1.0>K (Celsius)" }
"Sig_digits" CDF_CHAR { "4" }
"SC_id" CDF_CHAR { "4" } .

! RV values were not requested.

! Variable Data Number Record Dimension
! Name Type Elements Dims Sizes Variance Variances
! -----
"mms4_asp2_tbox"
CDF_REAL4 1 0 T

! VAR_COMPRESSION: GZIP.6
! (Valid compression: None, GZIP.1-9, RLE.0, HUFF.0, AHUFF.0)
! VAR_SPARSERECORDS: None
! (Valid sparserecords: None, sRecords.PAD, sRecords.PREV)
! VAR_PADVALUE: -1.0e+30

! Attribute Data Value
! Name Type Value
! -----

```

```
"FIELDNAM" CDF_CHAR { "BOX Temperature" }
"LABLAXIS" CDF_CHAR { "T_box" }
"UNITS" CDF_CHAR { "K (Celsius)" }
"CATDESC" CDF_CHAR { "ASPOC E-box Temperature, 40s resolution" }
"VALIDMIN" CDF_REAL4 { -273.0 }
"VALIDMAX" CDF_REAL4 { 227.0 }
"SCALEMIN" CDF_REAL4 { 0.0 }
"SCALEMAX" CDF_REAL4 { 100.0 }
"FORMAT" CDF_CHAR { "F6.1" }
"FILLVAL" CDF_REAL4 { -1.0e+31 }
"VAR_TYPE" CDF_CHAR { "data" }
"SCALETYP" CDF_CHAR { "linear" }
"DEPEND_0" CDF_CHAR { "Epoch" }
"DISPLAY_TYPE" CDF_CHAR { "time_series" }
"DICTIONARY" CDF_CHAR { "temperature>mean_measured" }
"Frame" CDF_CHAR { "scalar>na" }
"SI_CONVERSION" CDF_CHAR { "1.0>K (Celsius)" }
"Sig_digits" CDF_CHAR { "4" }
"SC_id" CDF_CHAR { "4" } .
```

! RV values were not requested.

! Variable Name	Data Type	Number Elements	Dims	Sizes	Record Variance	Dimension Variances
-----------------	-----------	-----------------	------	-------	-----------------	---------------------

"mms4_asp2_tmod"	CDF_REAL4	1	0		T	
------------------	-----------	---	---	--	---	--

```
! VAR_COMPRESSION: GZIP.6
! (Valid compression: None, GZIP.1-9, RLE.0, HUFF.0, AHUFF.0)
! VAR_SPARSERECORDS: None
! (Valid sparserecords: None, sRecords.PAD, sRecords.PREV)
! VAR_PADVALUE: -1.0e+30
```

! Attribute Name	Data Type	Value
------------------	-----------	-------

```
"FIELDNAM" CDF_CHAR { "MOD Temperature" }
"LABLAXIS" CDF_CHAR { "T_mod" }
"UNITS" CDF_CHAR { "K (Celsius)" }
"CATDESC" CDF_CHAR { "ASPOC Module Temperature, 40s resolution" }
"VALIDMIN" CDF_REAL4 { -273.0 }
"VALIDMAX" CDF_REAL4 { 227.0 }
"SCALEMIN" CDF_REAL4 { 0.0 }
"SCALEMAX" CDF_REAL4 { 100.0 }
"FORMAT" CDF_CHAR { "F6.1" }
"FILLVAL" CDF_REAL4 { -1.0e+31 }
"VAR_TYPE" CDF_CHAR { "data" }
"SCALETYP" CDF_CHAR { "linear" }
"DEPEND_0" CDF_CHAR { "Epoch" }
"DISPLAY_TYPE" CDF_CHAR { "time_series" }
"DICTIONARY" CDF_CHAR { "temperature>mean_measured" }
"Frame" CDF_CHAR { "scalar>na" }
"SI_CONVERSION" CDF_CHAR { "1.0>K (Celsius)" }
"Sig_digits" CDF_CHAR { "4" }
"SC_id" CDF_CHAR { "4" } .
```

! RV values were not requested.

! Variable Name	Data Type	Number Elements	Dims	Sizes	Record Variance	Dimension Variances
-----------------	-----------	-----------------	------	-------	-----------------	---------------------

"mms4_asp2_stat"	CDF_UINT1	1	1	4	T	T
------------------	-----------	---	---	---	---	---

```
! VAR_COMPRESSION: GZIP.6
! (Valid compression: None, GZIP.1-9, RLE.0, HUFF.0, AHUFF.0)
! VAR_SPARSERECORDS: None
```



```
! (Valid sparserecords: None, sRecords.PAD, sRecords.PREV)
! VAR_PADVALUE: 255

! Attribute      Data
! Name          Type      Value
! -----
!
"FIELDNAM"      CDF_CHAR  { "Instrument Status" }
"LABLAXIS"      CDF_CHAR  { "S_inst" }
"UNITS"         CDF_CHAR  { " " }
"CATDESC"       CDF_CHAR  { "ASPOC Instrument Status, 40s resolution" }
"VALIDMIN"      CDF_UINT1 { 0 }
"VALIDMAX"      CDF_UINT1 { 254 }
"FORMAT"        CDF_CHAR  { "I3" }
"FILLVAL"       CDF_UINT1 { 255 }
"VAR_TYPE"      CDF_CHAR  { "data" }
"SCALETYP"      CDF_CHAR  { "linear" }
"DEPEND_0"      CDF_CHAR  { "Epoch" }
"DISPLAY_TYPE"  CDF_CHAR  { "time_series" }
"DICT_KEY"      CDF_CHAR  { "flag>status" }
"Frame"         CDF_CHAR  { "scalar>na" }
"SI_CONVERSION" CDF_CHAR  { " > " }
"Sig_digits"    CDF_CHAR  { "3" }
"SC_id"         CDF_CHAR  { "4" }
"DEPEND_1"      CDF_CHAR  { "mms4_asp2_lbl" }
"LABL_PTR_1"    CDF_CHAR  { "mms4_asp2_lbl" } .
```

! RV values were not requested.

Variable Name	Data Type	Number Elements	Dims	Sizes	Record Variance	Dimension Variances
"mms4_asp2_lbl"	CDF_CHAR	13	1	4	F	T

```
! VAR_COMPRESSION: None
! (Valid compression: None, GZIP.1-9, RLE.0, HUFF.0, AHUFF.0)
! VAR_SPARSERECORDS: None
! (Valid sparserecords: None, sRecords.PAD, sRecords.PREV)
! VAR_PADVALUE: " "
```

```
! Attribute      Data
! Name          Type      Value
! -----
!
"FIELDNAM"      CDF_CHAR  { "Status Labels" }
"LABLAXIS"      CDF_CHAR  { "lbl_status" }
"CATDESC"       CDF_CHAR  { "ASPOC Status Labels" }
"FORMAT"        CDF_CHAR  { "A21" }
"VAR_TYPE"      CDF_CHAR  { "metadata" } .
```

! NRV values follow...

```
[1] = { "Data Quality " }
[2] = { "Mode Settings" }
[3] = { "On/Off Status" }
[4] = { "Spare Byte  " }
```

Variable Name	Data Type	Number Elements	Dims	Sizes	Record Variance	Dimension Variances
"mms4_asp2_var"	CDF_REAL8	1	0		F	

```
! VAR_COMPRESSION: None
! (Valid compression: None, GZIP.1-9, RLE.0, HUFF.0, AHUFF.0)
! VAR_SPARSERECORDS: None
! (Valid sparserecords: None, sRecords.PAD, sRecords.PREV)
! VAR_PADVALUE: -1.0e+30
```

```
! Attribute      Data
```

! Name	Type	Value
! -----	----	-----
"FIELDNAM"	CDF_CHAR	{ "Half Interval" }
"LABLAXIS"	CDF_CHAR	{ "Half_int" }
"UNITS"	CDF_CHAR	{ "ns" }
"CATDESC"	CDF_CHAR	{ "Half with of measurement interval" }
"VALIDMIN"	CDF_REAL8	{ 0.0 }
"VALIDMAX"	CDF_REAL8	{ 1.275e+10 }
"FORMAT"	CDF_CHAR	{ "F13.1" }
"VAR_TYPE"	CDF_CHAR	{ "support_data" }
"SI_CONVERSION"	CDF_CHAR	{ "1.0e-9>s" } .
! NRV value follows...		
		[] = 5.0e+08
#end		

Table 2: L1B Status Data CDF Skeleton File

A.3. L2 Data CDF Skeleton File

```

! Skeleton table for the "mms2_aspoc_srvy_l2" CDF.
! Generated: Friday, 31-Jul-2015 15:47:53
! CDF created/modified by CDF V3.6.0
! Skeleton table created by CDF V3.6.0_4

#header

          CDF NAME: mms2_aspoc_srvy_l2
    DATA ENCODING: NETWORK
      MAJORITY: COLUMN
        FORMAT: SINGLE

! Variables  G.Attributes  V.Attributes  Records  Dims  Sizes
! -----
!          0/8           28           29           0/z           0

! CDF_COMPRESSION: None
! (Valid compression: None, GZIP.1-9, RLE.0, HUFF.0, AHUFF.0)
! CDF_CHECKSUM: MD5
! (Valid checksum: None, MD5)
! CDF_LEAPSECONDLASTUPDATED: 20150701

#GLOBALattributes

! Attribute      Entry      Data      Value
! Name           Number     Type       -----
! -----
"Project"        1:        CDF_CHAR  { "STP>Solar-Terrestrial Physics" } .
"Discipline"     1:        CDF_CHAR  { "Space Physics>" -
"                "Magnetospheric Science" } .
"Source_name"    1:        CDF_CHAR  { "MMS2>MMS Satellite Number 2" } .
"Data_type"      1:        CDF_CHAR  { "SRVY_L2>Level-2 Survey Data" } .
"Descriptor"     1:        CDF_CHAR  { "ASPOC>Active Spacecraft " -
"                Potential Control - " -
"                sensors 1 and 2" } .
"Data_version"   1:        CDF_CHAR  { "0.0.0" } .
"Generated_by"   1:        CDF_CHAR  { "Harald Jeszenszky @ IWF/OAW" } .
"Generation_date" 1:        CDF_CHAR  { "yyyymmdd" } .
"TITLE"          1:        CDF_CHAR  { "MMS ASPOC Beam Parameters" } .
"TEXT"           1:        CDF_CHAR  { "K. Torkar et al, Active " -
"                Spacecraft Potential " -
"                Control Investigation" }
                2:        CDF_CHAR  { "Space Science Reviews, 2014, " -
"                DOI: 10.1007/s11214-014-0049-3" }
                3:        CDF_CHAR  { "Further information:" }
                4:        CDF_CHAR  { "- " -
"                http://www.iwf.oeaw.ac.at/" -
"                en/research/near-earth-spa" -
"                ce/mms/" }
                5:        CDF_CHAR  { "- http://mms.space.swri.edu/" } .
"MODS"           1:        CDF_CHAR  { "150224 Initial version" }
                2:        CDF_CHAR  { "150831 Minor updates and fixes" }
                3:        CDF_CHAR  { "160205 CDF file format guide
compliant" } .
"Logical_file_id" 1:        CDF_CHAR  { "mms2_aspoc_srvy_l2_00000000" -
"                _v0.0.0" } .
"Logical_source" 1:        CDF_CHAR  { "mms2_aspoc_srvy_l2" } .

```

```

"Logical_source_description"
      1: CDF_CHAR { "Level 2 Active Spacecraft " -
                  "Potential Control Survey " -
                  "Data" } .

"PI_name"
      1: CDF_CHAR { "K. Torkar, R. Nakamura" } .

"PI_affiliation"
      1: CDF_CHAR { "IWF" } .

"Mission_group"
      1: CDF_CHAR { "MMS" } .

"Instrument_type"
      1: CDF_CHAR { "Spacecraft Potential Control" } .

"Acknowledgement"
      1: CDF_CHAR { "Refer to IWF/OAW for rules " -
                  " of acknowledgement" } .

"Skeleton_version"
      1: CDF_CHAR { "2.0" } .

"Software_version"
      1: CDF_CHAR { "Draft" } .

"Rules_of_use"
      1: CDF_CHAR { "Refer to IWF/OAW for rules of use"
} .

"Time_resolution"
      1: CDF_CHAR { "1 second" } .

"LINK_TITLE"
      1: CDF_CHAR { "AT GSFC" }
      2: CDF_CHAR { "AT SWRI" }
      3: CDF_CHAR { "LASP SDC" }
      4: CDF_CHAR { "MMS2 ASPOC" } .

"HTTP_LINK"
      1: CDF_CHAR { "http://mms.gsfc.nasa.gov/" }
      2: CDF_CHAR {
"http://mms.space.swri.edu/index.html" }
      3: CDF_CHAR { "https://lasp.colorado.edu/mms/sdc/" }
      4: CDF_CHAR {
"http://www.iwf.oeaw.ac.at/en/forschung/" -
"erdnaher-weltraum/mms/mms-as poc/" } .

"LINK_TEXT"
      1: CDF_CHAR { "MMS home page" }
      2: CDF_CHAR { "SMART package home page" }
      3: CDF_CHAR { "Science Data Center" }
      4: CDF_CHAR { "24-hour active spacecraft" -
                  " potential control data " -
                  "starting at dd Mon yyyy " -
                  "00:00 available at" } .

"File_naming_convention"
      1: CDF_CHAR { "source_descriptor_datatype" -
                  "_yyyyMMdd" } .

"ADID_ref" .

#VARIABLEattributes

"FIELDNAM"
"LABLAXIS"
"UNITS"
"CATDESC"
"DELTA_PLUS_VAR"
"DELTA_MINUS_VAR"
"VALIDMIN"
"VALIDMAX"
"SCALEMIN"
"SCALEMAX"
"FORMAT"
"FILLVAL"
"VAR_TYPE"
"SCALETYP"
"MONOTON"
"DEPEND_0"
"DISPLAY_TYPE"
"DICT_KEY"
"Frame"
"SI_CONVERSION"
"Sig digits"

```

```

"SC_id"
"VAR_NOTES"
"FORM_PTR"
"UNIT_PTR"
"SCAL_PTR"
"DEPEND_1"
"LABL_PTR_1"
"TIME_BASE"

#variables

! No rVariables.

#zVariables

! Variable          Data          Number          Record          Dimension
! Name             Type           Elements        Dims            Sizes           Variance        Variances
! -----

"Epoch"
          CDF_TIME_TT2000      1              0              T

! VAR_COMPRESSION: None
! (Valid compression: None, GZIP.1-9, RLE.0, HUFF.0, AHUFF.0)
! VAR_SPARSERECORDS: None
! (Valid sparserecords: None, sRecords.PAD, sRecords.PREV)
! VAR_PADVALUE: 0000-01-01T00:00:00.000000000

! Attribute          Data          Value
! Name              Type           -----
! -----

"FIELDNAM"          CDF_CHAR      { "Time tags" }
"LABLAXIS"          CDF_CHAR      { "Epoch" }
"UNITS"             CDF_CHAR      { "ns" }
"CATDESC"           CDF_CHAR      { "Interval centred time tag rounded to " -
                    "nearest msecond " }

"DELTA_PLUS_VAR"    CDF_CHAR      { "mms2_aspoc_var" }
"DELTA_MINUS_VAR"  CDF_CHAR      { "mms2_aspoc_var" }

"VALIDMIN"          CDF_TIME_TT2000 { 1990-01-01T00:00:00.000000000 }
"VALIDMAX"          CDF_TIME_TT2000 { 2100-01-01T00:00:00.000000000 }
"SCALEMIN"          CDF_TIME_TT2000 { 1990-01-01T00:00:00.000000000 }
"SCALEMAX"          CDF_TIME_TT2000 { 2100-01-01T00:00:00.000000000 }
"FILLVAL"           CDF_TIME_TT2000 { 9999-12-31T23:59:59.999999999 }
"VAR_TYPE"          CDF_CHAR      { "data" }
"SCALETYP"          CDF_CHAR      { "linear" }
"MONOTON"           CDF_CHAR      { "INCREASE" }
"DISPLAY_TYPE"      CDF_CHAR      { "time_series" }
"DICT_KEY"           CDF_CHAR      { "time>epoch" }
"Frame"             CDF_CHAR      { "scalar>na" }
"SI_CONVERSION"     CDF_CHAR      { "1.0e-9>s" }
"Sig_digits"        CDF_CHAR      { "14" }
"SC_id"             CDF_CHAR      { "2" }
"TIME_BASE"         CDF_CHAR      { "J2000" } .

! RV values were not requested.

! Variable          Data          Number          Record          Dimension
! Name             Type           Elements        Dims            Sizes           Variance        Variances
! -----

"mms2_aspoc_ionc"
          CDF_REAL4          1              0              T

! VAR_COMPRESSION: GZIP.6
! (Valid compression: None, GZIP.1-9, RLE.0, HUFF.0, AHUFF.0)

```

```

! VAR_SPARSERECORDS: None
! (Valid sparserecords: None, sRecords.PAD, sRecords.PREV)
! VAR_PADVALUE: -1.0e+30

! Attribute      Data
! Name           Type      Value
! -----
"FIELDNAM"      CDF_CHAR { "Beam Current" }
"LABLAXIS"      CDF_CHAR { "I_ion" }
"UNITS"         CDF_CHAR { "uA" }
"CATDESC"       CDF_CHAR { "ASPOC Ion Emission Current Sum, " -
"1s resolution" }
"VALIDMIN"      CDF_REAL4 { 0.0 }
"VALIDMAX"      CDF_REAL4 { 100.0 }
"SCALEMIN"      CDF_REAL4 { 0.0 }
"SCALEMAX"      CDF_REAL4 { 100.0 }
"FORMAT"        CDF_CHAR { "F5.1" }
"FILLVAL"       CDF_REAL4 { -1.0e+31 }
"VAR_TYPE"      CDF_CHAR { "data" }
"SCALETYP"      CDF_CHAR { "linear" }
"DEPEND_0"      CDF_CHAR { "Epoch" }
"DISPLAY_TYPE"  CDF_CHAR { "time_series" }
"DICT_KEY"      CDF_CHAR { "current>mean_measured" }
"Frame"         CDF_CHAR { "scalar>na" }
"SI_CONVERSION" CDF_CHAR { "1.0e-6>A" }
"Sig_digits"    CDF_CHAR { "4" }
"SC_id"         CDF_CHAR { "2" } .

! RV values were not requested.

! Variable      Data      Number      Record      Dimension
! Name          Type      Elements    Dims      Sizes      Variance    Variances
! -----
"mms2_aspl_ionc"
                        CDF_REAL4      1          0          T

! VAR_COMPRESSION: GZIP.6
! (Valid compression: None, GZIP.1-9, RLE.0, HUFF.0, AHUFF.0)
! VAR_SPARSERECORDS: None
! (Valid sparserecords: None, sRecords.PAD, sRecords.PREV)
! VAR_PADVALUE: -1.0e+30

! Attribute      Data
! Name           Type      Value
! -----
"FIELDNAM"      CDF_CHAR { "Beam Current" }
"LABLAXIS"      CDF_CHAR { "I_ion" }
"UNITS"         CDF_CHAR { "uA" }
"CATDESC"       CDF_CHAR { "ASPOC Unit 1 Ion Emission Current, " -
"1s resolution" }
"VALIDMIN"      CDF_REAL4 { 0.0 }
"VALIDMAX"      CDF_REAL4 { 100.0 }
"SCALEMIN"      CDF_REAL4 { 0.0 }
"SCALEMAX"      CDF_REAL4 { 100.0 }
"FORMAT"        CDF_CHAR { "F5.1" }
"FILLVAL"       CDF_REAL4 { -1.0e+31 }
"VAR_TYPE"      CDF_CHAR { "data" }
"SCALETYP"      CDF_CHAR { "linear" }
"DEPEND_0"      CDF_CHAR { "Epoch" }
"DISPLAY_TYPE"  CDF_CHAR { "time_series" }
"DICT_KEY"      CDF_CHAR { "current>mean_measured" }
"Frame"         CDF_CHAR { "scalar>na" }
"SI_CONVERSION" CDF_CHAR { "1.0e-6>A" }
"Sig_digits"    CDF_CHAR { "4" }
"SC_id"         CDF_CHAR { "2" } .

! RV values were not requested.

```

```

! Variable      Data      Number      Record      Dimension
! Name          Type      Elements    Dims        Sizes        Variance    Variances
! -----
!
"mms2_asp2_ionc"
      CDF_REAL4      1      0      T

! VAR_COMPRESSION: GZIP.6
! (Valid compression: None, GZIP.1-9, RLE.0, HUFF.0, AHUFF.0)
! VAR_SPARSERECORDS: None
! (Valid sparserecords: None, sRecords.PAD, sRecords.PREV)
! VAR_PADVALUE: -1.0e+30

! Attribute      Data
! Name          Type      Value
! -----
!
"FIELDNAM"      CDF_CHAR      { "Beam Current" }
"LABLAXIS"      CDF_CHAR      { "I_ion" }
"UNITS"         CDF_CHAR      { "uA" }
"CATDESC"       CDF_CHAR      { "ASPOC Unit 2 Ion Emission Current, " -
      "1s resolution" }
"VALIDMIN"      CDF_REAL4     { 0.0 }
"VALIDMAX"      CDF_REAL4     { 100.0 }
"SCALEMIN"      CDF_REAL4     { 0.0 }
"SCALEMAX"      CDF_REAL4     { 100.0 }
"FORMAT"        CDF_CHAR      { "F5.1" }
"FILLVAL"       CDF_REAL4     { -1.0e+31 }
"VAR_TYPE"      CDF_CHAR      { "data" }
"SCALETYP"      CDF_CHAR      { "linear" }
"DEPEND_0"      CDF_CHAR      { "Epoch" }
"DISPLAY_TYPE"  CDF_CHAR      { "time_series" }
"DICT_KEY"      CDF_CHAR      { "current>mean_measured" }
"Frame"         CDF_CHAR      { "scalar>na" }
"SI_CONVERSION" CDF_CHAR      { "1.0e-6>A" }
"Sig_digits"    CDF_CHAR      { "4" }
"SC_id"         CDF_CHAR      { "2" } .

! RV values were not requested.

! Variable      Data      Number      Record      Dimension
! Name          Type      Elements    Dims        Sizes        Variance    Variances
! -----
!
"mms2_asp1_energy"
      CDF_REAL4      1      0      T

! VAR_COMPRESSION: GZIP.6
! (Valid compression: None, GZIP.1-9, RLE.0, HUFF.0, AHUFF.0)
! VAR_SPARSERECORDS: None
! (Valid sparserecords: None, sRecords.PAD, sRecords.PREV)
! VAR_PADVALUE: -1.0e+30

! Attribute      Data
! Name          Type      Value
! -----
!
"FIELDNAM"      CDF_CHAR      { "Beam Energy" }
"LABLAXIS"      CDF_CHAR      { "Energy" }
"UNITS"         CDF_CHAR      { "kV" }
"CATDESC"       CDF_CHAR      { "ASPOC Unit 1 Emitted Beam Energy, " -
      "1s resolution" }
"VALIDMIN"      CDF_REAL4     { 0.0 }
"VALIDMAX"      CDF_REAL4     { 12.5 }
"SCALEMIN"      CDF_REAL4     { 0.0 }
"SCALEMAX"      CDF_REAL4     { 12.5 }
"FORMAT"        CDF_CHAR      { "F5.2" }
"FILLVAL"       CDF_REAL4     { -1.0e+31 }
"VAR_TYPE"      CDF_CHAR      { "data" }
"SCALETYP"      CDF_CHAR      { "linear" }
"DEPEND_0"      CDF_CHAR      { "Epoch" }
"DISPLAY_TYPE"  CDF_CHAR      { "time_series" }

```

```

"DICT_KEY" CDF_CHAR { "energy>mean_measured" }
"Frame" CDF_CHAR { "scalar>na" }
"SI_CONVERSION" CDF_CHAR { "1.0e3>V" }
"Sig_digits" CDF_CHAR { "4" }
"SC_id" CDF_CHAR { "2" } .

! RV values were not requested.

! Variable Data Number Record Dimension
! Name Type Elements Dims Sizes Variance Variances
! -----
"mms2_asp2_energy"
CDF_REAL4 1 0 T

! VAR_COMPRESSION: GZIP.6
! (Valid compression: None, GZIP.1-9, RLE.0, HUFF.0, AHUFF.0)
! VAR_SPARSERECORDS: None
! (Valid sparserecords: None, sRecords.PAD, sRecords.PREV)
! VAR_PADVALUE: -1.0e+30

! Attribute Data Value
! Name Type Value
! -----
"FIELDNAM" CDF_CHAR { "Beam Energy" }
"LABLAXIS" CDF_CHAR { "Energy" }
"UNITS" CDF_CHAR { "kV" }
"CATDESC" CDF_CHAR { "ASPOC Unit 2 Emitted Beam Energy, " -
"1s resolution" }
"VALIDMIN" CDF_REAL4 { 0.0 }
"VALIDMAX" CDF_REAL4 { 12.5 }
"SCALEMIN" CDF_REAL4 { 0.0 }
"SCALEMAX" CDF_REAL4 { 12.5 }
"FORMAT" CDF_CHAR { "F5.2" }
"FILLVAL" CDF_REAL4 { -1.0e+31 }
"VAR_TYPE" CDF_CHAR { "data" }
"SCALETYP" CDF_CHAR { "linear" }
"DEPEND_0" CDF_CHAR { "Epoch" }
"DISPLAY_TYPE" CDF_CHAR { "time_series" }
"DICT_KEY" CDF_CHAR { "energy>mean_measured" }
"Frame" CDF_CHAR { "scalar>na" }
"SI_CONVERSION" CDF_CHAR { "1.0e3>V" }
"Sig_digits" CDF_CHAR { "4" }
"SC_id" CDF_CHAR { "2" } .

! RV values were not requested.

! Variable Data Number Record Dimension
! Name Type Elements Dims Sizes Variance Variances
! -----
"mms2_aspoc_status"
CDF_UINT1 1 1 4 T T

! VAR_COMPRESSION: GZIP.6
! (Valid compression: None, GZIP.1-9, RLE.0, HUFF.0, AHUFF.0)
! VAR_SPARSERECORDS: None
! (Valid sparserecords: None, sRecords.PAD, sRecords.PREV)
! VAR_PADVALUE: 255

! Attribute Data Value
! Name Type Value
! -----
"FIELDNAM" CDF_CHAR { "Instrument Status" }
"LABLAXIS" CDF_CHAR { "Status" }
"UNITS" CDF_CHAR { " " }
"CATDESC" CDF_CHAR { "ASPOC Instrument Status, 1s resolution" }
"VALIDMIN" CDF_UINT1 { 0 }
"VALIDMAX" CDF_UINT1 { 254 }
"FORMAT" CDF_CHAR { "I3" }

```



```

"FiLLVAL" CDF_UINT1 { 255 }
"VAR_TYPE" CDF_CHAR { "data" }
"SCALE_Typ" CDF_CHAR { "linear" }
"DEPEND_0" CDF_CHAR { "Epoch" }
"DISPLAY_TYPE"
  CDF_CHAR { "time_series" }
"DICT_KEY" CDF_CHAR { "flag>status" }
"Frame" CDF_CHAR { "scalar>na" }
"SI_CONVERSION"
  CDF_CHAR { " > " }
"Sig_digits" CDF_CHAR { "3" }
"SC_id" CDF_CHAR { "2" }
"DEPEND_1" CDF_CHAR { "mms2_aspoc_lbl" }
"LABL_PTR_1" CDF_CHAR { "mms2_aspoc_lbl" } .

! RV values were not requested.

! Variable      Data      Number      Record      Dimension
! Name          Type      Elements    Dims      Sizes      Variance    Variances
! -----
"mms2_aspoc_lbl" CDF_CHAR      13          1          4          F          T

! VAR_COMPRESSION: None
! (Valid compression: None, GZIP.1-9, RLE.0, HUFF.0, AHUFF.0)
! VAR_SPARSERECORDS: None
! (Valid sparserecords: None, sRecords.PAD, sRecords.PREV)
! VAR_PADVALUE: " "

! Attribute      Data      Value
! Name           Type      -----
"FIELDNAM"      CDF_CHAR { "Status Labels" }
"LABLAXIS"      CDF_CHAR { "lbl_status" }
"CATDESC"       CDF_CHAR { "Labels for Instrument Status" }
"FORMAT"        CDF_CHAR { "A14" }
"VAR_TYPE"      CDF_CHAR { "metadata" } .

! NRV values follow...

[1] = { "Data Quality " }
[2] = { "Unit 1 Mode " }
[3] = { "Unit 2 Mode " }
[4] = { "On/Off Status" }

! Variable      Data      Number      Record      Dimension
! Name          Type      Elements    Dims      Sizes      Variance    Variances
! -----
"mms2_aspoc_var"
  CDF_REAL8      1          0          F

! VAR_COMPRESSION: None
! (Valid compression: None, GZIP.1-9, RLE.0, HUFF.0, AHUFF.0)
! VAR_SPARSERECORDS: None
! (Valid sparserecords: None, sRecords.PAD, sRecords.PREV)
! VAR_PADVALUE: -1.0e+30

! Attribute      Data      Value
! Name           Type      -----
"FIELDNAM"      CDF_CHAR { "Half Interval" }
"LABLAXIS"      CDF_CHAR { "Half_int" }
"UNITS"         CDF_CHAR { "ns" }
"CATDESC"       CDF_CHAR { "Half with of measurement interval" }
"VALIDMIN"      CDF_REAL8 { 0.0 }
"VALIDMAX"      CDF_REAL8 { 1.275e+10 }
"FORMAT"        CDF_CHAR { "F13.1" }
"VAR_TYPE"      CDF_CHAR { "support_data" }
"SI_CONVERSION"
  CDF_CHAR { "1.0e-9>s" } .

! NRV value follows...

```

```
[ ] = 5.0e+08  
#end
```

Table 3: L2 Data CDF Skeleton File