

25.4 mm  
1 inch

REVISIONS			
REV.	DESCRIPTION	DATE	APPROVED
A	BASELINE RELEASE	11/3/97	

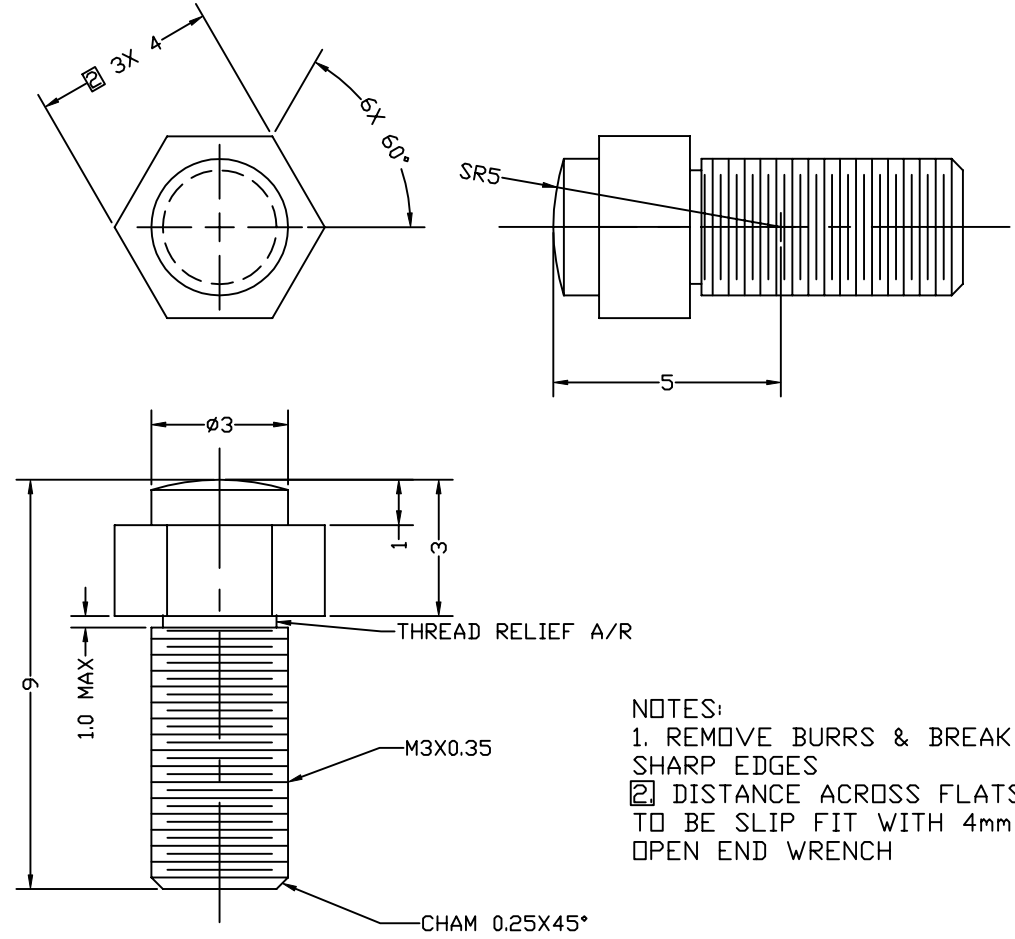

NOTES:  
 1. REMOVE BURRS & BREAK SHARP EDGES  
 2. DISTANCE ACROSS FLATS TO BE SLIP FIT WITH 4mm OPEN END WRENCH

1	A/R	C544 PHOSPHOR BRONZE	
ITEM#	QTY	PART NUMBER	NOMENCLATURE
TOLERANCES (EXCEPT AS SPECIFIED)		DO NOT SCALE DRAWING METRIC DRAWING (UNITS: mm)	
OVER	TO	TOLERANCE	INTERPRET PER ANSI Y14.5-1994 WELDING SYMBOLS PER ANSI/AWS A2.4-79
0	49.99	±0.1	
50	249.9	±0.5	APPROVALS
250	-	±1	
ANGLES		±1°	DATE
SURFACE FINISH		0.8	
SURFACE TREATMENT		NONE	
MASS			
DWG TITLE		XY ADJUSTER SCREW FUV WIC DETECTOR MOUNT	
SIZE	PROGRAM	DWG. NO.	REV
A	IMAGE	8173-A4	A
SCALE 8:1		SHEET 1 OF 1	

Space Sciences Laboratory  
UNIVERSITY OF CALIFORNIA, BERKELEY, USA

DRAWN K. KROMER 11/3/97