

REVISIONS			
REV.	DESCRIPTION	DATE	APPROVED
C	REMOVED EARS & 8X THRU HOLES, ADDED Ø63.3 FLANGE	3/10/98	

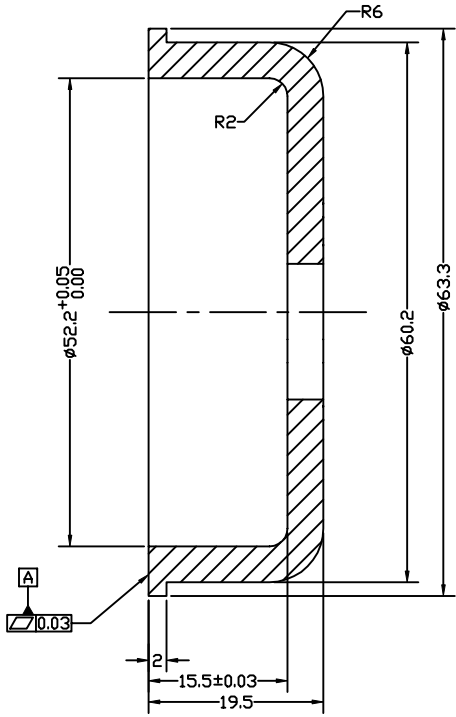

4X DRILL & TAP  
THRU FOR M2X0.4,  
CSK Ø2.4X90° MIN  
Ø0.15 @ AB

- NOTES, UNLESS SPECIFIED OTHERWISE:
1. REMOVE BURRS & BREAK SHARP EDGES
  2. IDENTIFY PART BY BAGGING AND TAGGING
  3. MATERIAL CERTS REQUIRED

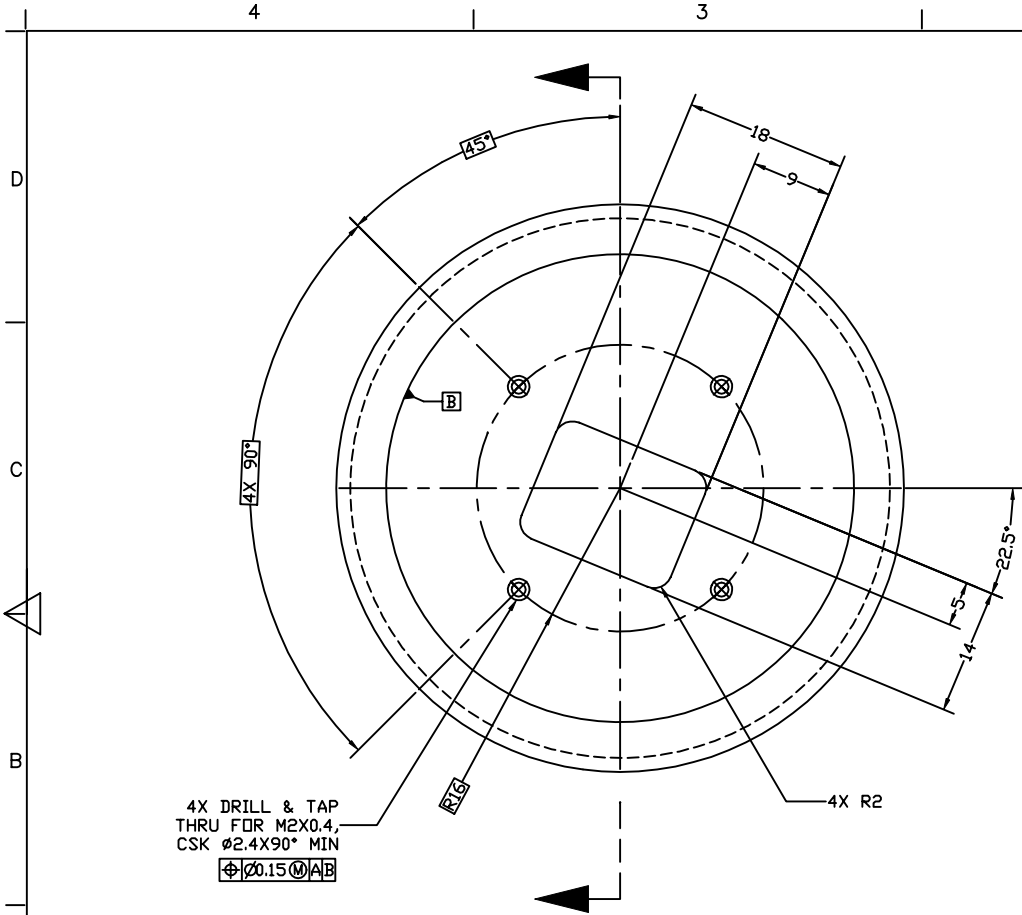
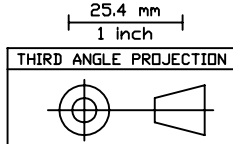

1	A/R	TANTALUM		
ITEM#	QTY	PART NUMBER	NOMENCLATURE	MATERIAL SPECIFICATION
TOLERANCES (EXCEPT AS SPECIFIED)		DO NOT SCALE DRAWING METRIC DRAWING (UNITS: mm)		<i>Space Sciences Laboratory</i> UNIVERSITY OF CALIFORNIA, BERKELEY, USA
OVER	TD	TOLERANCE	INTERPRET PER ANSI Y14.5-1994 WELDING SYMBOLS PER ANSI/ASME A2.4-79	
0	49.99	±0.1	APPROVALS	DWG TITLE
20	249.9	±0.5	DATE	OUTER CCD SHIELD
250	-	±1	DRAWN K. KROMER 11/19/97	FUV WIC
ANGLES		±1°	CHECKED	SIZE B
SURFACE FINISH		1.6	ISSUED	PROGRAM IMAGE
SURFACE TREATMENT		NONE	SCALE 2:1	DWG. NO. 8147-A4
MASS		342.8g		REV C
				SHEET 1 OF 1