

REVISIONS			
	DESCRIPTION	DATE	APPROVED
A	BASELINE RELEASE	9/21/97	

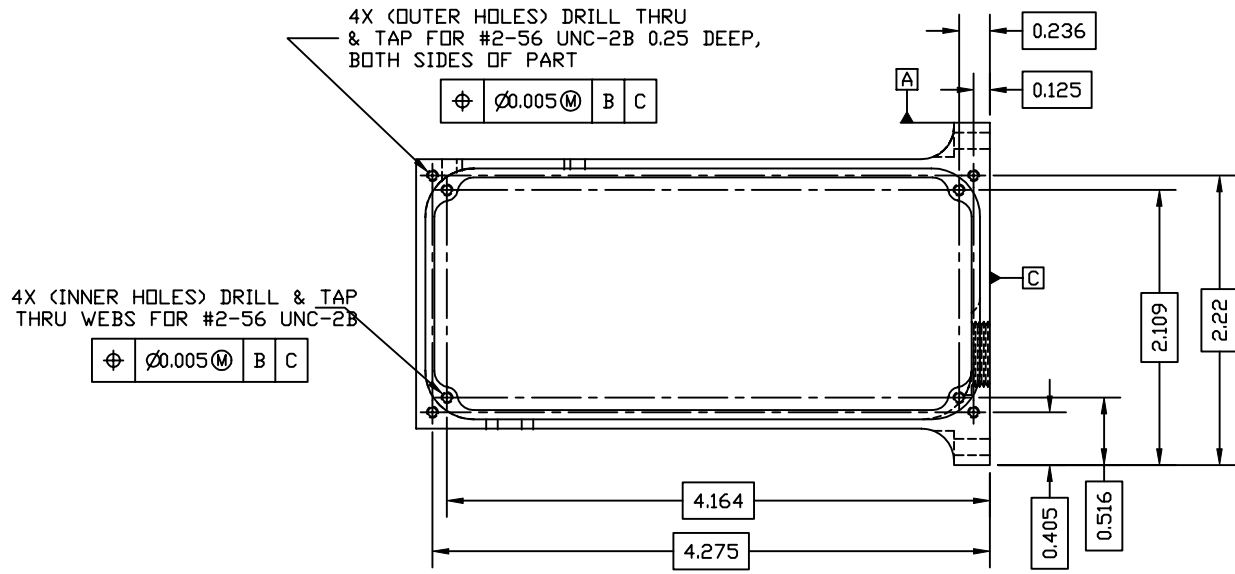

VIEW B-B

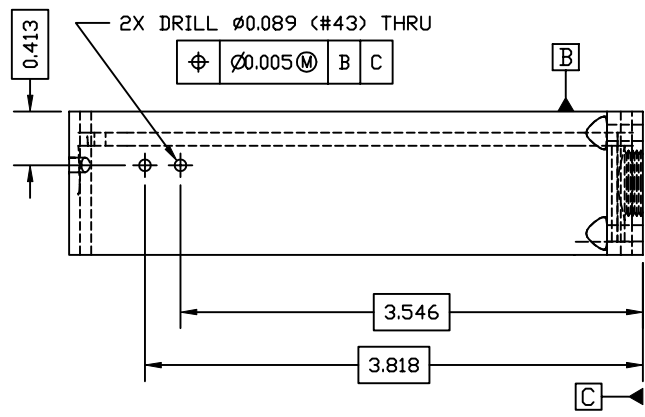

DRILL & TAP THRU FOR 1/2-32 UN-2B  
SPOTFACE Ø0.625 UNTIL  
REMAINING MATERIAL IS 0.140 THICK

Ø0.005 M A B

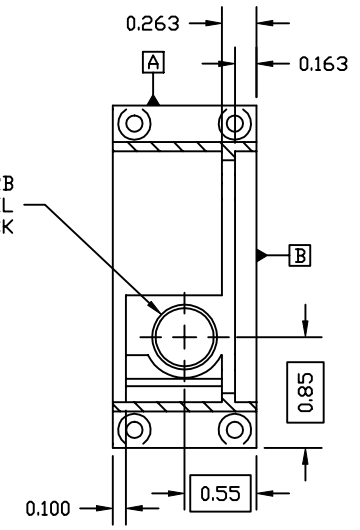

SECTION A-A

SIZE <b>B</b>	PROGRAM IMAGE	DWG. NO. 8086-A4	REV A
SCALE FULL		SHEET 2 OF 2	