

VIEW A-A

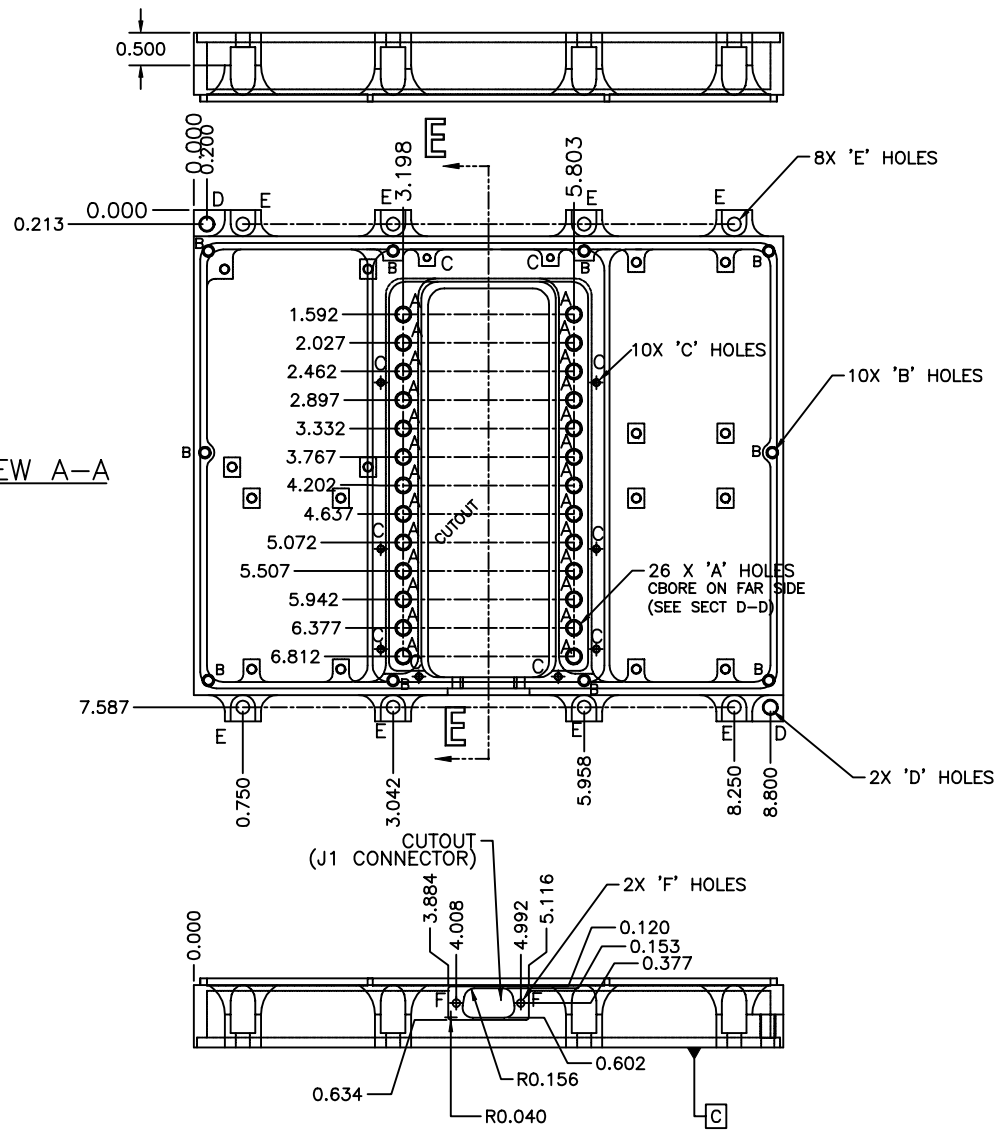

SECTION E-E

HOLE SCHEDULE

ALL HOLES POSITION $\pm \phi .005$ A | B | C

HOLE	DESCRIPTION
A	1/4-28 UNC 2B THRU CBORE $\phi .25$ X .050 DEEP
B	DRILL #26 THRU TAP FOR 6-32 HELICOIL X .20 DEEP
C	TAP 2-56 UNC-2B THRU
D	TAP THRU FOR 10-32 HELICOIL
E	DRILL $\phi .201$ THRU CBORE $\phi .375$ AS SHOWN TO LEAVE .20 MATL
F	TAP 4-40 THRU
G	DRILL #26 THRU TAP FOR 6-32 HELICOIL X .20 DEEP
H	TAP FOR 2-56 HELICOIL X .17 DEEP

SIZE	FSCM NO.	DWG NO.	8015-A4	REV	C
SCALE 1/2		SHEET		2 OF 2	