

Laboratoire de Physique et Chimie de l'Environnement

CLUSTER II WEC 9.1

WHISPER

Internal EID

CONTENTS

	Page
Documentation change record.....	1
List of accronyms.....	3
I Power up and starting WHISPER.....	4
II WHISPER Commanding.....	5
II-1 WHISPER Command Mode Word (WCMW).....	5
Modes definition (mode).....	6
FFT size - Data block size (fft_size).....	6
Repetition factor (rep_fac).....	6
Emis./Rec. Rate, Nb of averaged spectra (smode_aver).....	7
WHISPER processing modes (whi_process).....	9
WHISPER internal processing dedicated modes.....	10
Pulse duration (PULSE).....	12
Emission (level).....	12
Gain command (gain_cmd).....	13
Auto Gain Threshold/Dump acq-memory (gain_thres/dump_mem).....	13
Receiver Connection (E_Signal).....	14
Frequency point, Frequency Range (fst).....	14
II-2 Data Post-Processing.....	15
DWP processing WHISPER Processing Word (WPW).....	15
II-3 WHISPER default command (internal DWP).....	19
II-4 Contingency modes.....	20
Contingency mode 1 (Natural Waves).....	20
Contingency mode 2 (Sounding).....	20
II-5 Uploading and protect/unprotect S/W (ground operation).....	21
II-6 Calibration modes.....	22
Calibration 1 mode (Quiet).....	22
Calibration 2 mode (Sounding).....	22
Calibration 1 whi_pro (Quiet).....	23
Calibration 2 whi_pro (Sounding).....	23
II-7 Troubleshooting modes.....	26
Acquisition Dump mode.....	26
Programme Memories Dump modes.....	26
WHISPER Do Nothing mode.....	26
WHISPER ALARME mode.....	26
II-8 File naming & examples of some valid commands.....	27
III OUTPUT DATA FORMAT.....	29
III-1 General.....	29
III-2 Housekeeping Data.....	30
III-3 WHISPER Actual Mode Words (WAMW) Status.....	31
Status word 0 (identifier step_row).....	31
Status Word 1 (E_Signal - vsp-scale).....	31
Status Word 2 (overf2 - gainmode2).....	32
Status Word 3 (wd2_rec2_row2).....	33
III-4 WHISPER Command Mode Word (WCMW) status.....	34
Status Word 4 (WCMW0-WCMW1).....	34
Status word 5 (WCMW2-frequency2).....	34

III-5	WHISPER Data Main Words (WDMW)	41
III-6	WHISPER Uploading EEPROM and protect/unprotect Status	42
III-7	WHISPER Processed Calibration Mode Words Status	44
III-8	WHISPER internal processing dedicated modes output format	46
III-9	WHISPER Trouble shooting Mode Words (WTMW) Status	47
	Acquisition Dump Mode Words Status	47
	Programme Dump Mode Words Status	48
III-10	Output data frame	49
IV	Sounding Frequency Tables	60
IV-1	Sounding frequency (kHz) vs frequency step number N	60
IV-2	Frequency Scan Tables (fst)	61
	fst encoding	61
	Frequency Scan Tables (algorithm for standard tables)	62
	WHISPER frequency scan table "fst"	63
	Frequency Scan Tables fixed tables (special sweeps)	66
	Format of the fixed frequency table	67
	Frequency Scan Tables fixed tables (calibrations)	75
	Frequency Swept Operations(sounding)	76
V	WHISPER internal tables and mapping	108
V-1	Windowing Coefficients Table (Blackman-Harris) 16 bit	108
V-2	Synthesizer Prom table	112
V-3	Micro-Controller mapping	114
V-4	Micro-Controller Internal RAM mapping	115
V-5	Micro-Controller BIT addressable register area	116
V-6	VSP mapping	117
V-7	ZORAN internal memory and register mapping	118
VI	Connector pin Assignment	119
VI.1	J01 Power interface	119
VI.2	J02 Transmitter data link	119
VI.3	J03 Receiver data link	119
VI.4	J04 DWP interface	120
VI.5	J05 HVC interface and TEST	120
VII	Short Forms for commanding & Status	121
VIII	Short Form for Data Analysis	123

Documentation change record

Issue	Rev.	Chap.	Para.	Date	Changes
5	2	all		July 90	Basic for EM
6	0	all		Oct 91	internal only, not distributed
7	2	all		Nov 91	proposal for modifications
7	3	II	all	Jan 92	new patern of WCMW
		III	1 - 7	"	changes with new WCMW
		III	8	"	output data frame reduced by
		IX		"	internal calculation of moduli
7	4	I		17/01/92	new mechanical drawing
		II	1	"	setup diagramm updated
		II	4	"	repetition factor 1 for N mode
		III	1	"	calibration modes frequencies
				"	" duration
		III	1	"	setup status deleted
				"	end status deleted
				"	new identifier definition including
				"	a process mode and step row
		III	2	"	new table "WHISPER HK / WEC HK"
		III	3	"	new ID definition
				"	step row definition
				"	status word 3
				"	new row number definition
				"	new listen sequence number
				"	status word 4 byte 1
				"	according to new repetition fac
		III	6	"	"c" calibration points updated
7		III	3	10/02/92	new identifier deleted only "w"
7		II	1	12/02/92	alternate mode deleted
		III	3	"	row definition corrected
		III	4	"	alternate mode status deleted
7		III	6	28/02/92	New Troubleshooting mode status
7		II	1	02/03/92	acq_dump command changed
7	5	II	4	16/03/92	definition of calibration whi_pro
		II	5	"	updating troubleshooting modes
		III	6	"	definition of status for cal whi_pro
7	5	II	1	21/03/92	dump mode frames at 64 words
7	5	I		03/04/92	power up and starting updated
		II	1	"	new tracking mode WHISPER processed
		II	3	"	new upload command in mode 1
		III	6	"	status for uploading EEPROM
7	6	II	2	03/08/92	Data Post-Processing definition
		II	4	"	new contingency 1 mode
7	6	II	1	12/11/92	rep fac 12 to 232 in nat mode
		III	4	"	idem
7	7	II	1	08/12/92	emission/reception rate updated
		III	4	"	idem
		II	2	"	post processing updated
		II	1	"	WHISPER internal processing added
		III	8	"	Watch dog status added in dump modes
		II	5	17/01/93	Software protection command added
		III	6	"	idem
7	8	IV	2	19/05/93	New frequency fixed tables and
					new frequency scan tables.
		II	1		Default Gain Threshold = 2, modulo 1
7	8	II	7	28/05/93	New Do Nothing and Alarme Commands
7	9	III	9	15/10/93	Update of Output frame for 128 bins

Issue	Rev.	Chap.	Para.	Date	Changes
7	10	all		20/04/94	editorial
7	10	III	9	22/04/94	description of output format for the internal processed modes
7	10	II	1	02/05/94	typing errors corrected p 11
		II	6	"	typing errors corrected p 24 & 25
		II	7	"	typing errors corrected p 26
		VII		"	short form corrected
8	0	all		01/08/96	new issue for PHOENIX
9	0	all		25/02/98	new issue for CLUSTER 2
		II	1		Command Mode words
					New Sync and Gliding modes
					New Internal dedicated sounding mode with listen delayed
					New use of the PULSE parameter associated with the Fix tables of the FST sets the sounding mode with the first listen delayed.
					Three gain levels instead of four.
					New switchable connection to Ez (default) or Ey and thus new pattern for gain threshold and dump modes.
		II	2		New contingency modes.
		II	6		New calibration table.
		II	7		New pattern for dump commands.
		II	8		New file naming for factory tests.
		III	3		New status for Ez-Ey connection.
					New status for listen delayed.
					New status for slice of FST .
		III	4		New status pattern for gain.
					New status pattern for word 5
		III	9		New status pattern for word 4 byte0
		III	10		New status pattern for dump modes.
		IV	2		Output frame for 128 bin rescaled.
		V	2		New fix tables in FST.
		V	3		New micro-Ctrlr mapping.
		V	6		New VSP mapping.
		VI	3		New pin allocation for J03.
9	1	IV	2	03/06/98	Modifications of fixed frequency. tables 8 (fst47) and 9 (fst 58)
		IV	2		Clarification for frequency swept operations.

List of accronyms

- ADC : Analog to Digital Converter
- AIV Program : Assembly and Interface Verification Program
- AIT : Assembly Integration and Tests
- CNRS : Centre National de la Recherche Scientifique
- DWP : Digital Wave Processing experiment
- EFW : Electric Field and Waves experiment
- EGSE : Electrical Ground Support Equipment
- ESA : European Space Agency
- FFT : Fast Fourier Transform
- GSE : Ground Support Equipment
- LPCE : Laboratoire de Physique et Chimie de l'Environnement
- M-C : Micro-Controller
- PC : Personal Computer
- PWR : WEC Power Supply
- VSP : Vector Signal Processor
- WAMW : WHISPER Actual Mode Word
- WCMW : WHISPER Command Mode Word
- WPW : WHISPER Processing Word
- WEC : Wave Experiment Consortium
- WHISPER : Waves of High frequencies and Sounder for Probing of Electron density by Relaxation

I Power up and starting WHISPER

From DWP

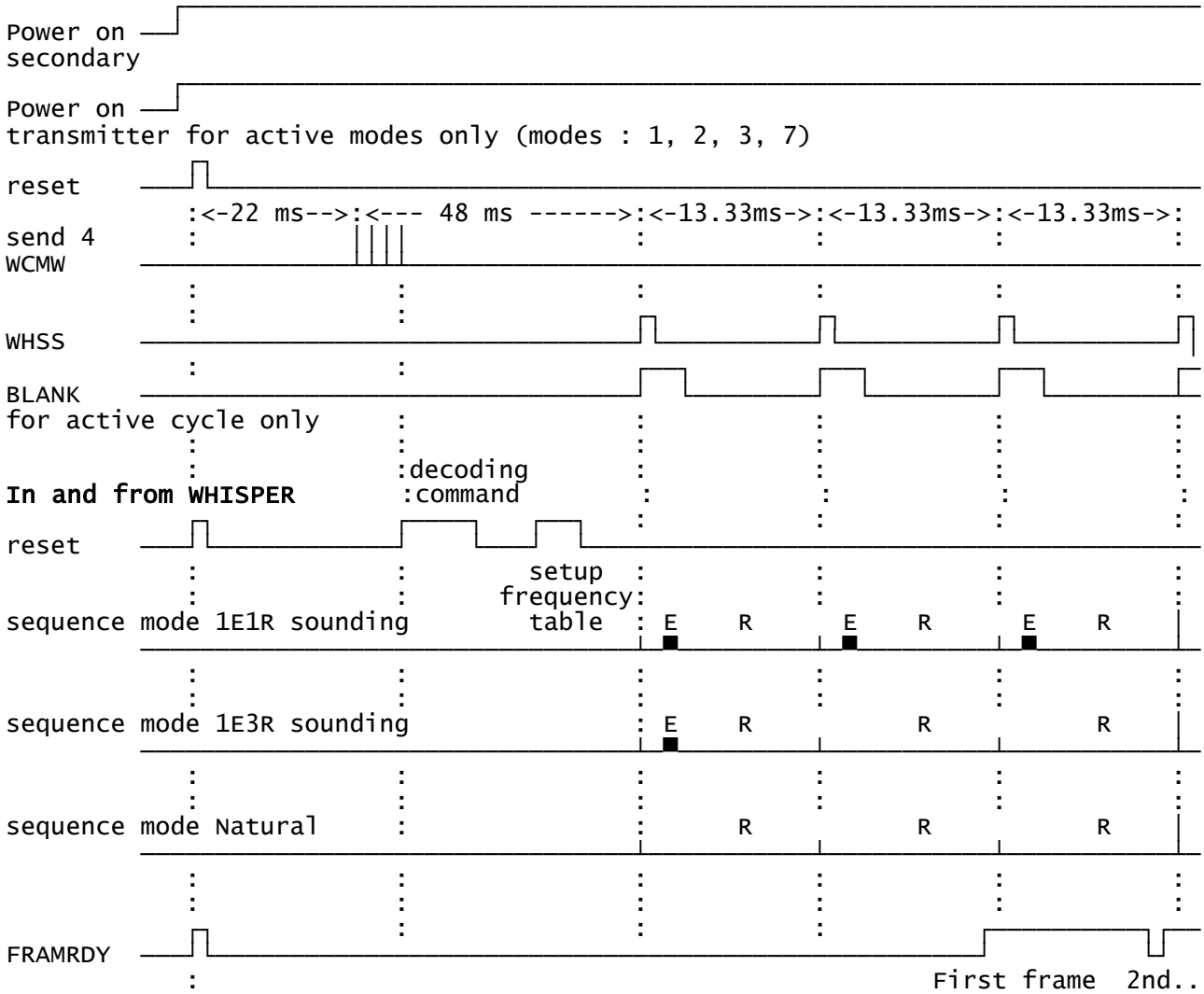

II WHISPER Commanding

II-1 WHISPER Command Mode word (WCMW)

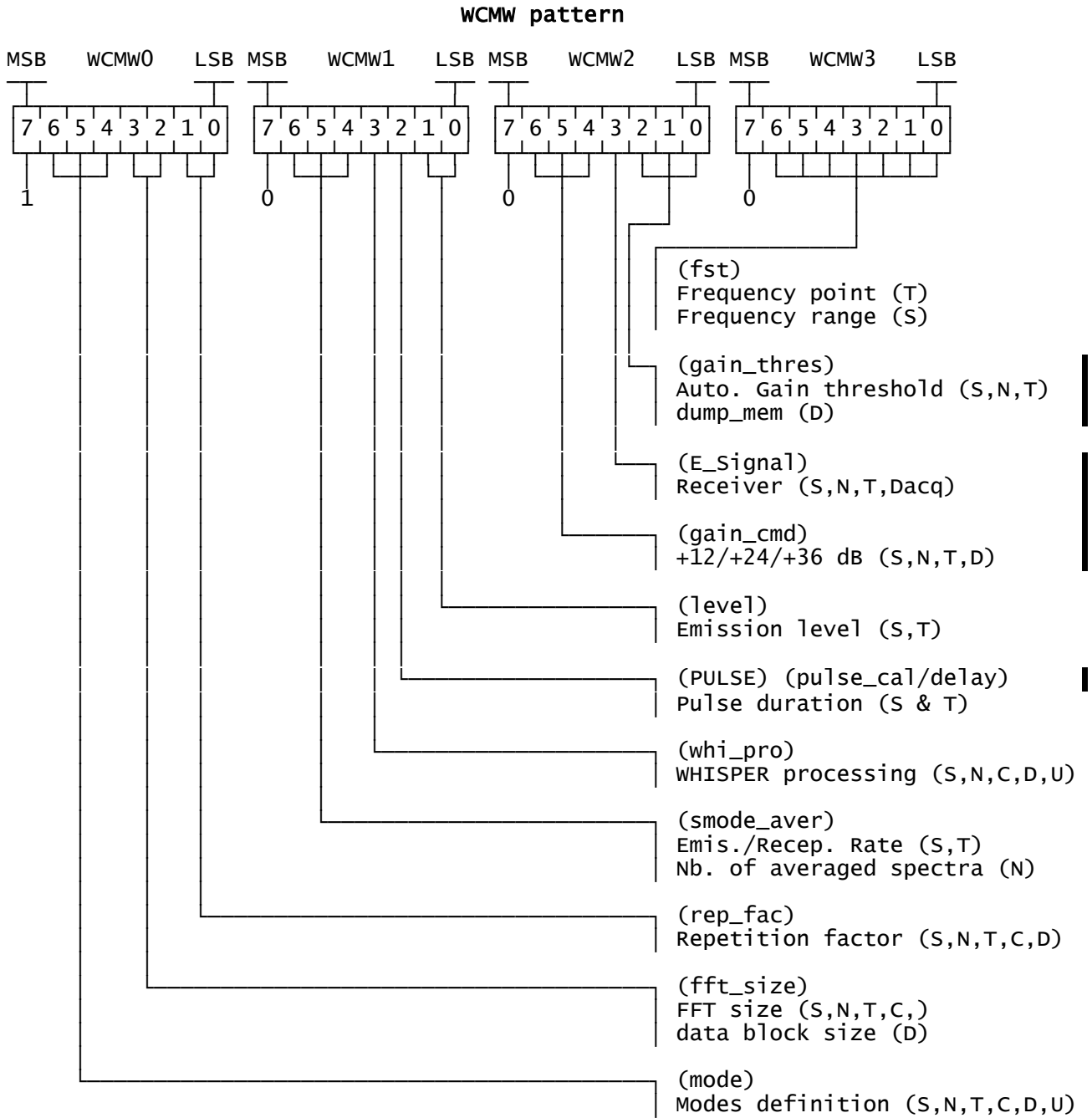

Modes definition (mode)

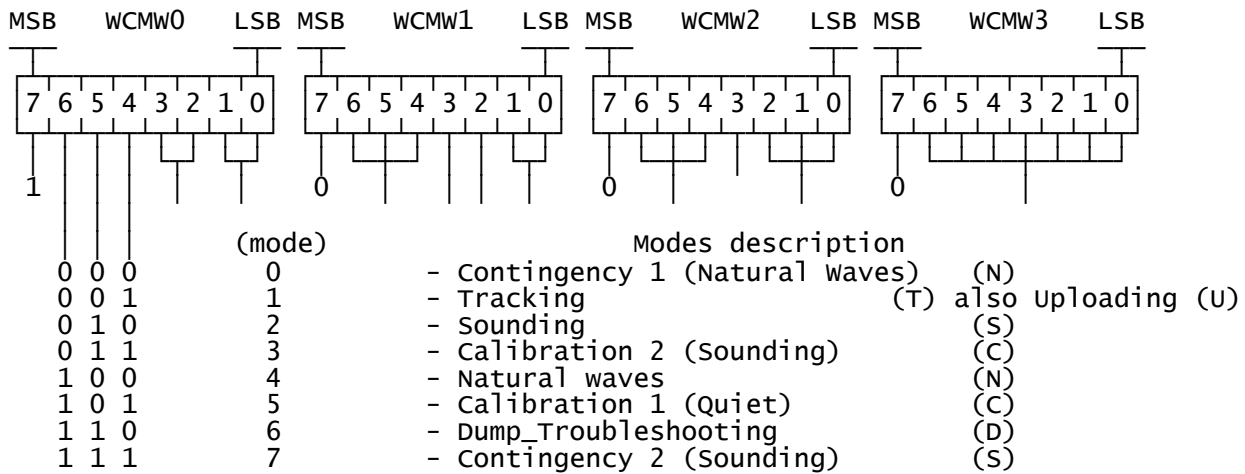

FFT size - Data block size (fft_size)

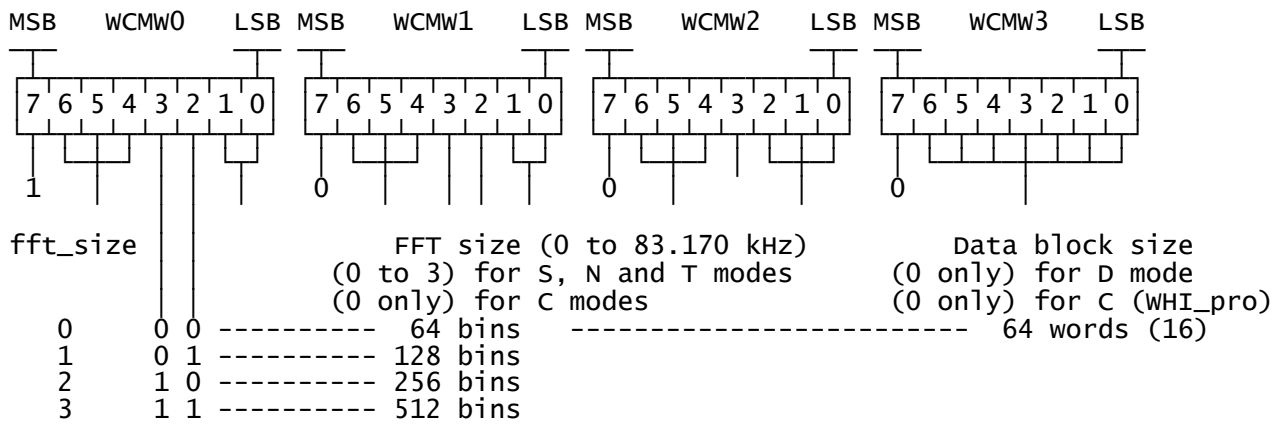

The FFT is applied to the range 0 to 83.170 kHz (fixed sampling frequency, 166.66kHz). Its size, M, defines the frequency resolution lower limit, 83.170/M in kHz. The final resolution may be larger, after processing inside DWP. In a S mode, M will generally be set to 512.

Repetition factor (rep_fac)

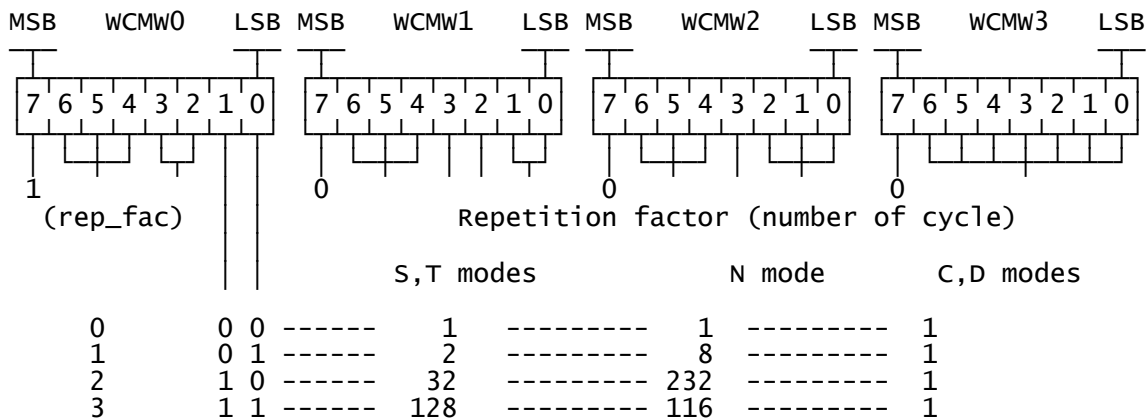

The repetition factor corresponds to the number of time the instrument works in the same configuration. It is one way to limit the sounder operations in case of a mistake or failure in the TC stream. It will also be of use in the definition of duty cycles.

Emis./Rec. Rate, Nb of averaged spectra (smode_aver)

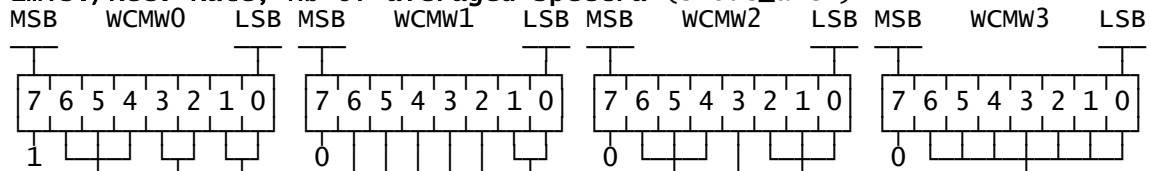

Emission/Reception Rate
S mode and T mode

Number of averaged spectra (N mode)
Duration :

(smode_aver) 0	1 E 1 R (13.33ms)	----- 0 0 0	---	32 spectra (426.66ms)
(smode_aver) 1	1 E 2 R (26.66ms)	----- 0 0 1	---	16 spectra (213.33ms)
(smode_aver) 2	1 E 3 R (40ms)	----- 0 1 0	---	16 spectra (213.33ms)
(smode_aver) 3	1 E 5 R (66.66ms)	----- 0 1 1	---	8 spectra (106.66ms)
(smode_aver) 4	1 E 8 R (106.66ms)	----- 1 0 0	---	4 spectra (53.33ms)
(smode_aver) 5 (T mode overwritten with smode_aver = 0)	Gliding mode	----- 1 0 1	---	2 spectra (26.66ms)
	2.125 Spin (8.5s)			
	40 x (1E 1R) (533.33ms)			
	+ A (waiting) (2106.66ms)			
	+ 256 x 1R (3413.33ms)			
	+ B (waiting) (2446.66ms adj.)			
	455 WHSS requested			
	296 frames issued			
(smode_aver) 6	SYNC A Spin/32 (125ms)	----- 1 1 0	---	64 spectra (853.33ms)
	(1E 5R) (80ms)			
	+ B (waiting) (45ms adj.)			
	6 WHSS requested			
	5 frames issued			
(smode_aver) 7	SYNC B Spin/16 (250ms)	----- 1 1 1	---	1 spectrum (13.33ms)
	(1E 13) (186.66ms)			
	+ B (waiting) (63.34ms adj.)			
	14 WHSS requested			
	13 frames issued			

SMODE 1E1R (S mode)

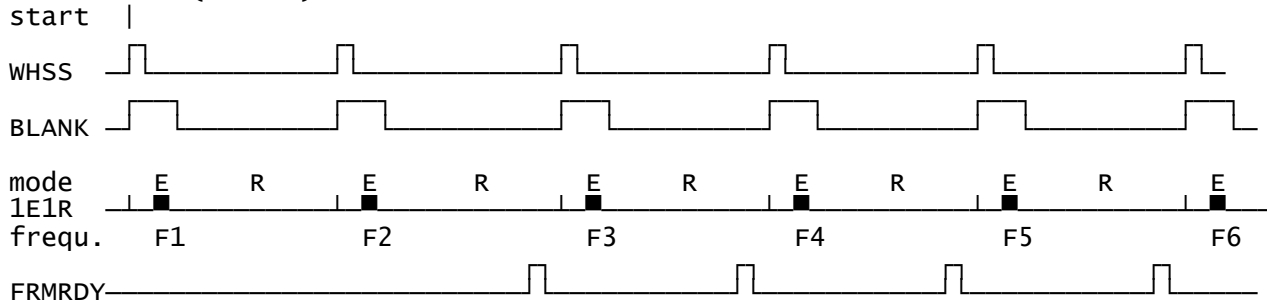

SMODE 1E3R

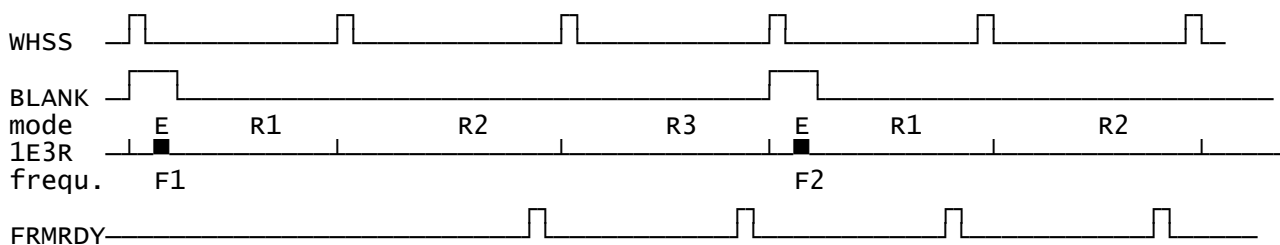

GLIDING MODE

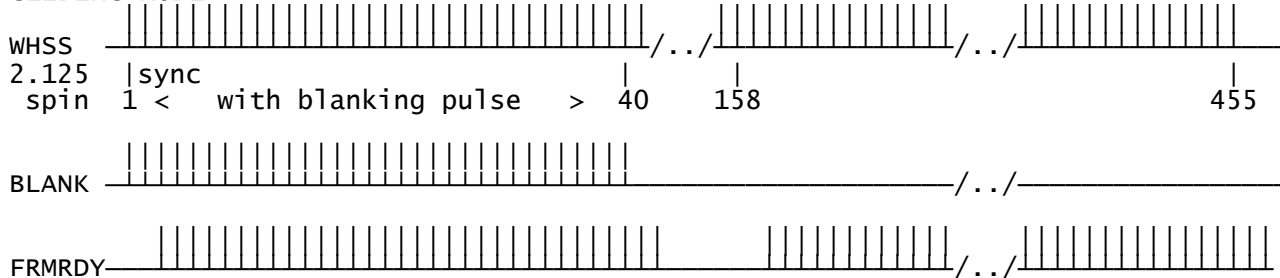

SYNC A MODE

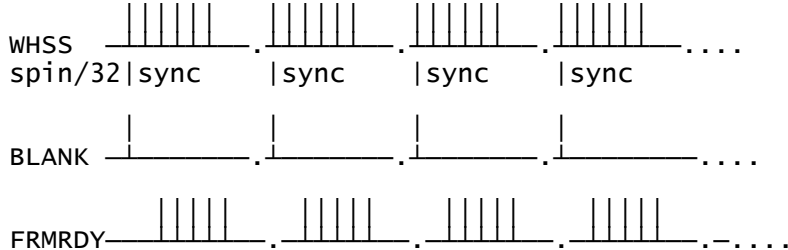

SYNC B MODE

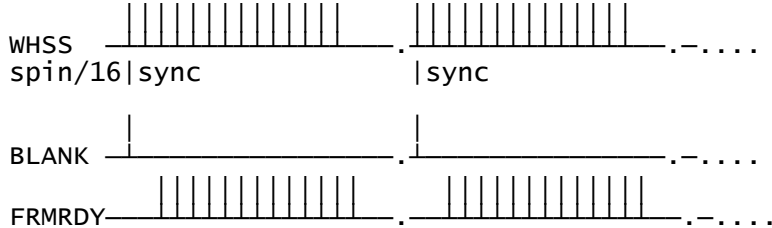

NOTE : a sounding sequence starts always with a BLANKING PULSE

WHISPER processing modes (whi_process)

If bit 3 of WCMW1 is set, a internal WHISPER processing is requested for tracking mode (mode 1), sounding mode (mode 2), natural waves mode (mode 4) and calibration modes (modes 3 & 5), allways used for troubleshotting mode (mode 6). In these modes DWP is requested to transmit the output data in a transparent mode, the WHISPER data flow is below 650 bit/sec exception is made for three dedicated modes internally processed, documented later in this paragraph.

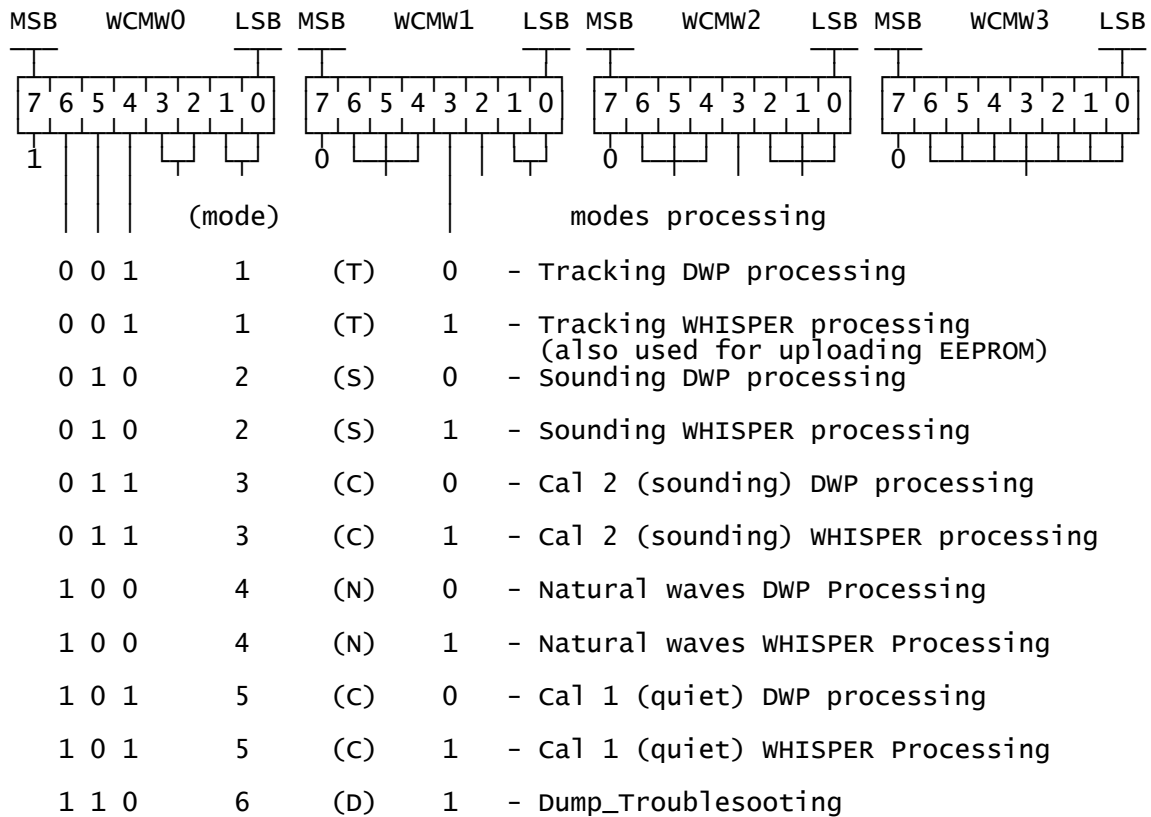

WHISPER internal processing dedicated modes

Three modes with WHISPER internal processing are implemented. These modes do not need any DWP application task and no WPW are set.

- Two modes are dedicated to natural waves mode they are :
 - a) 16 averages of fft 128 bins
 - b) 8 averages of fft 256 bins

NOTE : averages are true averages, energy and overflow values are also averaged.

- Two modes are dedicated to a sounding mode. For this mode DWP is requested to run WHISPER in continuous mode.

- a) Sounding 80 steps FST table 11
- b) Sounding 40 steps FST table 12 with listen delayed

The parameters : repetition factor, gain, overflow threshold and level (sounding) are addressable. All the other parameters are exclusive for these modes.

WHISPER Processed Natural Waves A (duration 74 ms + 1240 ms per cycle)

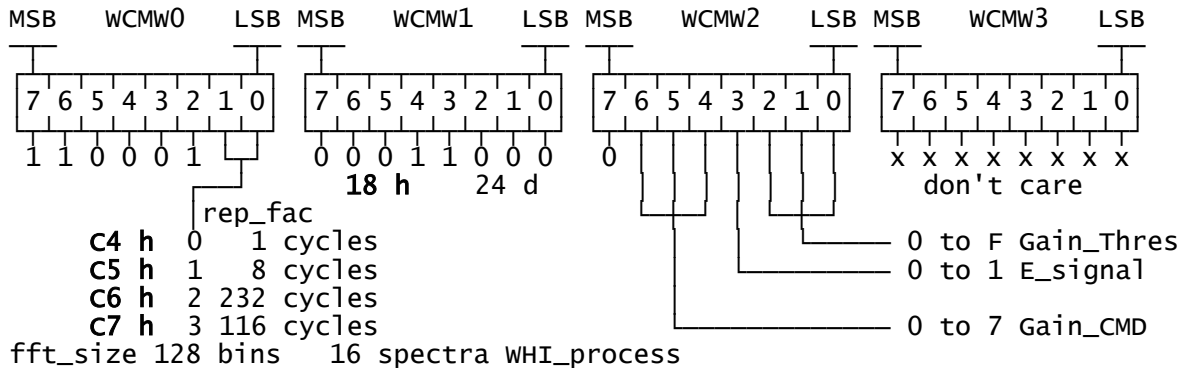

WHISPER Processed Natural Waves B (duration 74 ms + 1133.33 ms per cycle)

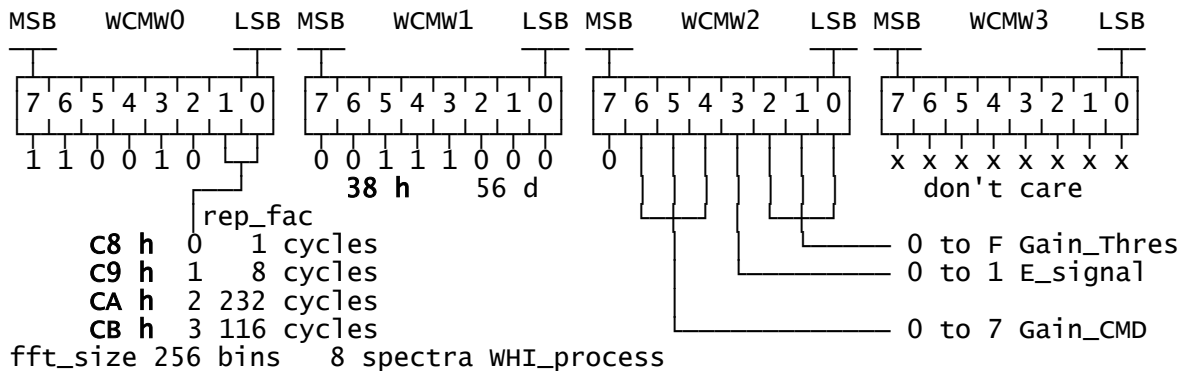

WHISPER Processed Sounding A (duration 74 ms + 4053 ms per cycle)

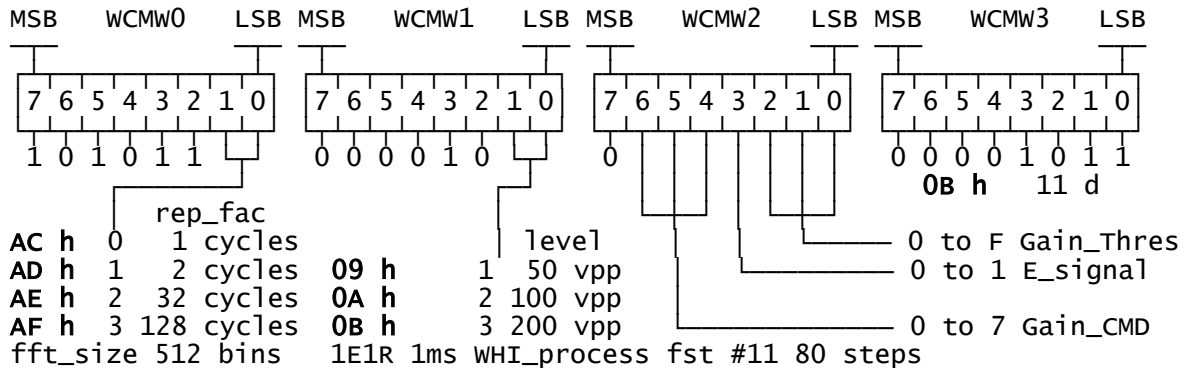

WHISPER Processed Sounding B listen delayed (duration 74 ms + 4053 ms per cycle)

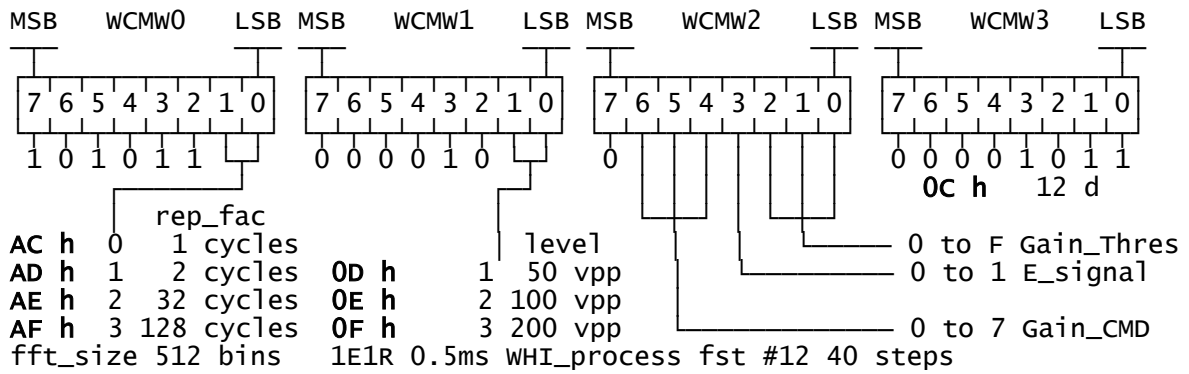

Pulse duration (PULSE)

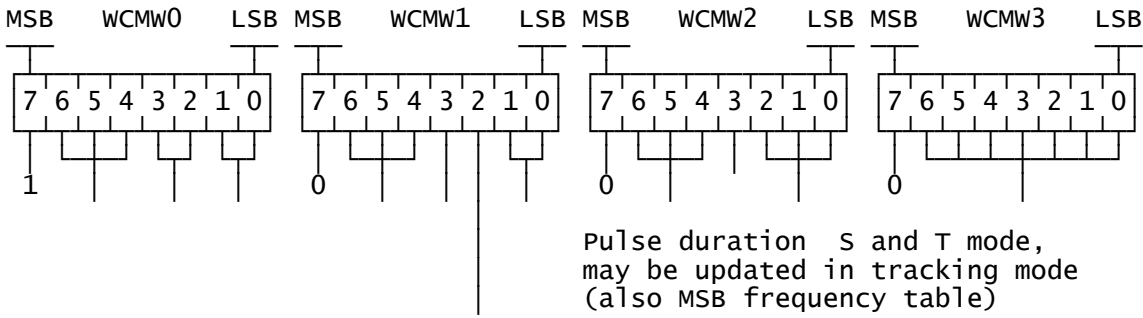

- 0 ----- Pulse 1.024ms
Also normal sampling for fixed tables
- 1 ----- Pulse 0.512ms
Also delayed sampling for fixed tables

In S modes, the frequency difference between two adjacent steps will be adjusted to the pulse duration : respectively 1 or 2kHz for 1 or 0.5ms. The related status bit (word 4 byte 1 bit 6) can be taken into account when interpreting the frequency scan mode bit.

NOTE : If the frequency table called by WCMW3 is a fixed table, the pulse duration is defined in the table for each frequency point and copied in the status words following transmission at that frequency. On the other hand, this PULSE command can be used sample the data with an extra delay of 13.33ms. This possibility is only valid for fixed frequency tables and all the smode 1E3R, 1E5R, 1E8R and Sync. (Smode_aver = 2, 3, 4, 6, 7).

The following example explains what are the two possible option in such case, here in smode 1E5R with fixed table, the output listen row will be :

- a) pulse = 0
All five receptions R1, R2, R3, R4, R5, after each transmission (see diagram p.8) are transfered to DWP they are stamped with listen_row values: 543215432154321...
- b) pulse = 1
The reception R1 is skipped, as the corresponding FrameReady signal, receptions R2, R3, R4, R5, are transfered to the DWP, stamped with Listen_row : 532153215321...

Emission (level)

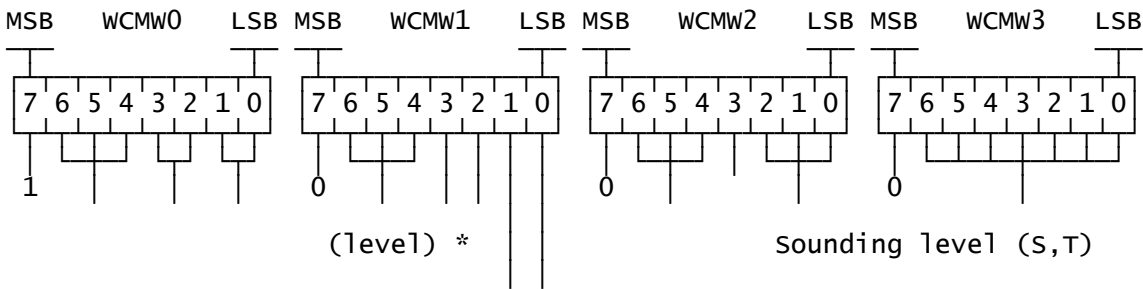

- 0 0 0 ----- No emission
- 1 0 1 ----- Sounding at 50 Vpp
- 2 1 0 ----- Sounding at 100 Vpp
- 3 1 1 ----- Sounding at 200 Vpp

* may be updated in tracking mode

Gain command (gain_cmd)

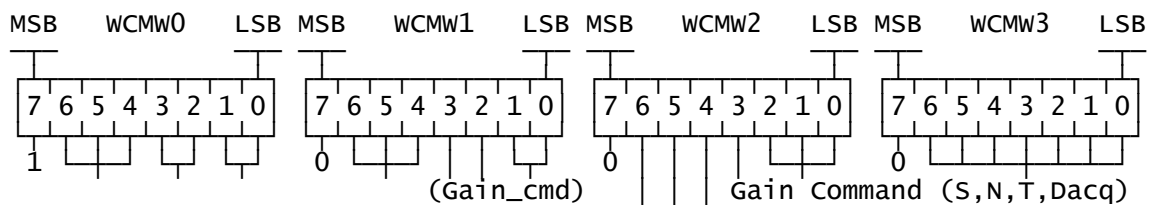

Gain Command	Gain
0	0 0 0 --- Fixed Gain + 12 dB
1	0 0 1 --- Fixed Gain + 24 dB
2	0 1 0 --- Fixed Gain + 36 dB
3	0 1 1 --- Fixed Gain + 36 dB
4	1 0 0 --- Auto Gain + 24 / + 12 dB
5	1 0 1 --- Auto Gain + 24 / + 12 dB
6	1 1 0 --- Auto Gain + 36 / + 24 dB
7	1 1 1 --- Auto Gain + 36 / + 24 dB

In acq_dump mode, bit 6 is ignored, thus only fixed gain is set.

Auto Gain Threshold/Dump acq-memory (gain_thres/dump_mem)

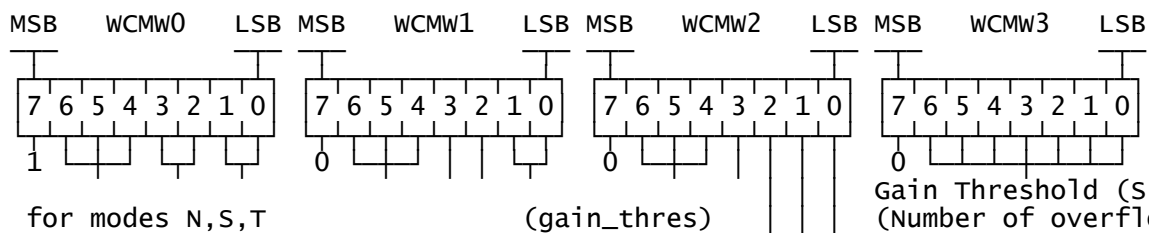

for modes N,S,T

(gain_thres)

Gain Threshold (S,N,T)
(Number of overflows during Gain control)

0	0 0 0	----- 0 (use of internal default value) (2 overflows for FM's)
1	0 0 1	----- from 3
7	1 1 1	----- to 15 (step 2)

for mode D (dump) (mode 6)

0	0 0 0	-- acquisition dump 1k (16) 18 frames of 64 words (16)
1	0 0 1	-- dump PROM μ C 2k (8) 18 frames of 64 words (16)
2	0 1 0	-- dump EEPROM μ C 32k (8) 283 frames of 64 words (16)
3	0 1 1	-- dump VSP PROM 8k (16) 142 frames of 64 words (16)
4	1 0 0	-- dump WINDOW RAM 1k (16) 18 frames of 64 words (16)
7	1 1 1	-- dump all prog. memories 461 frames of 64 words (16)

Receiver Connection (E_Signal)

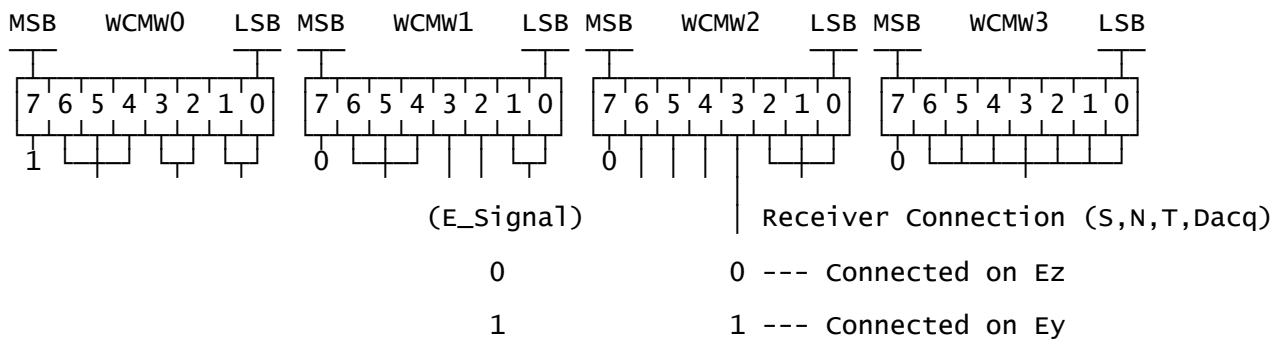

Frequency point, Frequency Range (fst)

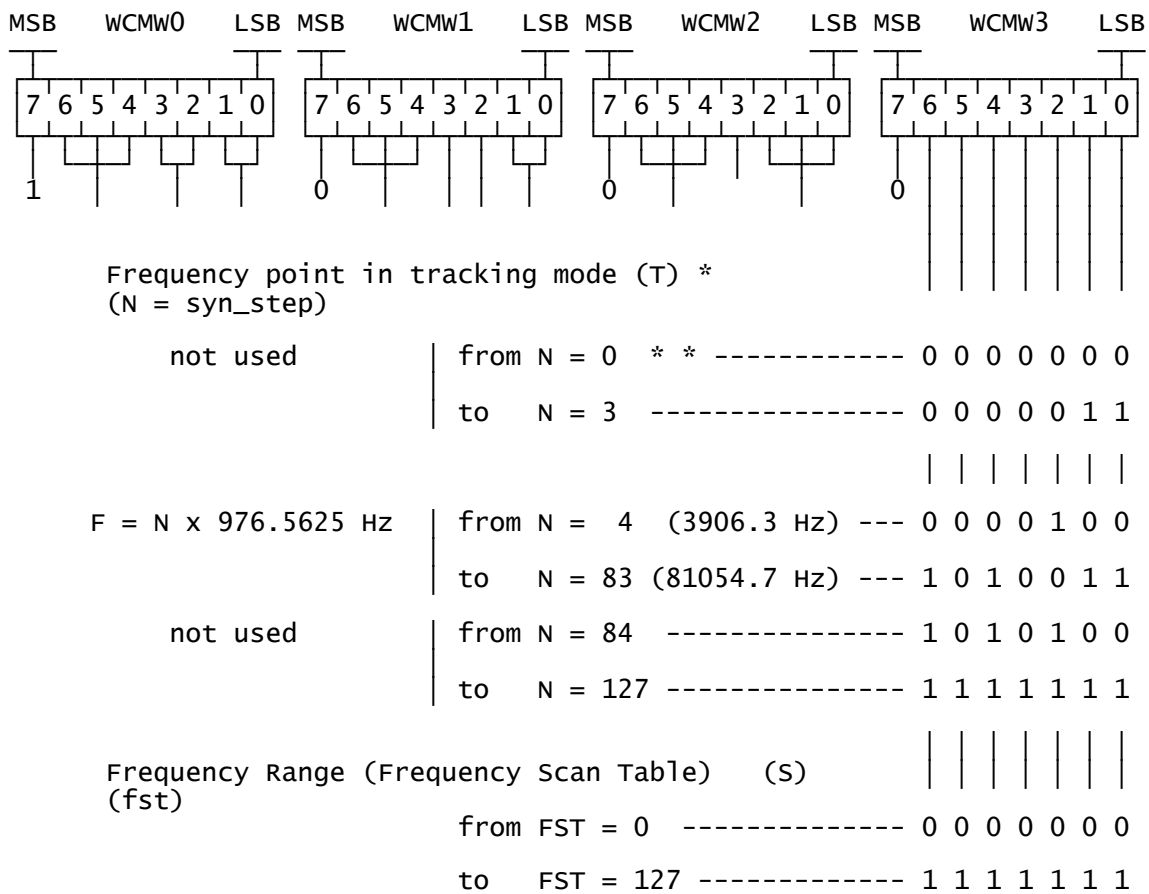

* may be updated in tracking mode.
 ** if set to 0, while in tracking mode, will stop the operation.

II-2 Data Post-Processing

DWP processing WHISPER Processing Word (WPW)

WHISPER Processing Word (WPW) - "Natural Waves" modes (N)

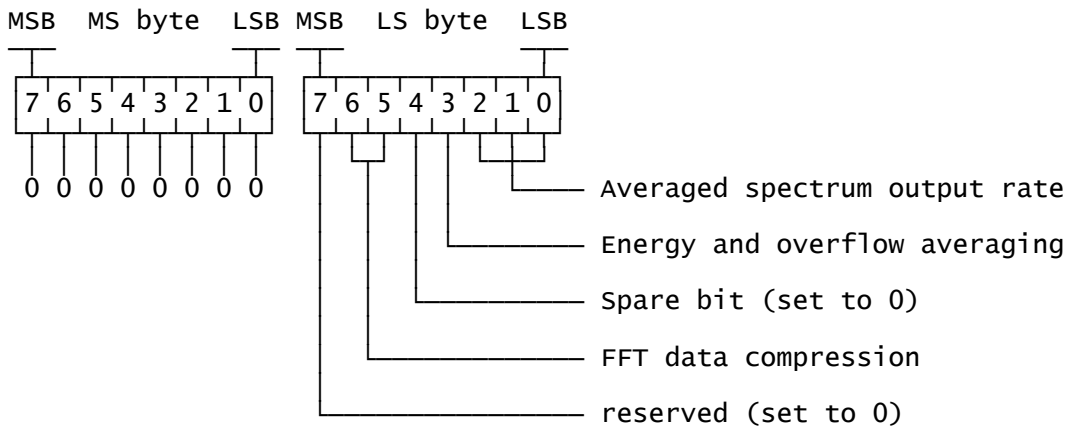

Averaged spectrum output rate

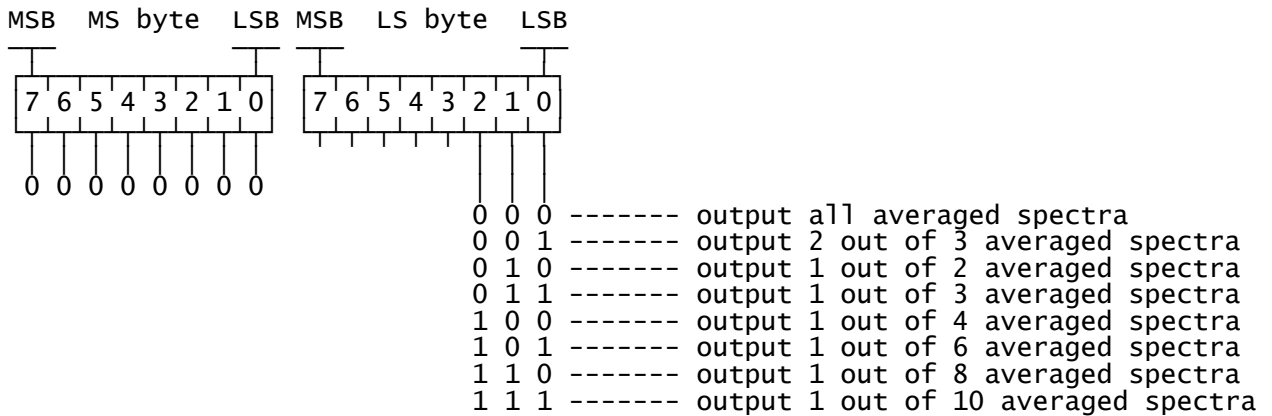

Energy and overflow averaging

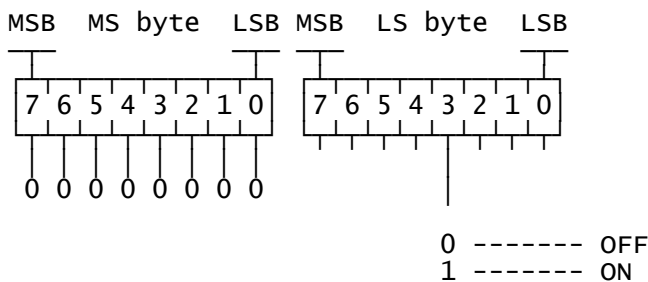

There is no option on Energy and overflow averaging in "sounding" modes. When this information is transmitted (gliding mode), the fixed option is : averaging ON.

FFT data compression

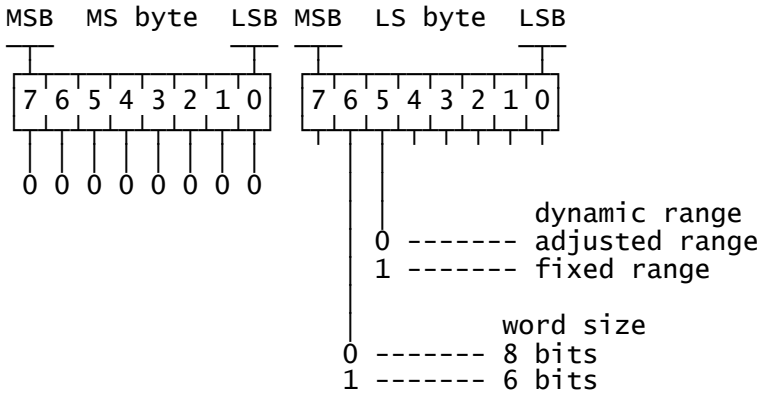

WHISPER Processing Word (WPW) - "Sounding" modes (S)

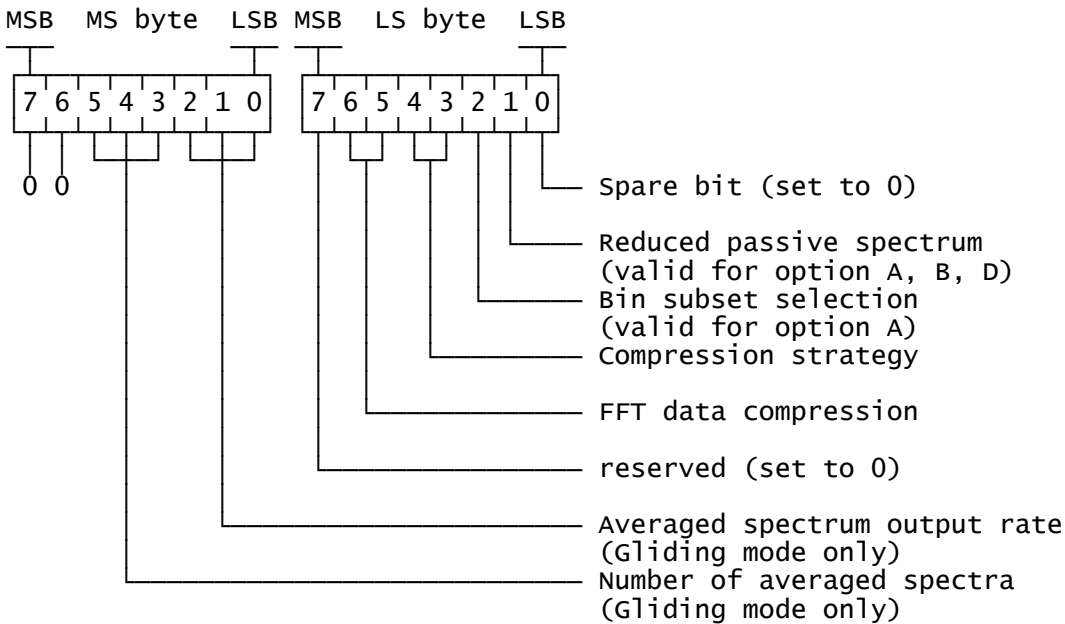

FFT data compression

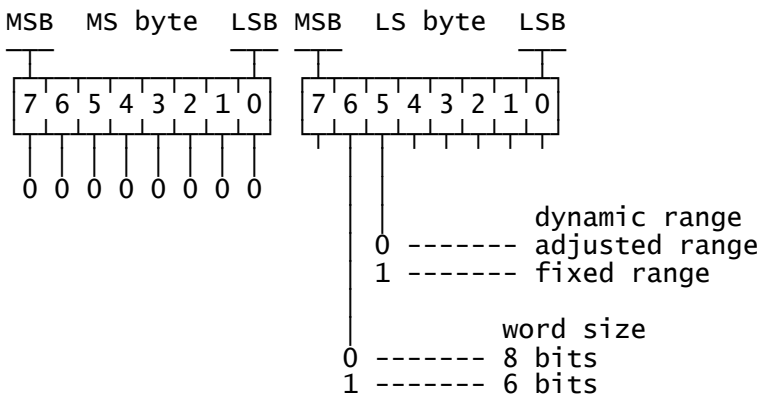

Reduced passive spectrum (valid for option A,B,D of the compression strategy)

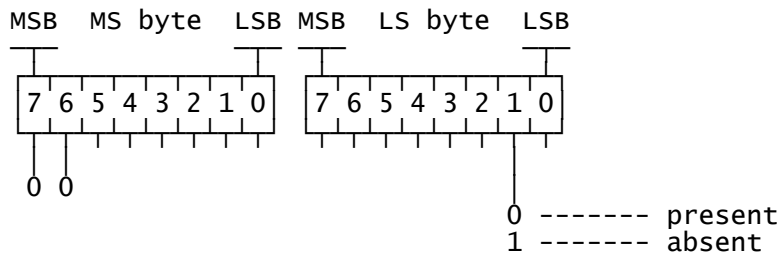

Bin subset selection (valid for option A of the compression strategy)

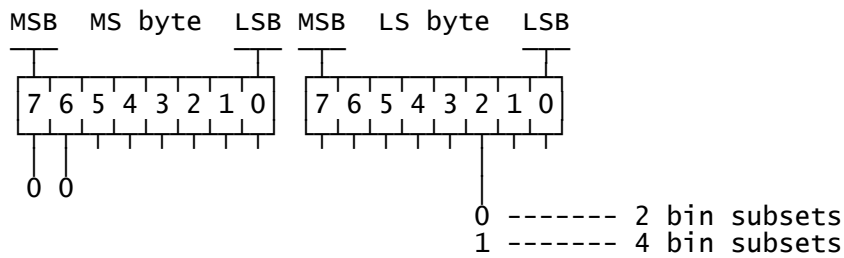

Compression strategy

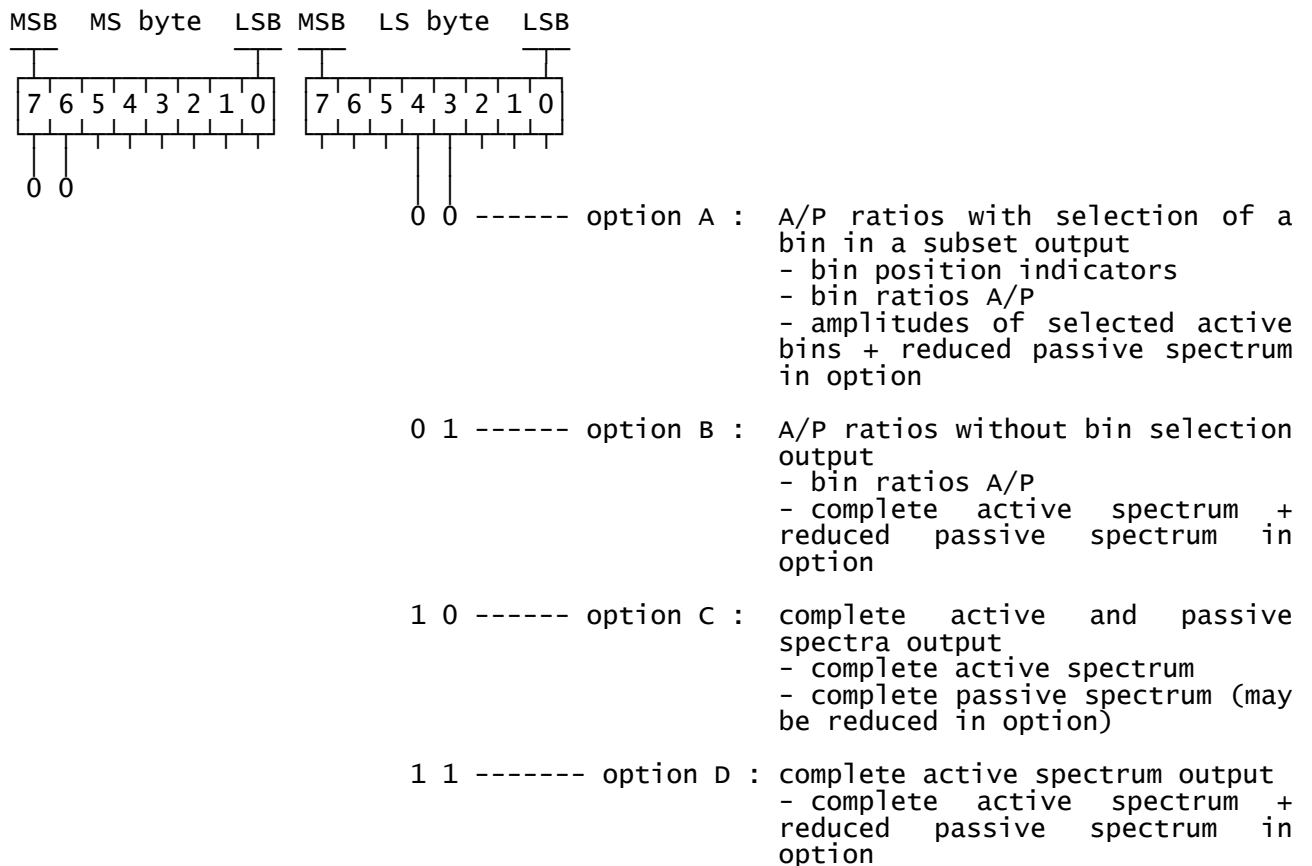

Averaged spectrum output rate

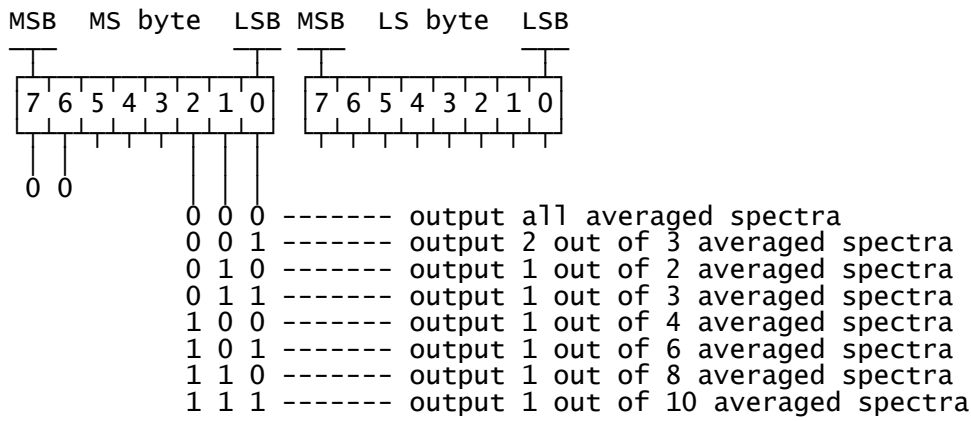

Number of averaged passive spectra

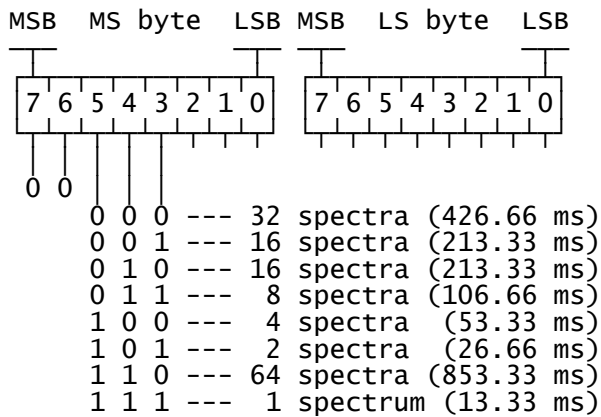

II-3 WHISPER default command (internal DWP)

the WPW 4F is to be used for this mode

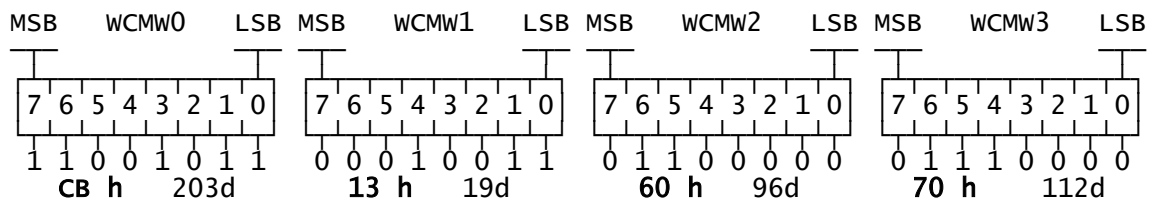

mode = 4 (natural waves)	smode_aver = 1 (16 spectra)	gain_cmd = 6 (+36/+24 dB)	fst = 112 (default for active)
fft_size = 2 (256 bins)	whi_pro = 0 (DWP processing)	gain_thres = 0 (2 overflows)	
rep_fac = 3 (116 cycles)	PULSE = 0 (1.024)	E_signal = 0 (Ez)	
	level = 3 (200 Vpp default for active)		

II-4 Contingency modes

Rules

After receiving a command from the DWP the integrity of the WCMW is checked according to the rules defined below.

- for the normal operations,
 - if a WCMW anomaly is detected
 - or the mode decoded in WCMW0 is contingency 1 (natural)
 - : a contingency mode 1 (Natural waves) is issued.
 - if the mode decoded in WCMW0 is contingency 2
 - : a contingency mode 2 (Sounding) is issued.

List of criteria for anomaly :

- the MSB (bit) of the WCMW words must be respectively 1, 0, 0, 0

Contingency mode 1 (Natural waves)

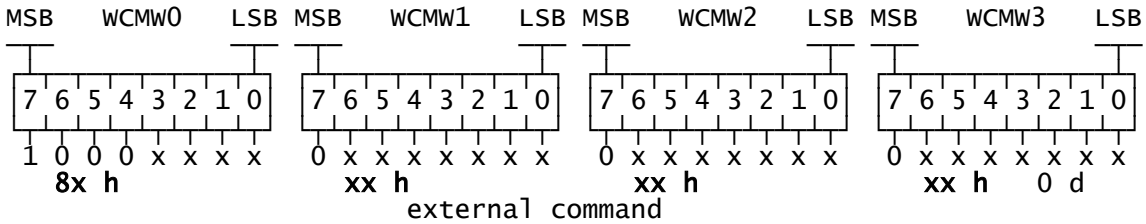

1 0 0 0 0 0 0 0	1 1 1 1 0 0 0 0	0 1 1 0 0 0 0 0	0 0 0 0 0 0 0 0
80h 128 d	78 h 120d	60 h 96 d	00 h 0 d
WHISPER internal default values set by an abnormal commanding or the above command			

mode = 0 (contingency 1)	smode_aver = 7 (1 spectrum)	gain_cmd = 6 (+36/+24 dB)	fst = 0
fft_size = 0 (64 bins)	whi_pro = 1 (WHI processing)	gain_thres = 0 (2 overflows)	
rep_fac = 0 (1 cycles)	PULSE = 0 level = 0	E_signal = 0 (Ez)	

Contingency mode 2 (Sounding)

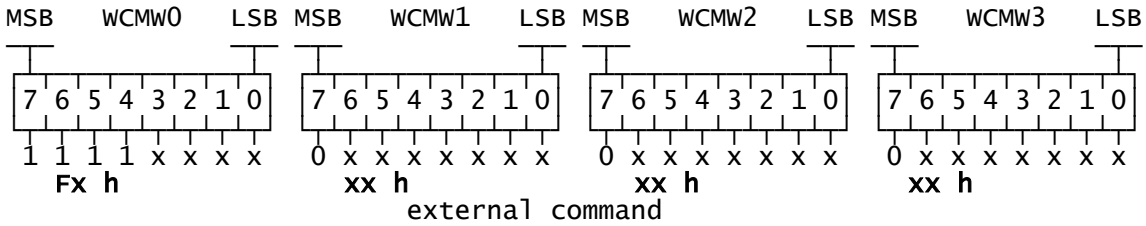

1 1 1 1 1 1 0 0	0 0 0 0 1 0 1 0	0 1 1 0 0 0 0 0	0 1 1 1 0 0 0 0
FC h 252 d	0A h 10 d	60 h 96 d	70 h 112 d
internal default values set by an abnormal commanding			

mode = 7 (contingency 2)	smode_aver = 0 (1E 1R)	gain_cmd = 6 (+36/+24 dB)	fst = 112 (83 to 4, 80 steps)
fft_size = 3 (512 bins)	whi_pro = 1 (WHI processing)	gain_thres = 0 (2 overflows)	
rep_fac = 0 (1 cycles)	PULSE = 0 (1.024 ms)	E_signal = 0 (Ez)	
	level = 2 (100 Vpp)		

II-5 Uploading and protect/unprotect S/W (ground operation)

These WCMW commands will be used, **only during ground operation**, to allow the updating of the micro-controller programme stored in EEPROM.

The presence of the 27v is of no importance for this mode.

These special modes issue an output data frame of 64 words at the end of the loading programme, including the checksum of the EEPROM for verification. Only the status words are significant, other are meaningless.

NOTE : For the three following commands, the WHISPER EEPROM LOADER must be connected to the J05 (HV Ctrl/Test) connector in order to enable the hardware WR (write) of the EEPROM. The WHISPER EEPROM LOADER includes HV disabling.

[load] uploads a new software into EEPROM

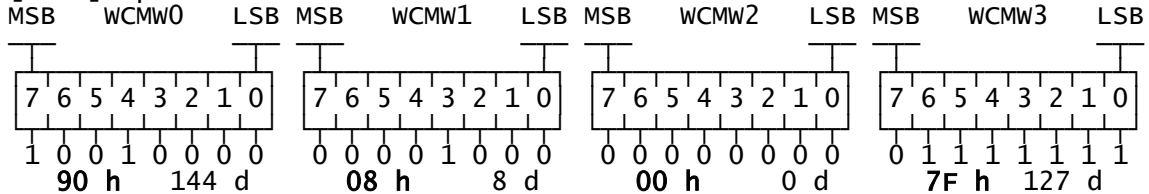

[protect] activates the SWP (Software Write Protect) of the EEPROM

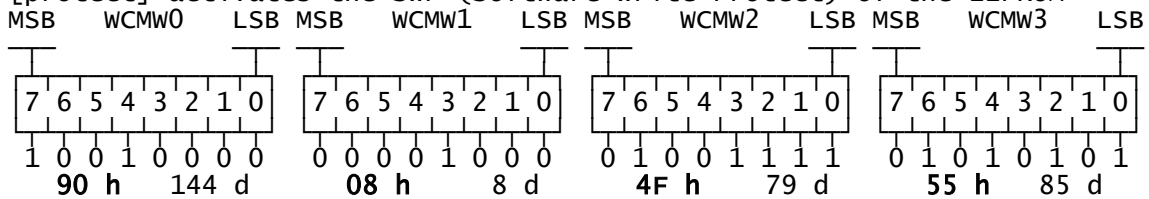

[unprotect] deactivates the SWP of the EEPROM

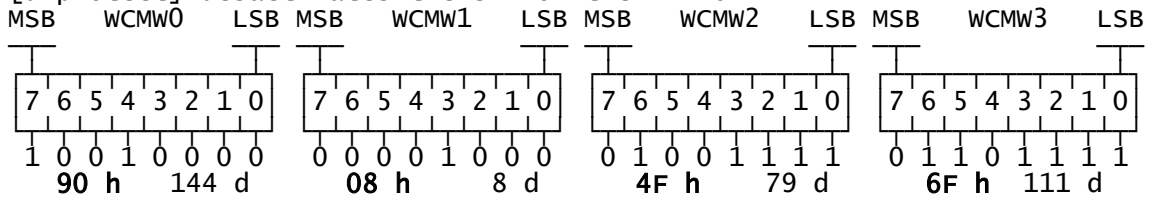

Basic procedure for uploading a new EEPROM programme.

Commands and data collection can be performed via CCS, WEC EGSE or WHISPER GSE (MINI-DPU) according to the present setup.

- connect the EEPROM LOADER and the associated NOTEBOOK
- POWER ON WHISPER (and DWP or MINI-DPU)
- issue the unprotect command, record the present checksum
- issue the load command
- run the uploading programme on the NOTEBOOK
- when completed, record the new checksum
- issue the protect command, record the modification of the new checksum and verify the protect status
- POWER OFF WHISPER (and DWP or MINI-DPU)
- disconnect the EEPROM LOADER and the associated NOTEBOOK
- uploading operation completed

NOTE : A protect status (value 0x55) will overwrite the last byte of the EEPROM (at address 0xFFFF) when the protect command is issued. The EEPROM checksum is affected with the value of this status. The protect status is cleared when the unprotect command is issued and the initial checksum is restored.

II-6 Calibration modes

These WCMW commands will be used to allow the verification of the receiver transfer function and the transmitter transfer function.

The calibration 1 (quiet) is a passive calibration ; the syntheziser is connected internally and as the transmitter is not operating, the 27 V is off.

The calibration 2 (sounding) is an active calibration ; the transmitter output is connected to the receiver input, via an attenuator, and the 27 V power is needed for this calibration (27 V on). As the transmitter is still connected to the antennae braids, this calibration is "active" and a blanking pulse will be issued according to the transmitted pulse (1.024ms). During both calibrations, the levels are checked for several frequency points in all receiver gain levels. The parameters for both calibrations (steps, frequencies, levels, gains) are internally programmed and thus, they cannot be modified in flight by commanding.

The calibration 2 is selected internally, only if the 27 V is on and the calibration 1 is selected if the 27 V is off. The two different commands are issued only to advise the DWP to switch on or off the 27 V according to the requested mode.

In all calibration modes, when the frequency step is 0, the receiver input is reconnected to the EFW antennae, giving the background noise level.

Calibration 1 mode (Quiet) 99 steps (duration 160 secondes).

frequency steps : 124, 100, 76, 72, 64, 52, 36, 20, 16, 8, 0
 hexa : 7C, 64, 4C, 48, 40, 34, 24, 18, 10, 8, 0

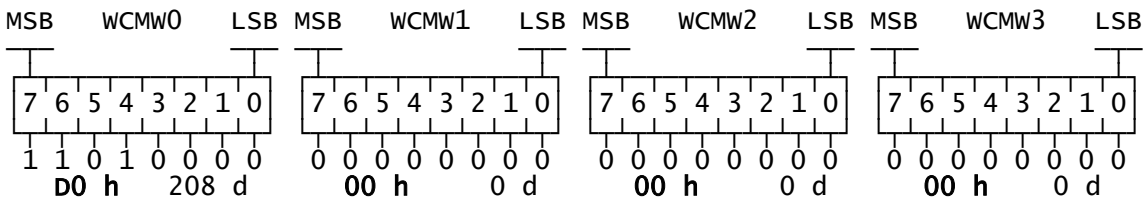

calibration 2 mode (Sounding) 99 steps (duration 160 secondes).

blanking pules are issued by DWP at a rate of 13.33 ms

frequency steps : 76, 72, 64, 52, 44, 36, 20, 16, 12, 8, 0
 hexa : 4C, 48, 40, 34, 2A, 24, 18, 10, 0C, 08, 00

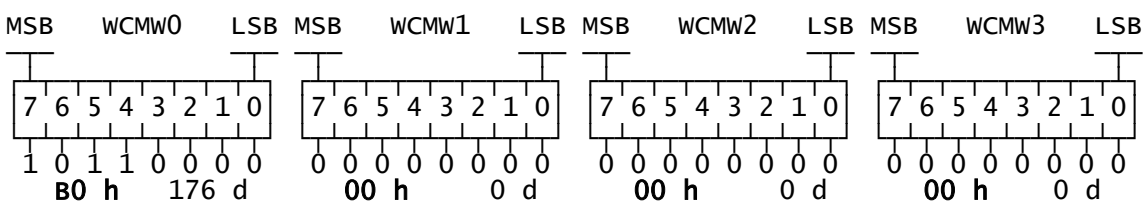

NOTE :

- These two calibration modes will issue 99 frames of 64 bins (moduli) at a rate of one frame every 1.6 second (120 x 13.3 ms).

calibration 1 whi_pro (Quiet) 45 steps (duration 690 ms).
 frequency steps : 124, 100, 76, 72, 64, 52, 36, 20, 16, 8, 0
 hexa : 7C, 64, 4C, 48, 40, 34, 24, 18, 10, 8, 0

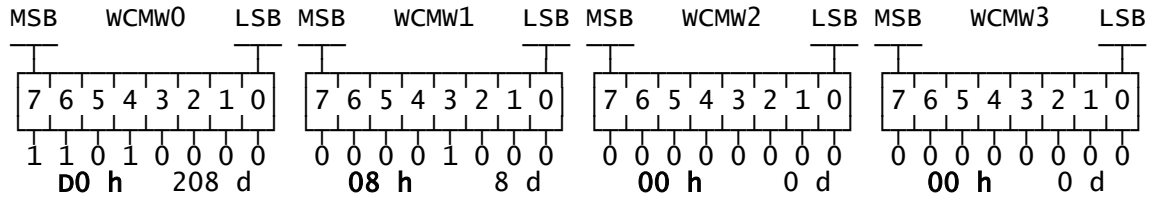

calibration 2 whi_pro (Sounding) 45 steps (duration 690 ms).
 frequency steps : 76, 72, 64, 52, 44, 36, 20, 16, 12, 8, 0
 hexa : 4C, 48, 40, 34, 2A, 24, 18, 10, 0C, 08, 00

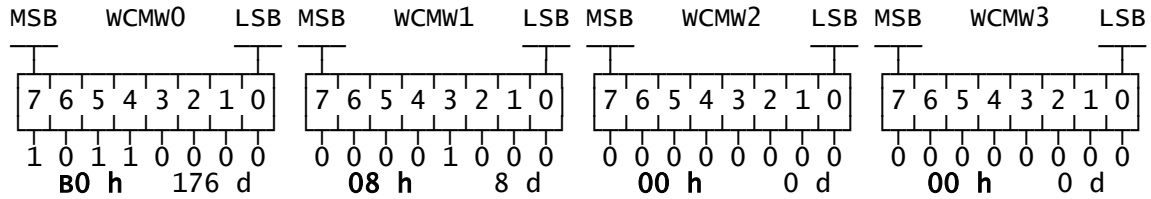

NOTE :
 - These two calibration modes will issue one frame of 64 words at the end of the WHISPER internal processing.
 - These two calibration modes are part of the WHISPER automatic test.

Sequence for QUIET CALIBRATION

STEP	FREQUENCY	LEVEL	GAIN
0	7C h 124 d	1	0 NOT TESTED */
1	64 h 100 d	1	0 NOT TESTED */
2	4C h 76 d	1	0 */
3	48 h 72 d	1	0 */
4	40 h 64 d	1	0 */
5	34 h 52 d	1	0 */
6	24 h 36 d	1	0 */
7	14 h 20 d	1	0 */
8	10 h 16 d	1	0 */
9	08 h 8 d	1	0 */
10	00 h 0 d	1	0 ENERGY */
11	4C h 76 d	1	1 */
12	10 h 16 d	1	1 */
13	4C h 76 d	1	2 */
14	10 h 16 d	1	2 */
15	7C h 124 d	2	0 NOT TESTED */
16	64 h 100 d	2	0 NOT TESTED */
17	4C h 76 d	2	0 */
18	48 h 72 d	2	0 */
19	40 h 64 d	2	0 */
20	34 h 52 d	2	0 */
21	24 h 36 d	2	0 */
22	14 h 20 d	2	0 */
23	10 h 16 d	2	0 */
24	08 h 8 d	2	0 */
25	00 h 0 d	2	0 ENERGY */
26	4C h 76 d	2	1 */
27	10 h 16 d	2	1 */
28	4C h 76 d	2	2 */
29	10 h 16 d	2	2 */
30	7C h 124 d	3	0 NOT TESTED */
31	64 h 100 d	3	0 NOT TESTED */
32	4C h 76 d	3	0 */
33	48 h 72 d	3	0 */
34	40 h 64 d	3	0 */
35	34 h 52 d	3	0 */
36	24 h 36 d	3	0 */
37	14 h 20 d	3	0 */

38	10	h	16	d	3	0	*/
39	08	h	8	d	3	0	*/
40	00	h	0	d	3	0	ENERGY */
41	4C	h	76	d	3	1	*/
42	10	h	16	d	3	1	*/
43	4C	h	76	d	3	2	*/
44	10	h	16	d	3	2	*/

Sequence for SOUNDING CALIBRATION

STEP	FREQUENCY			LEVEL	GAIN		
0	4C	h	76	d	1	0	*/
1	48	h	72	d	1	0	*/
2	40	h	64	d	1	0	*/
3	34	h	52	d	1	0	*/
4	2C	h	44	d	1	0	*/
5	24	h	36	d	1	0	*/
6	18	h	24	d	1	0	*/
7	10	h	16	d	1	0	*/
8	0C	h	12	d	1	0	*/
9	08	h	8	d	1	0	*/
10	00	h	0	d	1	0	ENERGY */
11	4C	h	76	d	1	1	*/
12	10	h	16	d	1	1	*/
13	4C	h	76	d	1	2	*/
14	10	h	16	d	1	2	*/
15	4C	h	76	d	2	0	*/
16	48	h	72	d	2	0	*/
17	40	h	64	d	2	0	*/
18	34	h	52	d	2	0	*/
19	2C	h	44	d	2	0	*/
20	24	h	36	d	2	0	*/
21	18	h	24	d	2	0	*/
22	10	h	16	d	2	0	*/
23	0C	h	12	d	2	0	*/
24	08	h	8	d	2	0	*/
25	00	h	0	d	2	0	ENERGY */
26	4C	h	76	d	2	1	*/
27	10	h	16	d	2	1	*/
28	4C	h	76	d	2	2	*/
29	10	h	16	d	2	2	*/
30	4C	h	76	d	3	0	*/
31	48	h	72	d	3	0	*/
32	40	h	64	d	3	0	*/
33	34	h	52	d	3	0	*/
34	2C	h	44	d	3	0	*/
35	24	h	36	d	3	0	*/
36	18	h	24	d	3	0	*/
37	10	h	16	d	3	0	*/
38	0C	h	12	d	3	0	*/
39	08	h	8	d	3	0	*/
40	00	h	0	d	3	0	ENERGY */
41	4C	h	76	d	3	1	*/
42	10	h	16	d	3	1	*/
43	4C	h	76	d	3	2	*/
44	10	h	16	d	3	2	*/

II-7 Troubleshooting modes

In all the troubleshooting modes the sequence produces a number of frames of 64 words at a rate of (120 x 13.33 ms) 1.6 seconde.

Acquisition Dump mode

An Acquisition dump mode can also be invoked by commanding the troubleshooting mode commande with (dump_mem) set to 0. with this command a 1 k word (16 bit) of the EFW signal is sampled and dumped. The output are 18 frames starting with a block of 6 status words followed by 58 data words.

The gain can be commanded by using the WCMW2 (bit 4, 5, 6 ,7). Fix gain only.

Programme Memories Dump modes

Several programme memories dump modes can be invoked by commanding the troubleshooting mode commande including a four bit word (dump_mem) in WCMW2 bit 0 to 3. with this command a programmes memory dump is performed separatly or together according to the four bit word. The output data frame contains block of 6 status words followed by 58 data words.

MSB	WCMW0	LSB	MSB	WCMW1	LSB	MSB	WCMW2	LSB	MSB	WCMW3	LSB						
7 6 5 4 3 2 1 0	1 1 1 0 0 0 0 0	E0 h	224 d	7 6 5 4 3 2 1 0	0 0 0 0 1 0 0 0	08 h	8 d	7 6 5 4 3 2 1 0	x x x x x x x x	7 6 5 4 3 2 1 0	0 0 0 0 0 0 0 0	00 h	0 d				
Receiver on Ez	gain	12 dB	00 h	0 0 0 0 0 0 0 0	-- acquisition dump 1k (16)	24 dB	10 h	0 0 0 1 0 0 0 0	18 frames of 64 words (16)	36 dB	20 h	0 0 1 0 0 0 0 0		36 dB	30 h	0 0 1 1 0 0 0 0	
Reciever on Ey	gain	12 dB	08 h	0 0 0 0 0 1 0 0	-- acquisition dump 1k (16)	24 dB	18 h	0 0 0 1 1 0 0 0	18 frames of 64 words (16)	36 dB	28 h	0 0 1 0 1 0 0 0		36 dB	38 h	0 0 1 1 1 0 0 0	
			01 h	0 0 0 0 0 0 0 1	-- dump PROM μC 2k (8)				18 frames of 64 words (16)								
			02 h	0 0 0 0 0 0 1 0	-- dump EEPROM μC 32k (8)				283 frames of 64 words (16)								
			03 h	0 0 0 0 0 0 1 1	-- dump VSP PROM 8k (16)				142 frames of 64 words (16)								
			04 h	0 0 0 0 0 1 0 0	-- dump WINDOW RAM 1k (16)				18 frames of 64 words (16)								
			07 h	0 0 0 0 0 1 1 1	--dump all program memories				461 frames of 64 words (16)								

WHISPER Do Nothing mode

with the command :

0xE008x0nn (0 < nn < 7F)

WHISPER will do nothing and stay in a standby mode, awaiting for a command, no data frame are issued.

WHISPER ALARME mode

with the command :

0xE008x07F

an alarme is sent to the DWP about 12 secondes after issuing this command. This is to check the WHISPER power OFF generated by DWP when an alarme is issued.

II-8 File naming & examples of some valid commands

WHISPER Test file naming

names for calibration modes :

whi process CALQWHI.nnu = cal quiet CALSWHI.nnu cal sounding
dwp process CALQDWP.nnu = cal quiet CALSDWP.nnu cal sounding

name for uploading/protect YYMMDDHH.nnu (DayMonthYearHour)

WHISPER operation file names = m1FXGySz.nnu

m = mode designation

= N for Natural waves modes (4)
= S for Sounding modes (2)
= T for Tracking modes (1)
= D for Dump Acq modes (6)

l = level of the transmitter

= 0 for Natural waves modes

	Sounding	or	Tracking		Memory Dump
= 0	DumpAcq				

= 1	50 vpp 1.024 ms	= A	50 vpp 0.512 ms	= 1	Dump Prom MC
-----	-----------------	-----	-----------------	-----	--------------

= 2	100 vpp 1.024 ms	= B	100 vpp 0.512 ms	= 2	Dump Eeprom
-----	------------------	-----	------------------	-----	-------------

= 3	200 vpp 1.024 ms	= C	200 vpp 0.512 ms	= 4	Dump Prom VSP
-----	------------------	-----	------------------	-----	---------------

(F) x = frequency of the stimuli for N, S & D, of the transmit. in T modes
= 0 no stimuli

= 1	for 11,72 kHz	= 1	step 12 (0C h)	(11.72 kHz)
-----	---------------	-----	----------------	-------------

= 2	for 43 kHz	= 2	step 44 (2B h)	(43 kHz)
-----	------------	-----	----------------	----------

= 3	for 70,3 kHz	= 3	step 72 (48 h)	(70.3 kHz)
-----	--------------	-----	----------------	------------

(G) y = Gain of the receiver (and stimuli level)

= 0 + 12 dB (500 mVpp)

= 1 + 24 dB (125 mVpp)

= 2 + 36 dB (31.2 mVpp)

= 5 auto + 24/12 dB (~ 450 mVpp)

= 6 auto + 36/24 dB (~ 110 mVpp)

(S) z = Size of the output data or FFT

= 1 for 64 words or 64 bins

= 2 for 128 words or 128 bins

= 3 for 256 words or 256 bins

= 4 for 512 words or 512 bins

nn = row number 00 to 99 or AA to ZZ

(Rn reserved for reference files)

(An reserved for ATERMES acceptance)

(Ln reserved for LPCE tests)

(Tn reserved for thermal test)

u = unit identifier

= 5 for F5

= 6 for F6

= 7 for F7

= 8 for F8

= S for FS

= E for EM

= M for MST

Examples of some valid commands

Uploading

0x90804F6F (unprotect) 0x9008007F (load) 0x90084F55 (protect)

Calibration

0xB0080000 (passive) 0xB0080000 (active) [WHI process]
0xD0000000 (passive) 0xD0000000 (active) [DWP process]

Dump

0xE0080000 (acquisition gain 12 dB)
0xE0080100 (PROM MC)
0xE0080200 (EEPROM MC)
0xE0080300 (PROM VSP)
0xE0080400 (RAM WIN)

Natural

0xC1780000 fft 64 bins gain 12 dB 8 cycles WHI average 1
0xC5781000 fft 128 bins gain 24 dB 8 cycles WHI average 1
0xC9782000 fft 256 bins gain 36 dB 8 cycles WHI average 1
0xCD786000 fft 512 bins gain 36/24 dB 8 cycles WHI average 1

Sounding

0xAC29600B 1E3R 1ms 50v fft 512 b. 36/24 dB 1 cycle WHI 80-4 kHz
0xAC2A600B 1E3R 1ms 100v fft 512 b. 36/24 dB 1 cycle WHI 80-4 kHz
0xAC2B600B 1E3R 1ms 200v fft 512 b. 36/24 dB 1 cycle WHI 80-4 kHz
0xAC2F600A 1E1R 0.5ms 200v fft 512 bins gain 36/24 dB 1 cycle WHI short

III OUTPUT DATA FORMAT

III-1 General

Basically, WHISPER output data are the result of a FFT computation. Data are stored in a dual port memory and are read by the DWP every basic sequence of 13.33 mS in sounding and tracking modes, and at the end of each averaged natural wave mode.

The length of the data to be read is related to the FFT size set in the WCMW0 (bit 2 and 3).:

FFT size output bins	nb of memory words to be read by the DWP
64	64
128	128
256	256
512	512

Each data bin is a modulus number coded as a 16-bit word. Output data are stored in the natural bin order.

The first eight output 16 bit words, corresponding to the data of the first bins, which are meaningless, are overwritten by several status words related to the pending operation. These status word are updated at the rate of the WHISPER basic sequence ($40/3 = 13.33\text{ms}$)

The first four words are the WHISPER Actual Mode Words (WAMW). They describe the operating mode actually running.

The following words receive a copy of the WHISPER Command Mode word (WCMW).

The last two words are (see Chap.II para 8) and contain the integrated value of the first 128 sampled data.

NOTE : These 8 words will be available in the output data frame and will be updated after each WHISPER basic sequence.

In the D mode a number of 64 words frames start with 6 status words including the "w" identifier, and then continue with 58 words of data. The pattern of these status words are described later.

III-2 Housekeeping Data

The WHISPER housekeeping data are built by the DWP by copying the 8 status words quoted above.

In addition this 8 (16bit) words housekeeping will allow the WHISPER EGSE to control the operation during all the AFT (Abbreviated Functional Tests), and to demonstrate the integrity of WHISPER.

The WHISPER HK data are located in the WEC HK frame in a shared area. The content of this area of HK is dependent on the current WEC mode.

In all WEC modes, except for the WBD Burst Data mode, these words hold the WHISPER HK.

In the WDB Burst mode, when the WHISPER instrument must be powered off, this words hold the WDB Gain state information.

The WHISPER/WBD HK area has a most significant byte identifier. A value of 0 means that the next 8 words contain WHISPER HK.

In addition the "W" identifier placed in the WHISPER data frame is overwritten by the DWP with a WH interface status word (format TBD).

WHISPER HK vs WEC HK

WHISPER STATUS DATA		WEC HK		
			WHISPER HK	WBD HK
		word 0	0	1
word 0	"w"-step_row	word 1	WH interface status	WBD HK
word 1	VSP scale	word 2	VSP scale	"
word 2	ovf/gain/mode	word 3	ovf/gain/mode	"
word 3	wd/row/rec	word 4	wd/row/rec	"
word 4	WCMW0/WCMW1	word 5	WCMW0/WCMW1	"
word 5	WCMW2/syn_step	word 6	WCMW2/syn_step	"
word 6	LSW energy	word 7	LSW energy	"
word 7	MSW energy	word 8	MSW energy	"

III-3 WHISPER Actual Mode Words (WAMW) Status

Each whisper output data frame starts with the WAMW 8 words (16 bit) for the normal operation.

Identifier step_row

The byte 1 always contains an identifier for WHISPER corresponding to the ASCII values of the letter "w".

The byte 0 is set with the decremented number of the step within a sequence :
 - in sounding mode (mode 2) it starts with the number of sounding frequencies and is decremented to 1 at the last sounding frequency point.

Status word 0 (identifier step_row)

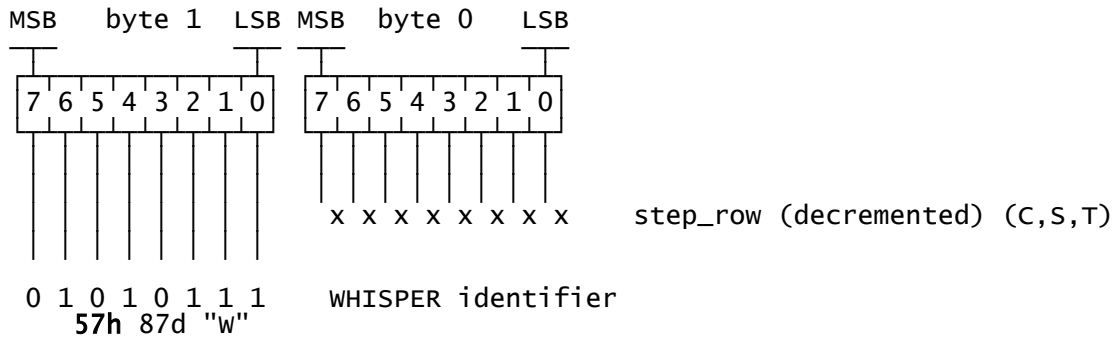

Status word 1 (E_Signal - vsp-scale)

This 16-bit word contains the scale factors given by the VSP after performing an FFT. It echoes if the delayed listening mode is executed. It gives also the position (slice) of the frequency table (fst) set in an active mode ; this could help to identify the running fst.

DWP put a copy of the bit 0 to 4 of byte 1 in the whisper header for sounding modes.

Status word 1

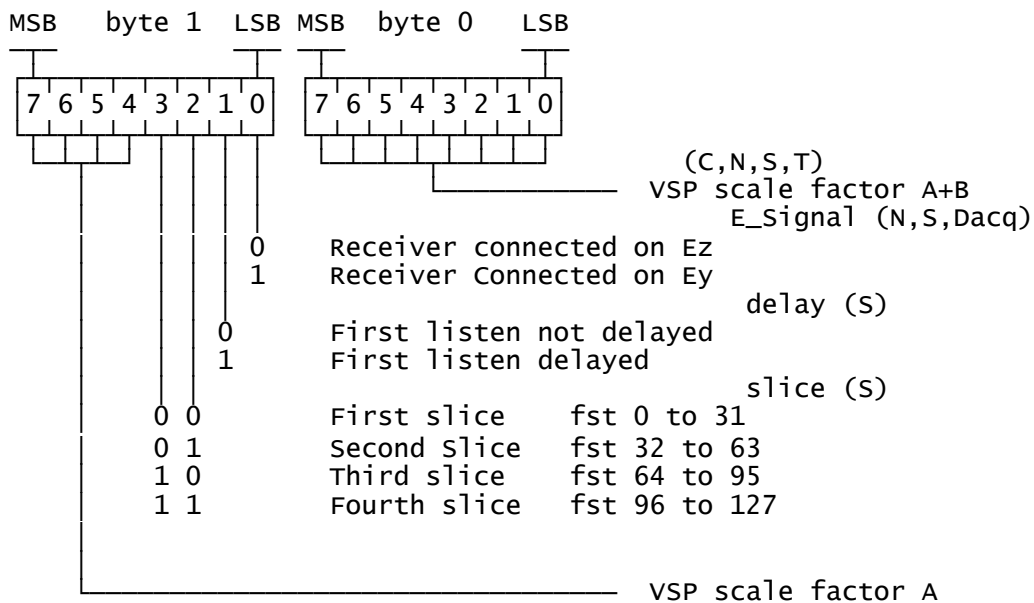

Note : the separate scale factor A and B(not given) are related to the internal process of the FFT and are given for technical information only.

Status word 2 (overf2 - gainmode2)

This 16-bit word contains the number of overflows detected by the related acquisition, this value is an information about the quality of the acquisition. The remaining right bit are related to the instrument operating mode, the receiver gain value, the level of the transmitted pulse, and the calibration level.

Status word 2

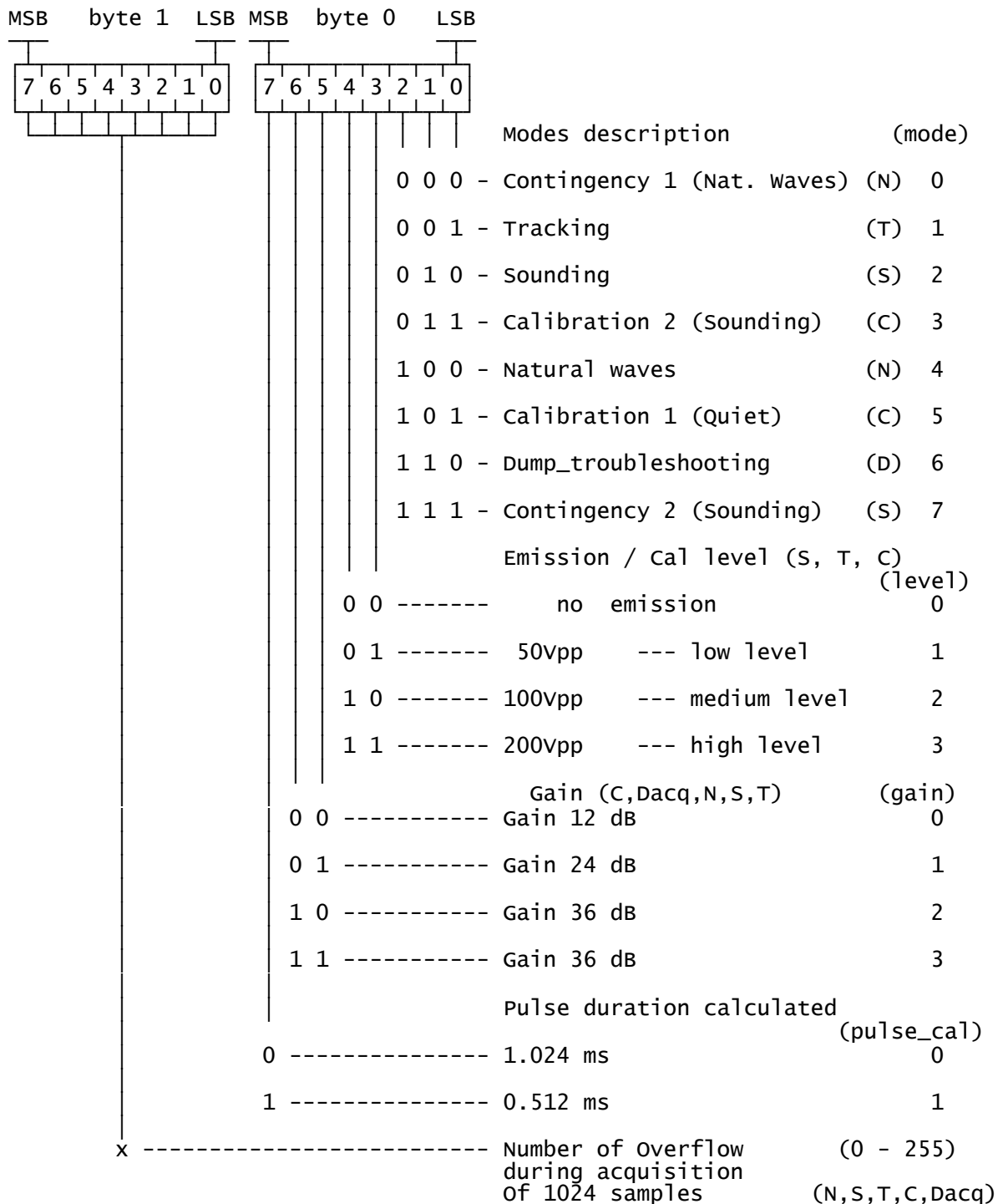

Status word 3 (wd2_rec2_row2)

This 16-bit word contains :

- the value of the watch dog test
- the listen row number (decremented from top value to 1) inside a sounding or tracking step. Top value is the number of R in an active step (smode_aver).
- in natural mode (mode 4) it starts with the number of averages to be performed by the DWP application programme, corresponding to the number of averages set by the (smode_aver) WCMW1 bit 4,5 and 6, and is decremented to 1 at the last frame to be averaged.
- In the gliding mode (in the passive phase) it will be set 127 and decremented.
- In the calibration modes it shows the step number, decremented.

- the repetition row number (decremented) of a sequence according to the repetition factor given in WCMW. At the end of a WHISPER operation it will be set to 1 when it is the last data to be read by the DWP.

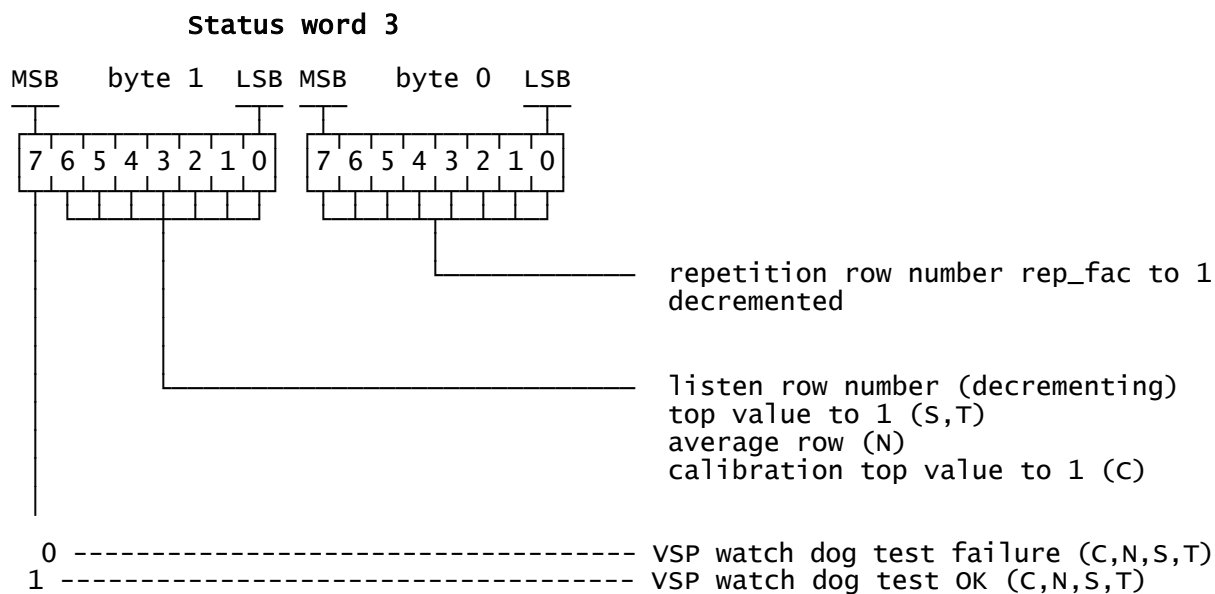

III-4 WHISPER Command Mode word (WCMW) status

The two following experiment status are basically a copy of the WHISPER Command Mode (WCMW). They define the WHISPER operating mode expected by the experimenter. During standard modes operation only few bit is overwritten at the copy time : the frequency point (WCMW byte 3) which is set to the current working frequency in calibration and sounding modes. In these cases, the working frequency is coded in a similar way as for the tracking mode when sending the WCMW.

Status word 4 (WCMW0-WCMW1)

This 16-bit word contains the copy of the WCMW byte 0 and byte 1

Status word 4

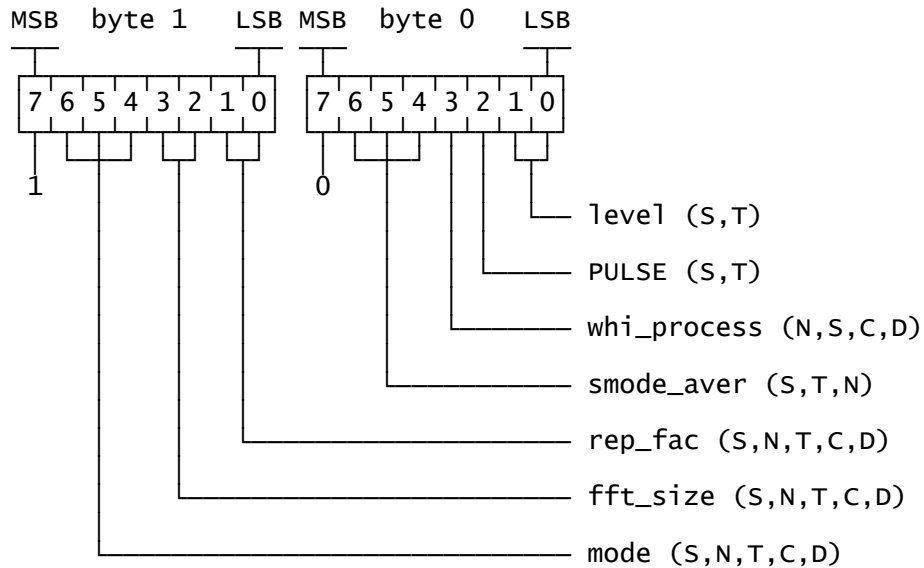

Status word 5 (WCMW2-frequency2)

This 16 bit word contains :
 - the copy of the WCMW byte 2 (word 5 byte 1) or MSB block row + mode (D)
 - the frequency row number of the calibrating, sounding or tracking step (word 5 byte 0).or LSB block row (D).

Status word 5

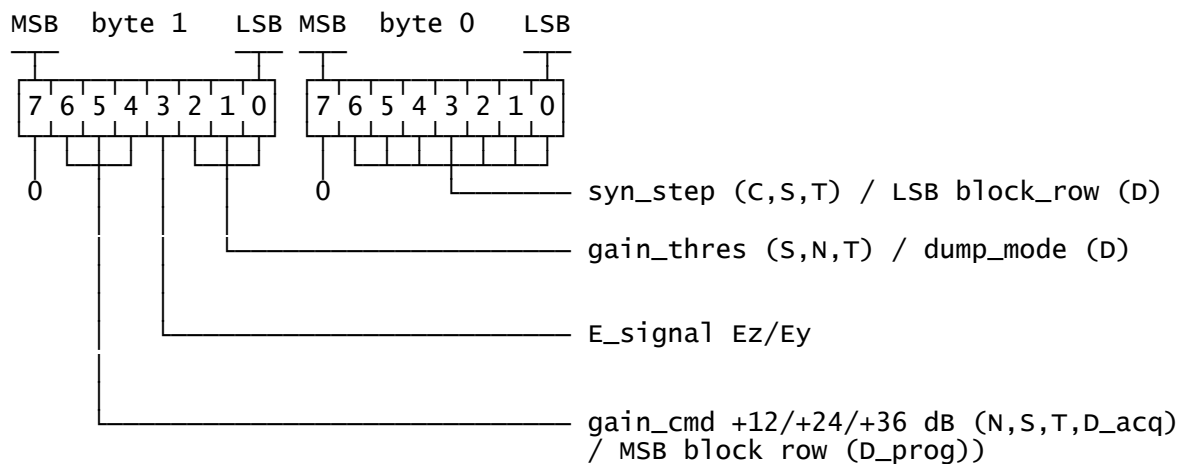

Modes definition (mode)

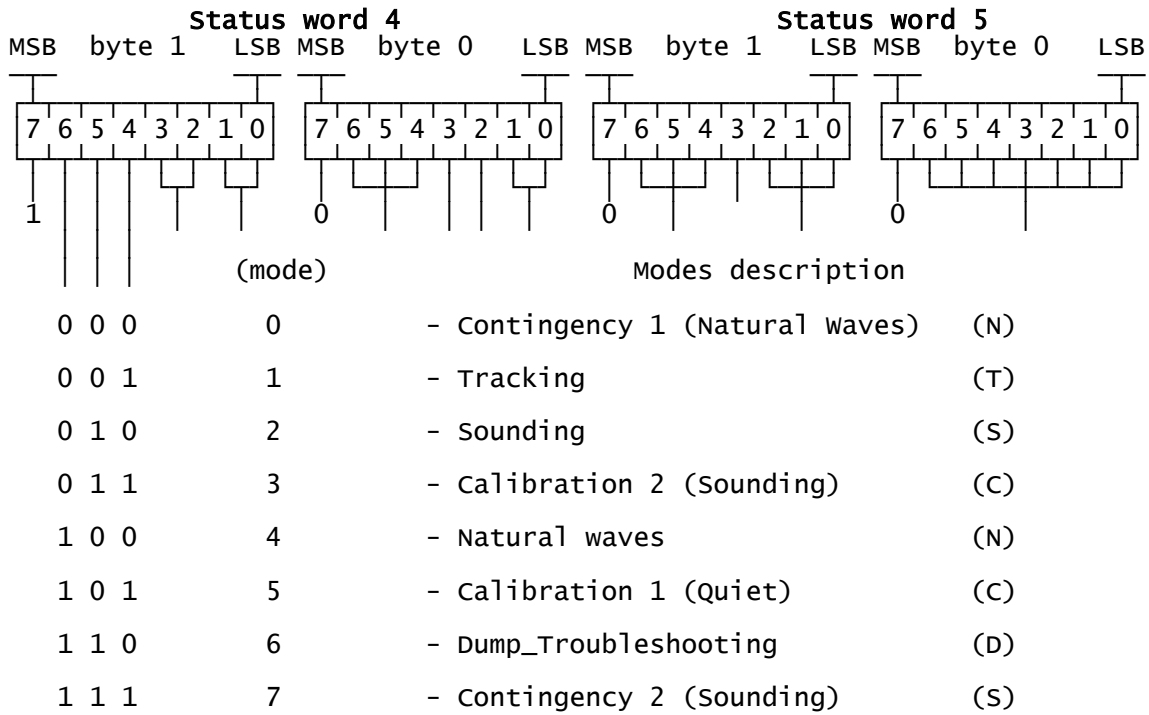

FFT size (fft_size)

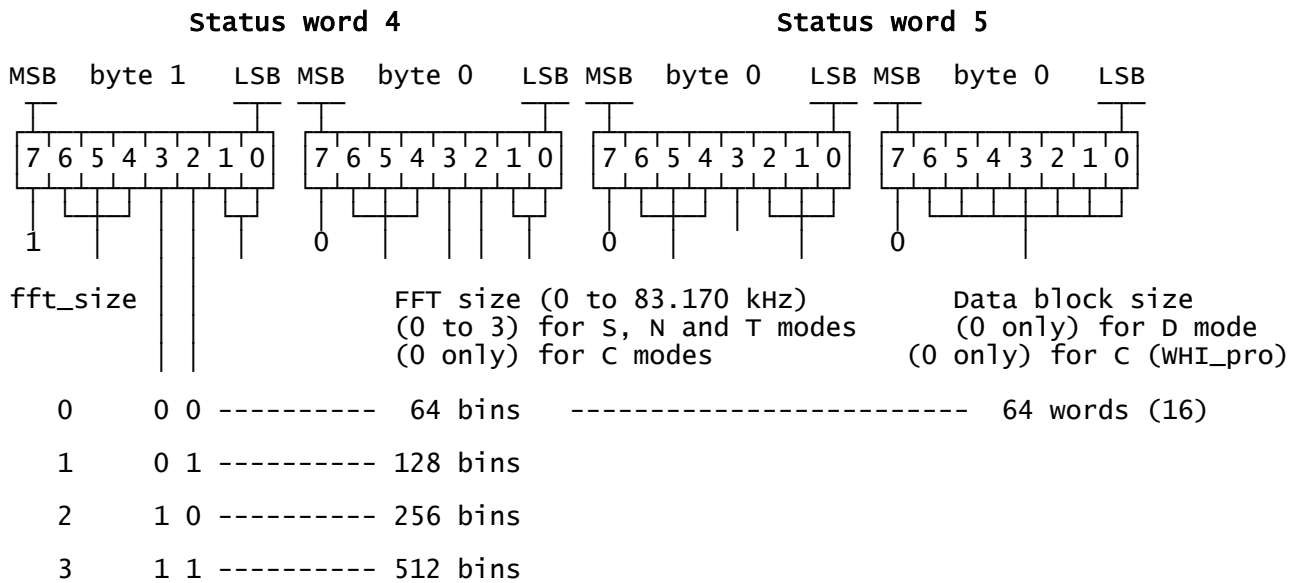

The FFT is applied to the range 0 to 83.170 kHz (fixed sampling frequency, 166.66kHz). Its size, M, defines the frequency resolution lower limit, 83.170/M in kHz. The final resolution may be larger, after processing inside DWP. In a S mode, M will generally be set to 512.

Repetition factor (rep_fac)

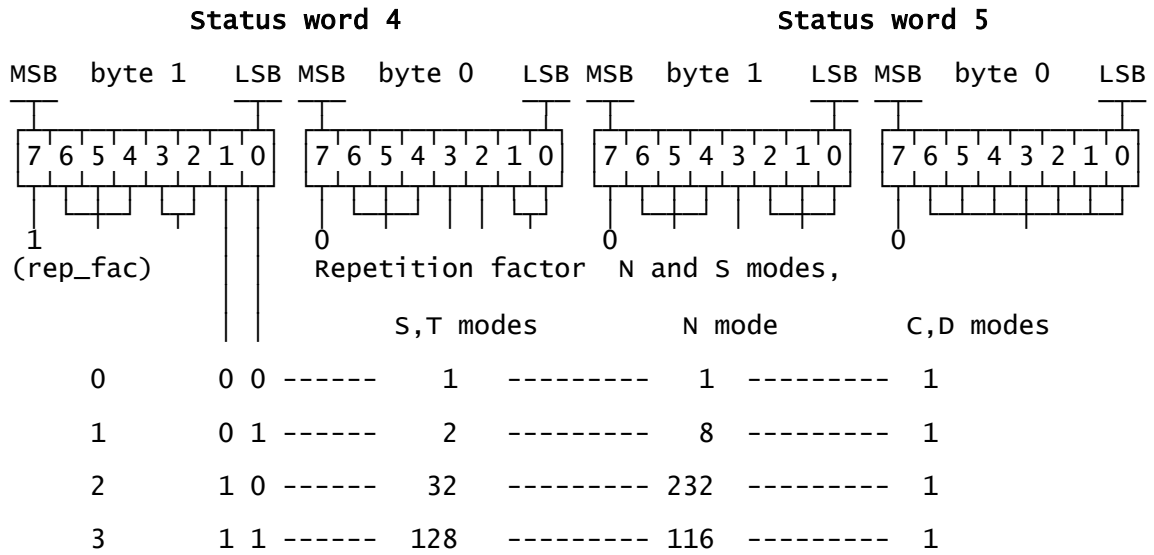

The repetition factor corresponds to the number of time the instrument works in the same configuration. It is one way to limit the sounder operations in case of a mistake or failure in the TC stream. It will also be of use in the definition of duty cycles.

Step duration (smode_aver)

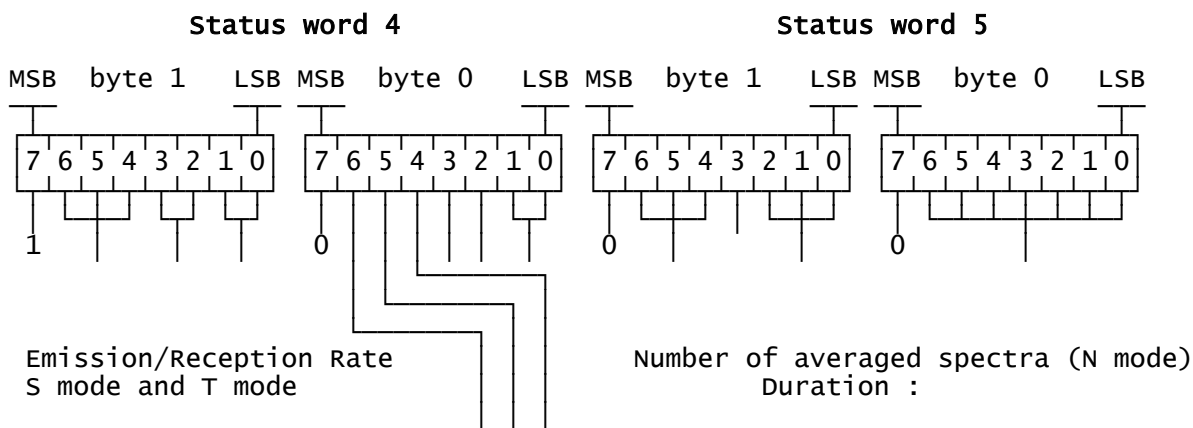

(smode_aver) 0
 1 E 1 R (13.33ms) ----- 0 0 0 --- 32 spectra (426.66ms)

(smode_aver) 1
 1 E 2 R (26.66ms) ----- 0 0 1 --- 16 spectra (213.33ms)

(smode_aver) 2
 1 E 3 R (40ms) ----- 0 1 0 --- 16 spectra (213.33ms)

(smode_aver) 3
 1 E 5 R (66.66ms) ----- 0 1 1 --- 8 spectra (106.66ms)

(smode_aver) 4
 1 E 8 R (106.66ms) ----- 1 0 0 --- 4 spectra (53.33ms)

(smode_aver) 5 (T mode overwritten with smode_aver = 0)
 Gliding mode ----- 1 0 1 --- 2 spectra (26.66ms)

2.125 Spin (8.5s)
 40 x (1E 1R) (533.33ms) | | |
 + A (waiting) (2106.66ms)
 + 256 x 1R (3413.33ms)
 + B (waiting) (2446.66ms adj.) | | |
 455 WHSS requested
 296 frames issued

(smode_aver) 6
 SYNC A Spin/32 (125ms) ----- 1 1 0 --- 64 spectra (853.33ms)

(1E 5R) (80ms)
 + B (waiting) (45ms adj.) | | |
 6 WHSS requested
 5 frames issued

(smode_aver) 7
 SYNC B Spin/16 (250ms) ----- 1 1 1 --- 1 spectrum (13.33ms)

(1E 13) (186.66ms)
 + B (waiting) (63.34ms adj.)
 14 WHSS requested
 13 frames issued

Modes DWP Emergency (whi_process)

If bit 3 of WCMW2 is set, a internal WHISPER processing is requested for tracking mode (mode 1), sounding mode (mode 2), natural waves mode (mode 4) and calibration modes (modes 3 & 5).

Status word 4

Status word 5

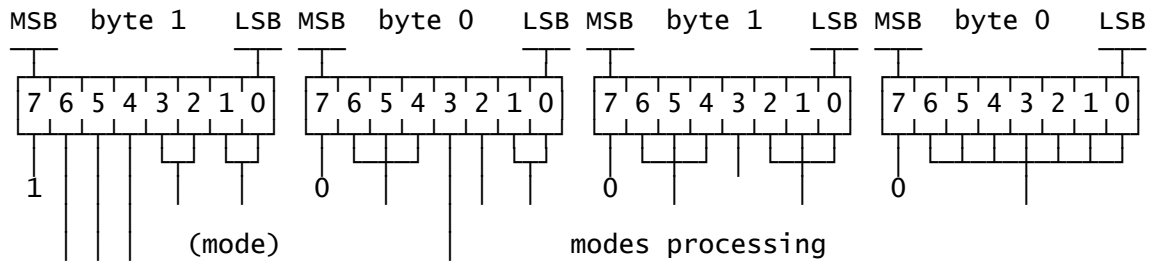

0	0	1	1	(T)	0	- Tracking DWP processing
0	0	1	1	(T)	1	- Tracking WHISPER processing (also used for uploading EEPROM)
0	1	0	2	(S)	0	- Sounding DWP processing
0	1	0	2	(S)	1	- Sounding WHISPER processing
0	1	1	3	(C)	0	- Cal 2 DWP processing
0	1	1	3	(C)	1	- Cal 2 WHISPER processing
1	0	0	4	(N)	0	- Natural waves DWP Processing
1	0	0	4	(N)	1	- Natural waves WHISPER Processing
1	0	1	5	(C)	0	- Cal 1 DWP processing
1	0	1	5	(C)	1	- Cal 1 WHISPER Processing
1	1	0	6	(D)	1	- Dump_Troubleshooting

Pulse duration (PULSE)

Status word 4

Status word 5

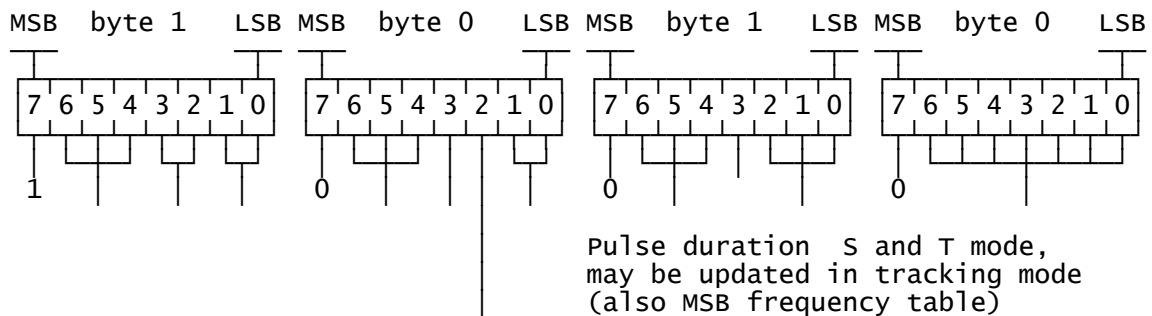

0 ----- Pulse 1.024ms
 1 ----- Pulse 0.512ms

In S modes, the frequency difference between to adjacent steps will be adjusted to the pulse duration : respectively 1 or 2kHz for 1 or 0.5ms. This status bit (word 4 byte 1 bit 6) can be taken into account when interpreting the frequency scan mode bit.

Emission level (level)

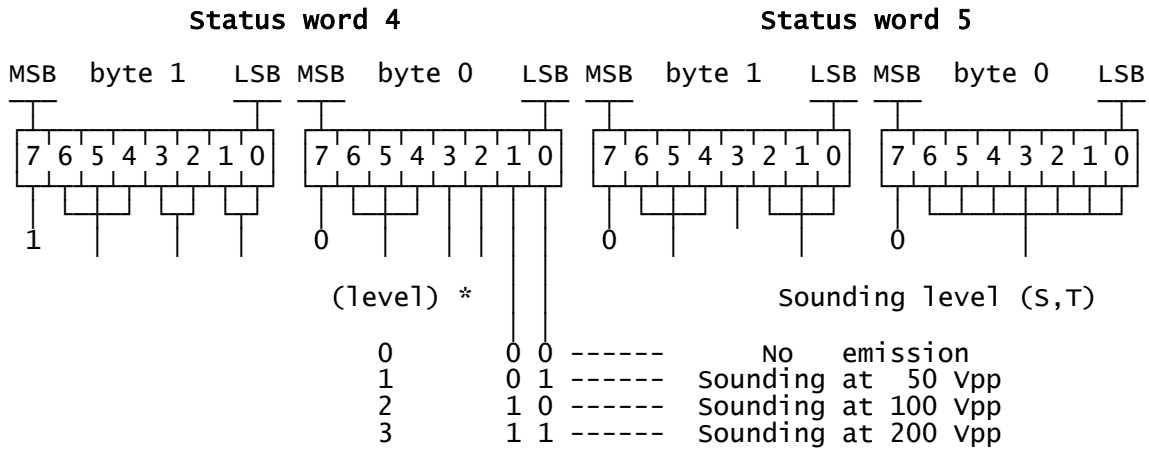

* may be updated in tracking mode
Receiver gain (Gain_cmd)

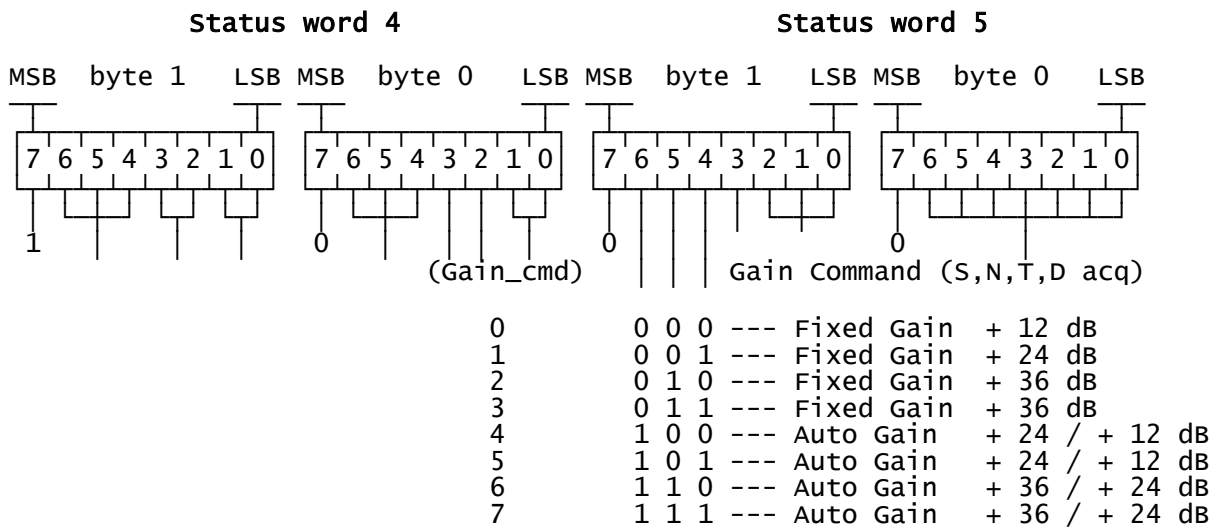

In acq_dump mode, bit 6 is ignored, thus only fixed gain is set.

Receiver Connection (E_signal)

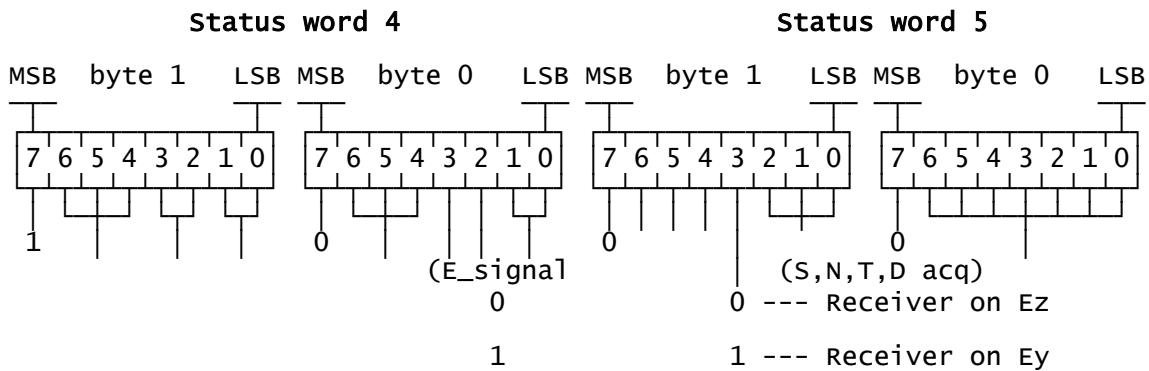

Automatic Gain Threshold (gain_thres)

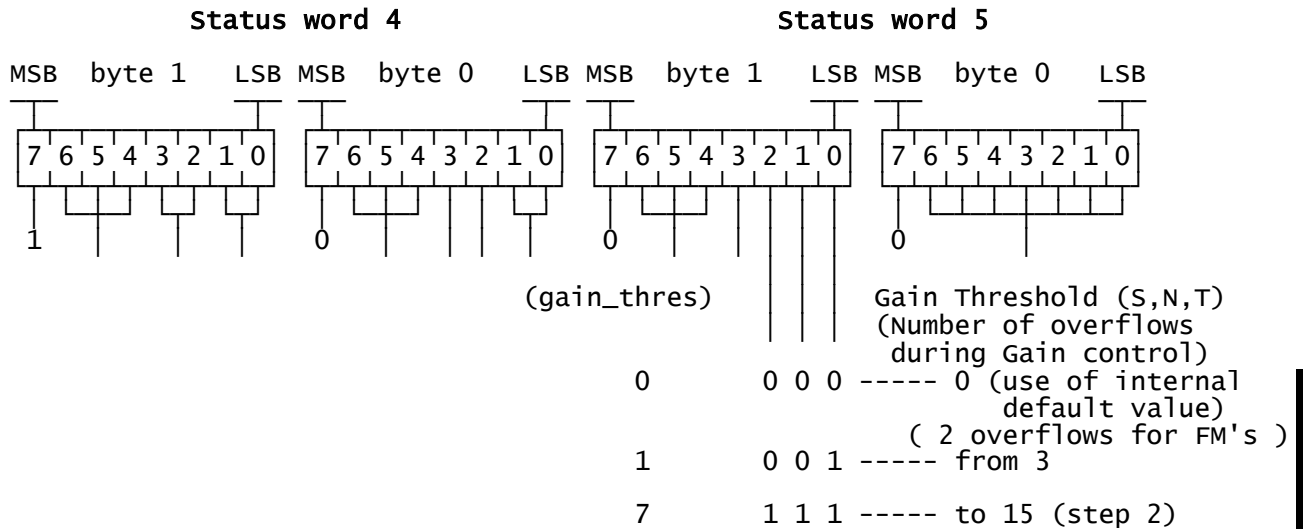

Frequency point/Dump block (fst)

This word gives the frequency point effectively generated in Sounding, Tracking, Calibration and Active Contingency modes.
 In natural modes this word is zeroed.
 In upload, protect and unprotect mode, this word echoes the WCMW3.

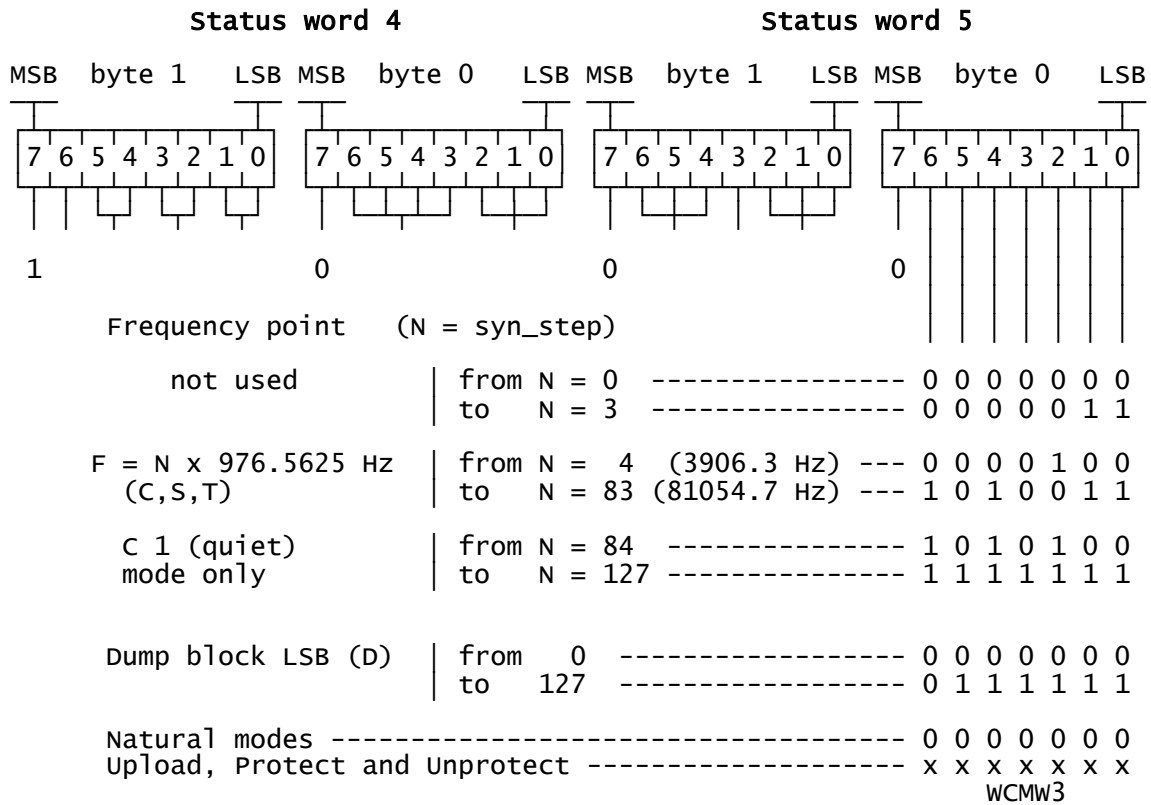

III-5 WHISPER Data Main Words (WDMW)

These 16-bit words contain, during the sounding and natural waves operations, the quadratic sum of the 128 first samples data collected during an acquisition.

According to the `fft_size`, 2, 4, 8, 16 words are set with the energy value corresponding respectively to the 1, 2, 4, 8 blocks of 128 samples. (see table III-8)

Each pair of words is coded as an unsigned integer of 32 bit

For the `fft_size` 64, this 32 bit word is the energy value, for the other `fft_size`, the DWP (application task) will sum 2, 4 or 8 energy (32 bit) to give the corresponding energy value.

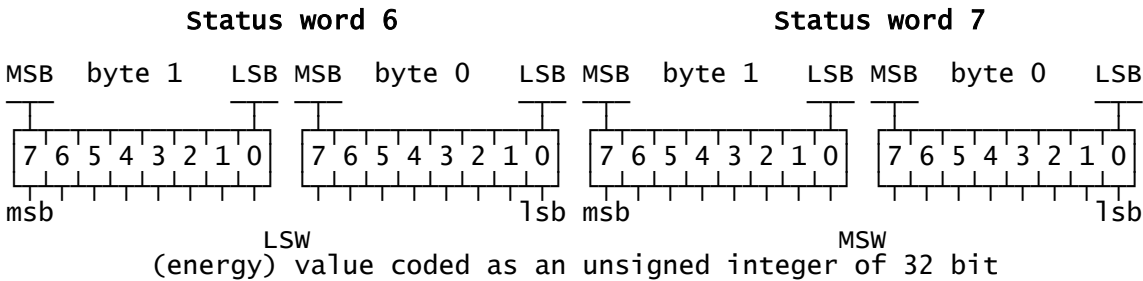

NOTE : LSW (Least Significant Word) is before MSW

- During the calibration modes, without WHISPER Post-Processing, these two words are set in two different ways :

- when no frequency is generated : energy value coded as above.
- when a frequency pulse is generated :
 the words 6 (MSW) and 7 (LSW) contain the amplitude of the bin related to the frequency. The amplitude = raw FFT result X 2exp(scale factor).

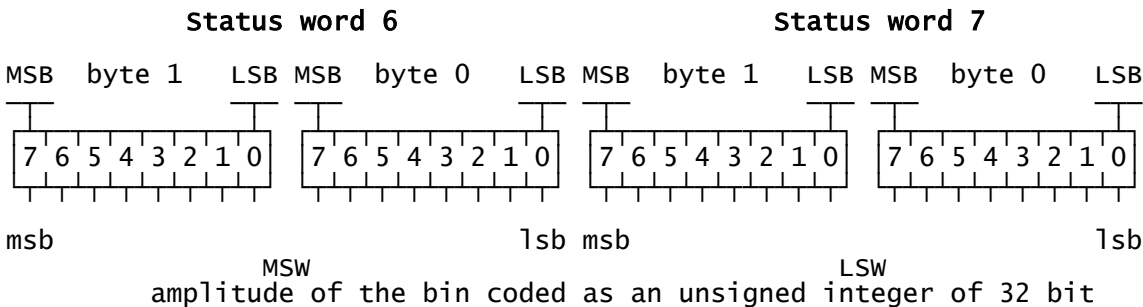

NOTE for CLUSTER 2 :

In the normal modes (DWP or WHI processes) the value of the energy is not anymore shifted by the Zoran processor when the gain changes in automatic gain.

- In the Natural WHISPER internal processing dedicated modes :
- in fixed gain the energy values are not shifted.
 - in automatic gain :
 - gain max -> the energy not shifted
 - gain min -> the energy is shifted left of 4 bit (X 16)

III-6 WHISPER Uploading EEPROM and protect/unprotect Status

Output format for Uploading WHISPER EEPROM (in mode 1)

one 64 words frame is issued at the end of the upload procedure

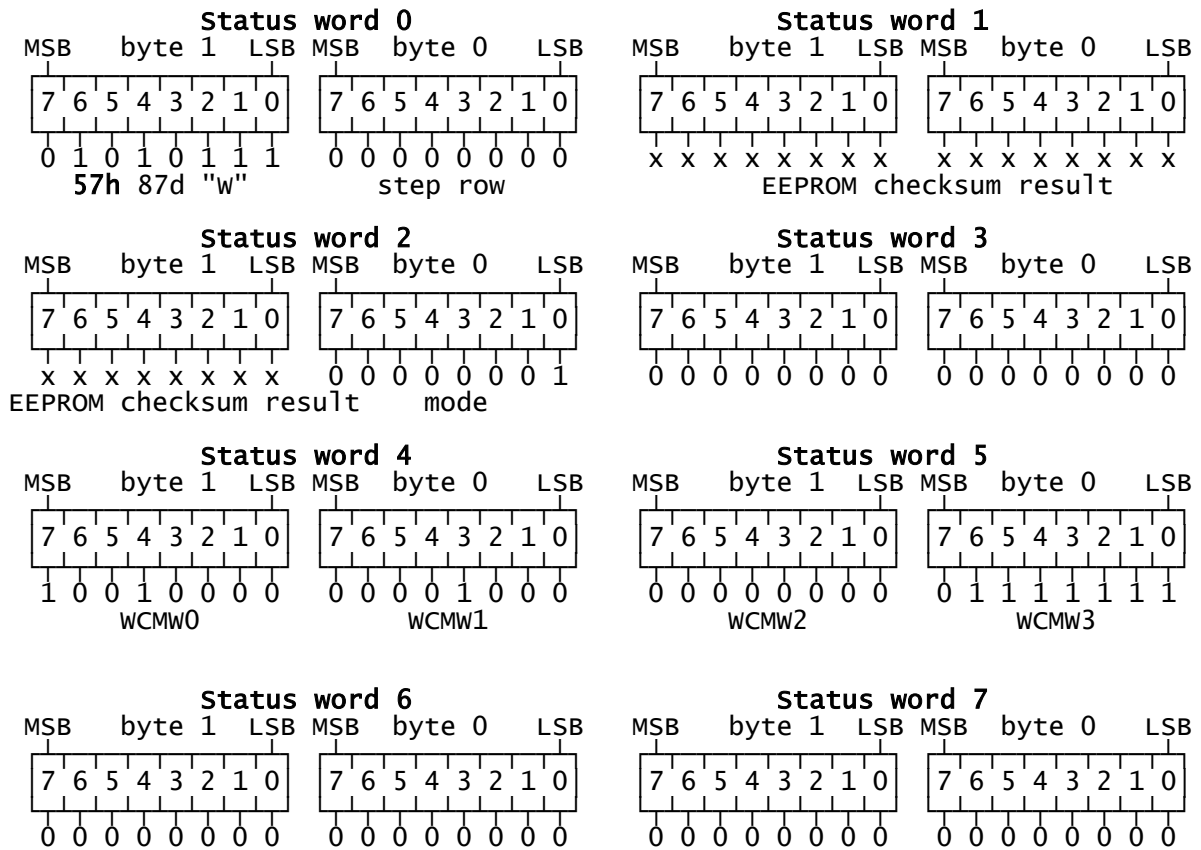

Output format for Protect/Unprotect WHISPER EEPROM (in mode 1)
 one 64 words frame is issued at the end of the upload procedure

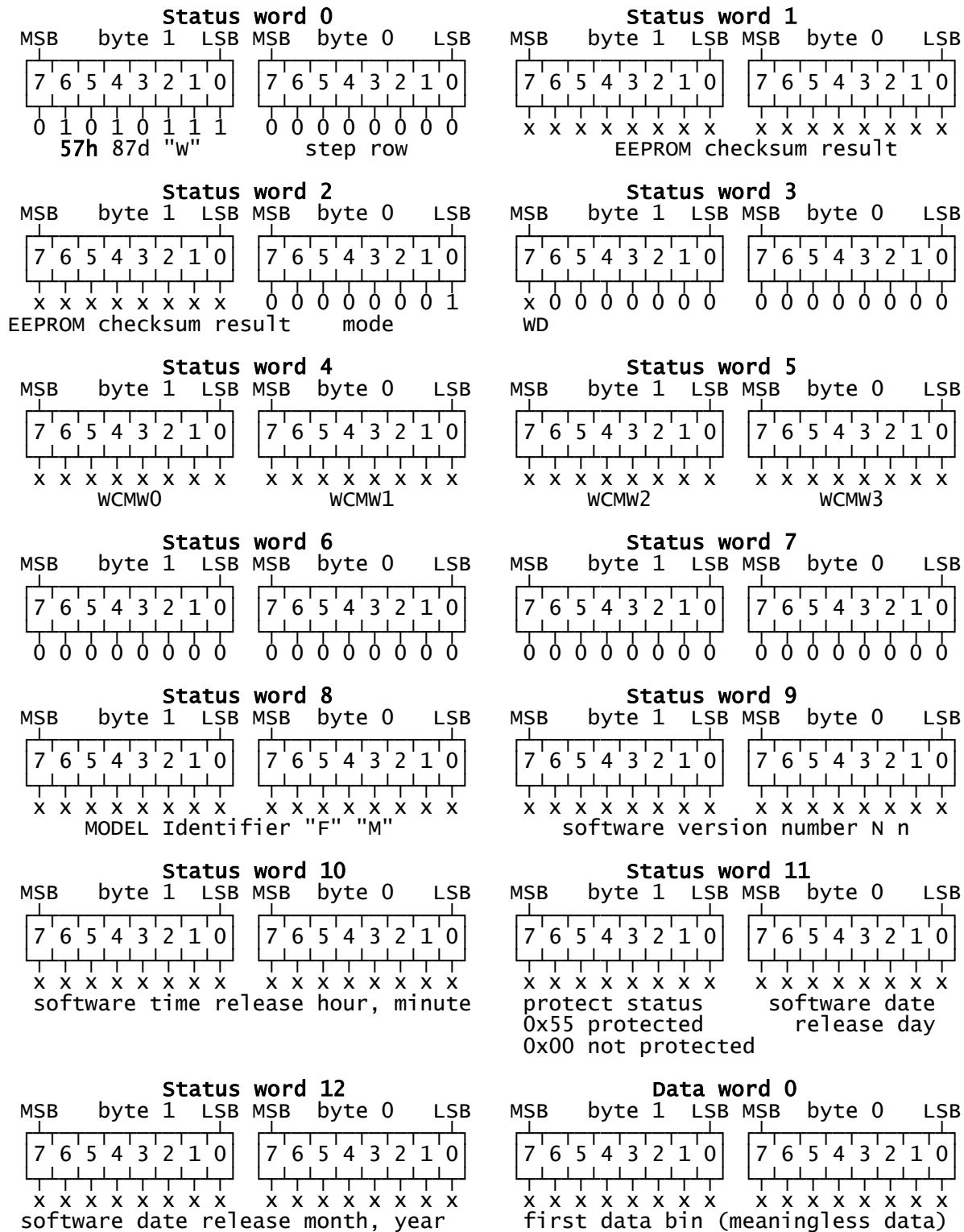

III-7 WHISPER Processed Calibration Mode Words Status

During Calibration modes WHISPER processed, the output data is one frames containing 13 status words (16 bit) and 51 words(16 bit) of data. No data processing is requested by the DWP.

The calibration modes WHISPER processed can by use as an automatic test for WHISPER.

Both passive and active calibration whi_pro modes can be used.

The status word 0 to 5 will be set to the status of the last step of the sequence in case of succes, or will hold the status values of the first step subject to an error.

The status word 6 and word 7 are dedicated as key word for this test. In case of succesful sequence the words 6 and 7 will show : FFFF FFFF
 In case of error during the sequence, the first byte of word 6 will be set according to the error type and the step row. The second byte of word 6, the first byte of word 7 and the second byte of word 7 will be set to the 2nd, 3rd and 4th error accordingly, if any..

For the automatic test the first byte of word 6 can be checked.

Coding of error :

Each step output is evaluated and compared to a built in reference table. Two ranges are defined :

- range 1 : the output is equal to the reference value + or - 3 db
- range 2 : the output is equal to the reference value + or - 6 db

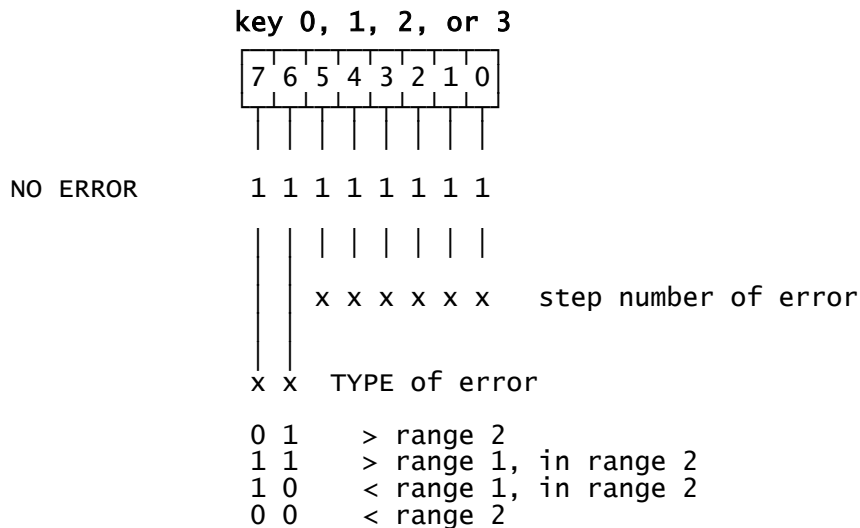

Note : In this mode, the status word 11 byte 1 shows the software protect status. The values are 55h : protection activated otherwise not protected.

Output format for Calibration WHISPER processed modes

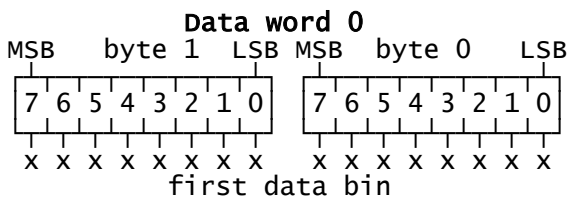
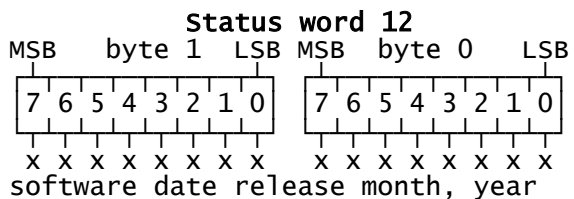
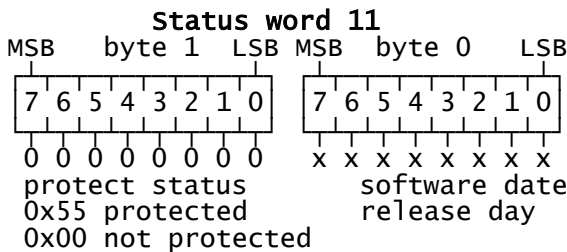
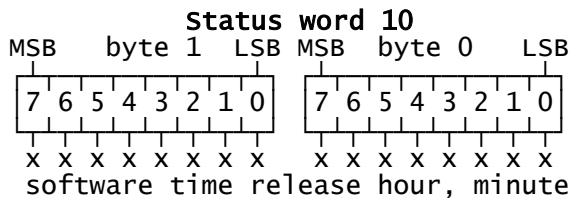
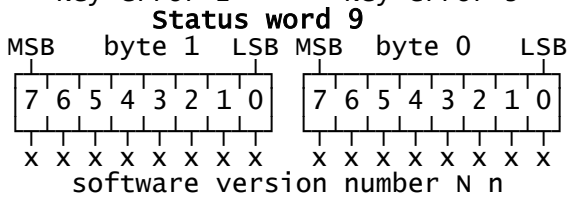
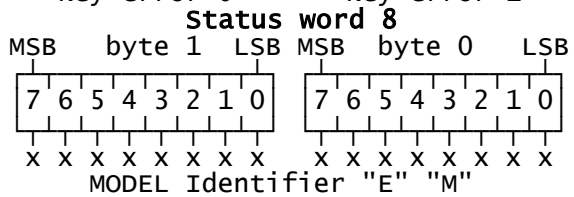
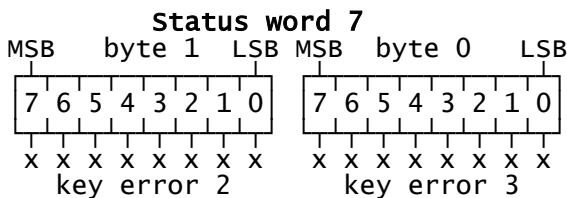
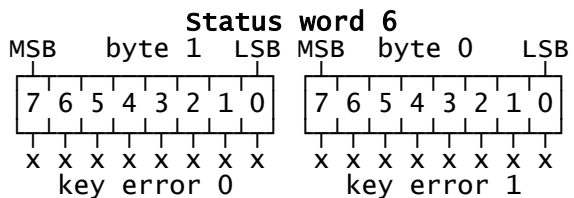
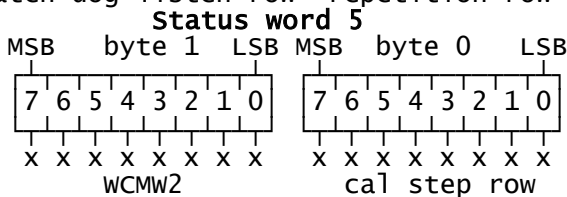
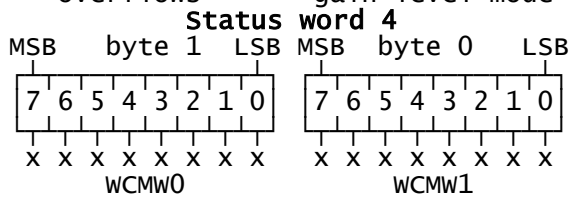
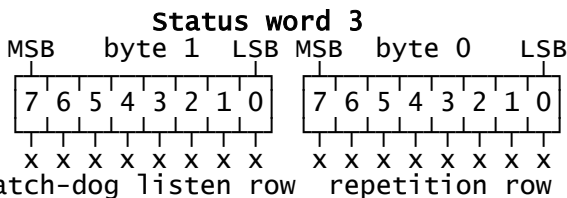
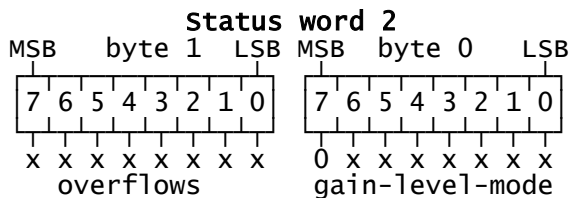
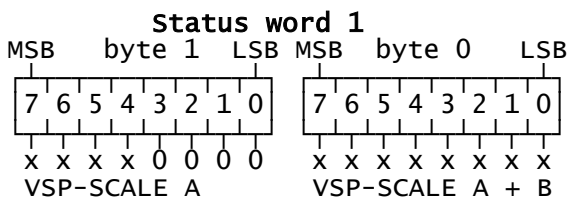
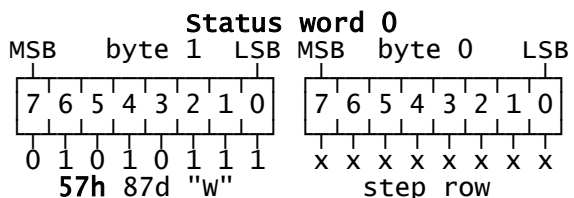

III-8 WHISPER internal processing dedicated modes output format

WHISPER Processed Natural Waves A & B modes

In these modes only one frame per cycle is issued with a format similar to the standard natural wave mode excepted the following restrictions :

- a) step row (status word 0 byte 0) is zeroed,
- b) VSP scale factors A is not set, the E_signal, delay and slice (status word 1 byte 1) are transmitted,
- c) VSP scale factor A + B (global) (status word 1 byte 0) corresponds to the higher scale factor found during one cycle,
- d) number of overflows (status word 2 byte 1) is the averaged number of overflow during a cycle (total number of overflow divided by the number of spectra),
- e) gain/mode (status word 2 byte 0) is the gain/mode status of the last spectrum within a cycle,
- f) VSP watch dog test (status word 3 byte 1 bit 7) is the VSP watch dog test of the last spectrum within one cycle,
- g) listen row (status word 3 byte 1 bit 0 to 6) is set to 1,
- h) repetition row (status word 3 byte 0) is updated according to the running row number (decremented),
- i) the status word 4 and 5 are set as in the standard natural wave mode,
- j) the status word 6 and 7 (energy 0) contain the averaged quadratic sum of the samples collected during one cycle, coded as an unsigned integer 32 bit,
- k) the energy 1 (128 bins) and energy 1 to 3 (256 bins) are zeroed,
- l) the bin amplitudes are given according to the tables in paragraphe III 10, and correspond to the averaged value of each bin, these values are scaled according to the higher VSP scale factor found during the running cycle as given in c),

WHISPER Processed Sounding mode A & B

In these modes only one frame per cycle is issued with a format similar to the standard sounding mode excepted the following restrictions :

- a) step row (status word 0 byte 0) is zeroed,
- b) VSP scale factors A is not set, the E_signal, delay and slice (status word 1 byte 1) are transmitted,
- c) VSP scale factor A + B (global) (status word 1 byte 0) corresponds to the scale factor of the spectrum were the higher bin amplitude was found during one cycle,
- d) number of overflows (status word 2 byte 1) is the number of overflow of the spectrum were the higher bin amplitude was found during one cycle,
- e) gain/mode (status word 2 byte 0) is the gain/mode status of the of the spectrum were the higher bin amplitude was found during one cycle,
- f) VSP watch dog test (status word 3 byte 1 bit 7) is the VSP watch dog test of of the spectrum were the higher bin amplitude was found during one cycle,
- g) listen row (status word 3 byte 1 bit 0 to 6) is set to 0,
- h) repetition row (status word 3 byte 0) is updated according to the running row number (decremented),
- i) the status word 4 byte 1 and byte 5 and word 5 byte 1 are set as in the standard sounding mode (copy of the WCMW0 WCMW1 and WCMW2),
- j) the fst (status word 5 byte 0) gives the frequency point of the spectrum were the higher bin amplitude was found during one cycle,
- k) the status word 6 and 7 (energy 0) contain the averaged quadratic sum of the 128 first samples of the spectrum were the higher bin amplitude was found during one cycle, coded as an unsigned integer 32 bit; the energy 1 to 7 are related to the following samples of the same spectrum,
- l) the bin amplitudes are given according to the tables in paragraphe III 10, the spectrum given for each cycle is rebuilt with six bins of each spectra (the bin corresponding to the sounding frequency plus the two preceding bins and the three following bins) the amplitude of the bins are scaled according to the vsp scale factor of the spectrum were the higher bin amplitude was found during one cycle; unused bins 12 to 21 (word 21 to 30) are zeroed.

NOTE : In mode B, a delay of one WHSS (13.33ms) is applied to the first listen step after the sounding pulse.

III-9 WHISPER Trouble shooting Mode Words (WTMW) Status

During trouble shooting modes, the output data frames contains six 16-bit status words and 116 8-bit data words. Data words are coded either as 8-bit or 16-bit unsigned integers. No data processing at all is performed on these data neither by WHIPSER nor the DWP.

The first four words (words 0-3) describe the operating mode actually running. They are the WHISPER Actual Mode status Words called WAMW. The first byte of the first status word is a fix identifier which contains the ASCII value of the first letter "W" from WHISPER. These status are not the same as for science modes.

The words 4 and 5 byte 1 receive a copy of the WHISPER Command Mode word (WCMW bytes 0,1 and 2). WCMW byte 2 may be partly overwritten. Status words 4 and 5 form the WHISPER Command Mode status words called WCMW.

The number of frames required to performed the dump of a internal memory is given below in the status definitions.

Acquisition Dump Mode words Status

- status word 0 byte 1 contains a fix identifier which is the ASCII value of the first letter "w" from WHISPER,
- status word 0 byte 0 is zeroed.
- status word 1 byte 0 bit 0 is antenna connection other are zeroed.
- status word 2 byte 1 contains the number of overflow.
- status word 2 byte 0 contains the designation of the current dump operation.
- status word 3 is zeroed but byte 0 bit 8 which contains the Watch Dog status.
- status word 4 and 5 byte 1 contain a copy of the WCMW received by WHISPER.
- status word 5 byte 0 is the block row coded as a 8-bit unsigned integer.

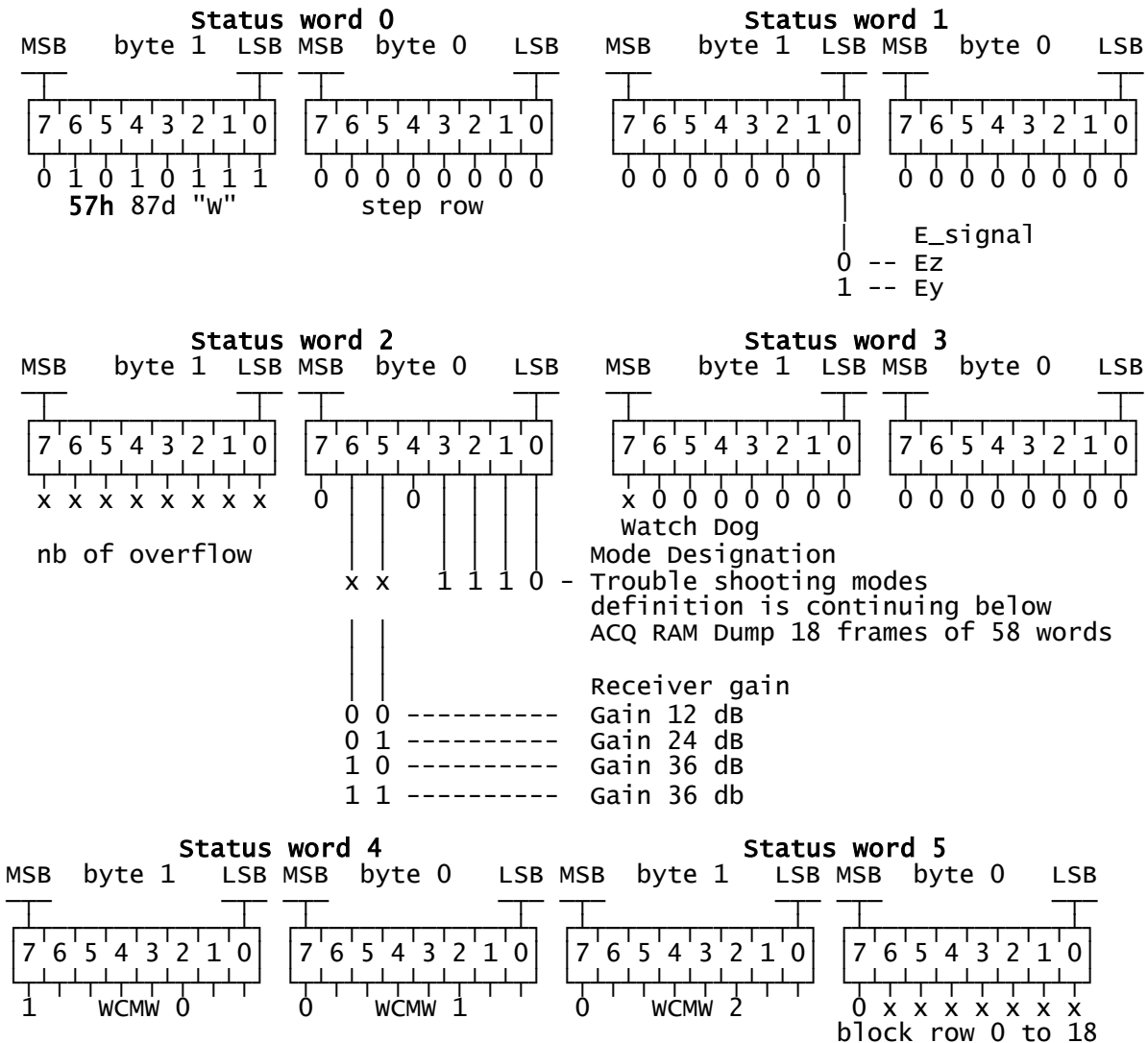

Programme Dump Mode Words Status

During Troubleshooting modes dedicated to the dump of program memories, the instrument performs additional memory check sums to verify the integrity of its program. Check sum values are included in the status words.

- status word 0 byte 1 contains a fix identifier which is the ASCII value of the first letter "w" from WHISPER;
- status word 0 byte 0 is zeroed.
- status words 1 and status word 2 byte 1 contain a numeric check sum value related to the memory under consideration according to status word 2 byte 0; It is the part result in the checksum calculation which is calculated by adding the checksums of the individual 58-words data block already dumped. It is a 3-bytes words coded as a 24-bit unsigned integer which represents the memory checksum when associated with the last data block.
- status word 2 byte 0 contains the current dump operation.
- status word 3 byte 0 and byte 1 bit 1 to 7 contains the numeric checksum value of the data block in the output memory, bit 8 contains the Watch Dog status.
- status word 4 and 5 byte 1 contain a copy of the WCMW received by WHISPER.
- status word 5 bit 4,5 and 6 are overwritten and contain the Most Significant Part of the block row
- status word 5 byte 0 is a the Least Significant Part of the block row. The block row is coded as a 10-bit unsigned integer.

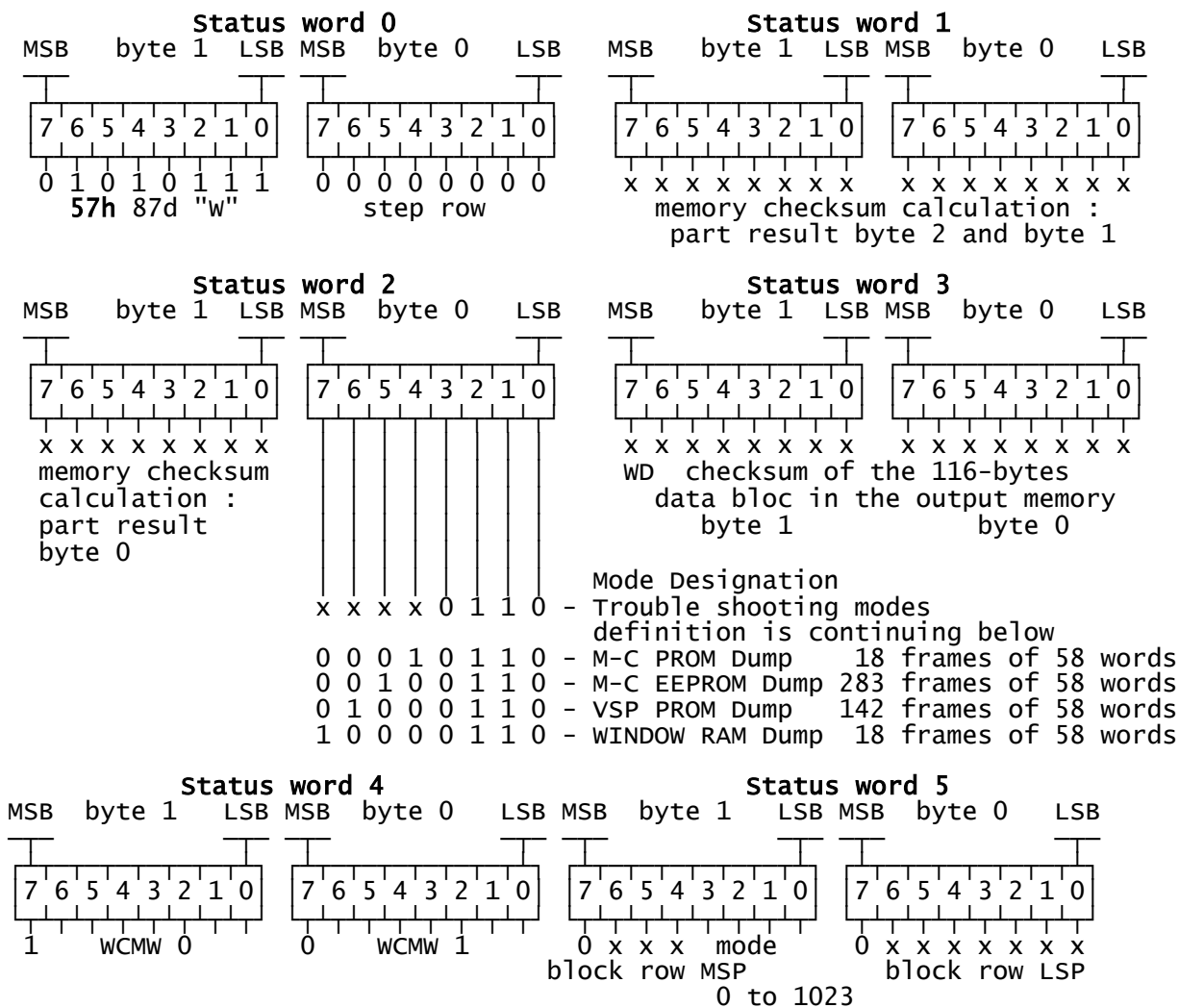

III-10 Output data frame

The data but the status and energy words are coded as 16 bit two's complement integer

c : denotes active calibration frequency,

s : denotes sounding synthesizer step,

— : denotes the last bin read by DWP.

Center frequency (kHz)

word	64 bins	word	64 bins
0	Status 0-----	44	52.083
1	Status 1-----	45	53.385
2	Status 2-----	46	54.688
3	Status 3-----	47	55.990
4	Status 4-----	48	57.292
5	Status 5-----	49	58.594
6	energy 0 LSW	50	59.896
7	energy 0 MSW	51	61.198
8	5.208 bin 4	52	62.500 c 64
9	6.510	53	63.802
10	7.812 c 8	54	65.104
11	9.115	55	66.406
12	10.417	56	67.708
13	11.719 c 12	57	69.010 (97.656)
14	13.021	58	70.312 c 72
15	14.323	59	71.615
16	15.625 c 16	60	72.917
17	16.927	61	74.219 c 76
18	18.229	62	75.521
19	19.531	63	<u>76.823</u>
20	20.833	64	
21	22.135	65	
22	23.438 c 24	66	
23	24.740	67	
24	26.042	68	
25	27.344	69	
26	28.646	70	
27	29.948	71	(97.656) c 100
28	31.250	72	
29	32.552	73	
30	33.854	74	
31	35.156 c 36	75	
32	36.458	76	
33	37.760	77	
34	39.062	78	
35	40.365	79	
36	41.667	80	
37	42.969 c 44	81	
38	44.271	82	
39	45.573 (121.094)	83	
40	46.875	84	
41	48.177	85	
42	49.479	86	
43	50.781 c 52	87	
		88	(121.094) c 124

word	128 bins	word	128 bins
0	Status 0	56	32.552
1	Status 1	57	33.203
2	Status 2	58	33.854
3	Status 3	59	34.505
4	Status 4	60	35.156
5	Status 5	61	35.807
6	energy 0 LSW	62	36.458
7	energy 0 MSW	63	37.109
8	energy 1 LSW	64	37.760
9	energy 1 MSW	65	38.411
10	2.604 bin 4	66	39.062
11	3.255	67	39.714
12	3.906	68	40.365
13	4.557	69	41.016
14	5.208	70	41.667
15	5.859	71	42.318
16	6.510	72	42.969
17	7.161	73	43.620
18	7.812	74	44.271
19	8.464	75	44.922
20	9.115	76	45.573
21	9.766	77	46.224
22	10.417	78	46.875
23	11.068	79	47.526
24	11.719	80	48.177
25	12.370	81	48.828
26	13.021	82	49.479
27	13.672	83	50.130
28	14.323	84	50.781
29	14.974	85	51.432
30	15.625	86	52.083
31	16.276	87	52.734
32	16.927	88	53.385
33	17.578	89	54.036
34	18.229	90	54.688
35	18.880	91	55.339
36	19.531	92	55.990
37	20.182	93	56.641
38	20.833	94	57.292
39	21.484	95	57.943
40	22.135	96	58.594
41	22.786	97	59.245
42	23.438	98	59.896
43	24.089	99	60.547
44	24.740	100	61.198
45	25.391	101	61.849
46	26.042	102	62.500
47	26.693 48	103	63.151
27.344		104	63.802
49	27.995	105	64.453
50	28.646	106	65.104
51	29.297	107	65.755
52	29.948	108	66.406
53	30.599	109	67.057
54	31.250	110	67.708
55	31.901	111	68.359
word	128 bins	word	128 bins
		120	74.219
		121	74.870

112	69.010	122	75.521
113	69.661	123	76.172
114	70.312	124	76.823
115	70.964	125	77.474
116	71.615	126	78.125
117	72.266	127	78.776
118	72.917		
119	73.568		

word	256 bins	word	256 bins
0	Status 0	51	13.997
1	Status 1	52	14.323
2	Status 2	53	14.648
3	Status 3	54	14.974
4	Status 4	55	15.299
5	Status 5	56	15.625
6	energy 0 LSW	57	15.951
7	energy 0 MSW	58	16.276
8	energy 1 LSW	59	16.602
9	energy 1 MSW	60	16.927
10	energy 2 LSW	61	17.253
11	energy 2 MSW	62	17.578
12	energy 3 LSW	63	17.904
13	energy 3 MSW	64	18.229
14	1.953 bin 6	65	18.555
15	2.279	66	18.880
16	2.604	67	19.206
17	2.930	68	19.531
18	3.255	69	19.857
19	3.581	70	20.182
20	3.906	71	20.508
21	4.232	72	20.833
22	4.557	73	21.159
23	4.883	74	21.484
24	5.208	75	21.810
25	5.534	76	22.135
26	5.859	77	22.461
27	6.185	78	22.786
28	6.510	79	23.112
29	6.836	80	23.438
30	7.161	81	23.763
31	7.487	82	24.089
32	7.812	83	24.414
33	8.138	84	24.740
34	8.464	85	25.065
35	8.789	86	25.391
36	9.115	87	25.716
37	9.440	88	26.042
38	9.766	89	26.367
39	10.091	90	26.693
40	10.417	91	27.018
41	10.742	92	27.344
42	11.068	93	27.669
43	11.393	94	27.995
44	11.719	95	28.320
45	12.044	96	28.646
46	12.370	97	28.971
47	12.695	98	29.297
48	13.021	99	29.622
49	13.346	100	29.948
50	13.672	101	30.273

word	256 bins	word	256 bins
102	30.599	151	46.549
103	30.924	152	46.875
104	31.250	153	47.201
105	31.576	154	47.526
106	31.901	155	47.852
107	32.227	156	48.177
108	32.552	157	48.503
109	32.878	158	48.828
110	33.203	159	49.154
111	33.529	160	49.479
112	33.854	161	49.805
113	34.180	162	50.130
114	34.505	163	50.456
115	34.831	164	50.781
116	35.156	165	51.107
117	35.482	166	51.432
118	35.807	167	51.758
119	36.133	168	52.083
120	36.458	169	52.409
121	36.784	170	52.734
122	37.109	171	53.060
123	37.435	172	53.385
124	37.760	173	53.711
125	38.086	174	54.036
126	38.411	175	54.362
127	38.737	176	54.688
128	39.062	177	55.013
129	39.388	178	55.339
130	39.714	179	55.664
131	40.039	180	55.990
132	40.365	181	56.315
133	40.690	182	56.641
134	41.016	183	56.966
135	41.341	184	57.292
136	41.667	185	57.617
137	41.992	186	57.943
138	42.318	187	58.268
139	42.643	188	58.594
140	42.969	189	58.919
141	43.294	190	59.245
142	43.620	191	59.570
143	43.945	192	59.896
144	44.271	193	60.221
145	44.596	194	60.547
146	44.922	195	60.872
147	45.247	196	61.198
148	45.573	197	61.523
149	45.898	198	61.849
150	46.224	199	62.174

word	256 bins		
200	62.500	228	71.615
201	62.826	229	71.940
202	63.151	230	72.266
203	63.477	231	72.591
204	63.802	232	72.917
205	64.128	233	73.242
206	64.453	234	73.568
207	64.779	235	73.893
208	65.104	236	74.219
209	65.430	237	74.544
210	65.755	238	74.870
211	66.081	239	75.195
212	66.406	240	75.521
213	66.732	241	75.846
214	67.057	242	76.172
215	67.383	243	76.497
216	67.708	244	76.823
217	68.034	245	77.148
218	68.359	246	77.474
219	68.685	247	77.799
220	69.010	248	78.125
221	69.336	249	78.451
222	69.661	250	78.776
223	69.987	251	79.102
224	70.312	252	79.427
225	70.638	253	79.753
226	70.964	254	80.078
227	71.289	255	80.404

word 512 bins

0	Status	0		
1	Status	1		
2	Status	2		
3	Status	3		
4	Status	4		
5	Status	5		
6	energy	0	LSW	
7	energy	0	MSW	
8	energy	1	LSW	
9	energy	1	MSW	
10	energy	2	LSW	
11	energy	2	MSW	
12	energy	3	LSW	
13	energy	3	MSW	
14	energy	4	LSW	
15	energy	4	MSW	
16	energy	5	LSW	
17	energy	5	MSW	
18	energy	6	LSW	
19	energy	6	MSW	
20	energy	7	LSW	
21	energy	7	MSW	
22	1.953	bin	12	
23	2.116			
24	2.279			
25	2.441			
26	2.604			
27	2.767			
28	2.930			
29	3.092			
30	3.255			
31	3.418			
32	3.581			
33	3.743			
34	3.906	s	4	
35	4.069			
36	4.232			
37	4.395			
38	4.557			
39	4.720			
40	4.883	s	5	
41	5.046			
42	5.208			
43	5.371			
44	5.534			
45	5.697			
46	5.859	s	6	
47	6.022			
48	6.185			
49	6.348			
50	6.510			
word	512 bins		56	7.487
			57	7.650
51	6.673		58	7.812
52	6.836	s	59	7.975
53	6.999		60	8.138
54	7.161		61	8.301
55	7.324		62	8.464

63	8.626	
64	8.789	s 9
65	8.952	
66	9.115	
67	9.277	
68	9.440	
69	9.603	
70	9.766	s 10
71	9.928	
72	10.091	
73	10.254	
74	10.417	
75	10.579	
76	10.742	s 11
77	10.905	
78	11.068	
79	11.230	
80	11.393	
81	11.556	
82	11.719	s 12
83	11.882	
84	12.044	
85	12.207	
86	12.370	
87	12.533	
88	12.695	s 13
89	12.858	
90	13.021	
91	13.184	
92	13.346	
93	13.509	
94	13.672	s 14
95	13.835	
96	13.997	
97	14.160	
98	14.323	
99	14.486	
100	14.648	s 15
101	14.811	

word	512 bins		
102	14.974		
103	15.137		
104	15.299		
105	15.462		
106	15.625	s 16	
107	15.788		
108	15.951		
109	16.113		
110	16.276		
111	16.439		
112	16.602	s 17	
113	16.764		
114	16.927		
115	17.090		
116	17.253		
117	17.415		
118	17.578	s 18	
119	17.741		
120	17.904		
121	18.066		
122	18.229		
123	18.392		
124	18.555	s 19	
125	18.717		
126	18.880		
127	19.043		
128	19.206		
129	19.368		
130	19.531	s 20	
131	19.694		
132	19.857		
133	20.020		
134	20.182		
135	20.345		
136	20.508	s 21	
137	20.671		
138	20.833		
139	20.996		
140	21.159		
141	21.322		
142	21.484	s 22	
143	21.647		
144	21.810		
145	21.973		
146	22.135		
147	22.298		
148	22.461	s 23	
149	22.624		
150	22.786		
word	512 bins	158	24.089
		159	24.251
151	22.949	160	24.414 s 25
152	23.112	161	24.577
153	23.275	162	24.740
154	23.438 s 24	163	24.902
155	23.600	164	25.065
156	23.763	165	25.228
157	23.926	166	25.391 s 26

167	25.553	
168	25.716	
169	25.879	
170	26.042	
171	26.204	
172	26.367	s 27
173	26.530	
174	26.693	
175	26.855	
176	27.018	
177	27.181	
178	27.344	s 28
179	27.507	
180	27.669	
181	27.832	
182	27.995	
183	28.158	
184	28.320	s 29
185	28.483	
186	28.646	
187	28.809	
188	28.971	
189	29.134	
190	29.297	s 30
191	29.460	
192	29.622	
193	29.785	
194	29.948	
195	30.111	
196	30.273	s 31
197	30.436	
198	30.599	
199	30.762	

word	512 bins
200	30.924
201	31.087
202	31.250 s 32
203	31.413
204	31.576
205	31.738
206	31.901
207	32.064
208	32.227 s 33
209	32.389
210	32.552
211	32.715
212	32.878
213	33.040
214	33.203 s 34
215	33.366
216	33.529
217	33.691
218	33.854
219	34.017
220	34.180 s 35
221	34.342
222	34.505
223	34.668
224	34.831
225	34.993
226	35.156 s 36
227	35.319
228	35.482
229	35.645
230	35.807
231	35.970
232	36.133 s 37
233	36.296
234	36.458
235	36.621
236	36.784
237	36.947
238	37.109 s 38
239	37.272
240	37.435
241	37.598
242	37.760
243	37.923
244	38.086 s 39
245	38.249
246	38.411
247	38.574
248	38.737
249	38.900
250	39.062 s 40
word	512 bins
251	39.225
252	39.388
253	39.551
254	39.714
255	39.876

256	40.039 s 41
257	40.202
258	40.365
259	40.527
260	40.690
261	40.853
262	41.016 s 42

263	41.178	
264	41.341	
265	41.504	
266	41.667	
267	41.829	
268	41.992	s 43
269	42.155	
270	42.318	
271	42.480	
272	42.643	
273	42.806	
274	42.969	s 44
275	43.132	
276	43.294	
277	43.457	
278	43.620	
279	43.783	
280	43.945	s 45
281	44.108	
282	44.271	
283	44.434	
284	44.596	
285	44.759	
286	44.922	s 46
287	45.085	
288	45.247	
289	45.410	
290	45.573	
291	45.736	
292	45.898	s 47
293	46.061	
294	46.224	
295	46.387	
296	46.549	
297	46.712	
298	46.875	s 48
299	47.038	
300	47.201	
301	47.363	

word	512 bins		
302	47.526		
303	47.689		
304	47.852	s 49	
305	48.014		
306	48.177		
307	48.340		
308	48.503		
309	48.665		
310	48.828	s 50	
311	48.991		
312	49.154		
313	49.316		
314	49.479		
315	49.642		
316	49.805	s 51	
317	49.967		
318	50.130		
319	50.293		
320	50.456		
321	50.618		
322	50.781	s 52	
323	50.944		
324	51.107		
325	51.270		
326	51.432		
327	51.595		
328	51.758	s 53	
329	51.921		
330	52.083		
331	52.246		
332	52.409		
333	52.572		
334	52.734	s 54	
335	52.897		
336	53.060		
337	53.223		
338	53.385		
339	53.548		
340	53.711	s 55	
341	53.874		
342	54.036		
343	54.199		
344	54.362		
345	54.525		
346	54.688	s 56	
347	54.850		
348	55.013		
349	55.176		
350	55.339		
word	512 bins		
		358	56.641 s 58
		359	56.803
351	55.501	360	56.966
352	55.664	361	57.129
353	55.827	362	57.292
354	55.990	363	57.454
355	56.152	364	57.617 s 59
356	56.315	365	57.780
357	56.478	366	57.943

367	58.105	
368	58.268	
369	58.431	
370	58.594	s 60
371	58.757	
372	58.919	
373	59.082	
374	59.245	
375	59.408	
376	59.570	s 61
377	59.733	
378	59.896	
379	60.059	
380	60.221	
381	60.384	
382	60.547	s 62
383	60.710	
384	60.872	
385	61.035	
386	61.198	
387	61.361	
388	61.523	s 63
389	61.686	
390	61.849	
391	62.012	
392	62.174	
393	62.337	
394	62.500	s 64
395	62.663	
396	62.826	
397	62.988	
398	63.151	
399	63.314	

word	512 bins	447	71.126	
		448	71.289	s 73
400	63.477	449	71.452	
401	63.639	450	71.615	
402	63.802	451	71.777	
403	63.965	452	71.940	
404	64.128	453	72.103	
405	64.290	454	72.266	s 74
406	64.453	455	72.428	
407	64.616	456	72.591	
408	64.779	457	72.754	
409	64.941	458	72.917	
410	65.104	459	73.079	
411	65.267	460	73.242	s 75
412	65.430	461	73.405	
413	65.592	462	73.568	
414	65.755	463	73.730	
415	65.918	464	73.893	
416	66.081	465	74.056	
417	66.243	466	74.219	s 76
418	66.406	467	74.382	
419	66.569	468	74.544	
420	66.732	469	74.707	
421	66.895	470	74.870	
422	67.057	471	75.033	
423	67.220	472	75.195	s 77
424	67.383	473	75.358	
425	67.546	474	75.521	
426	67.708	475	75.684	
427	67.871	476	75.846	
428	68.034	477	76.009	
429	68.197	478	76.172	s 78
430	68.359	479	76.335	
431	68.522	480	76.497	
432	68.685	481	76.660	
433	68.848	482	76.823	
434	69.010	483	76.986	
435	69.173	484	77.148	s 79
436	69.336	485	77.311	
437	69.499	486	77.474	
438	69.661	487	77.637	
439	69.824	488	77.799	
440	69.987	489	77.962	
441	70.150	490	78.125	s 80
442	70.312	491	78.288	
443	70.475	492	78.451	
444	70.638	493	78.613	
445	70.801	494	78.776	
446	70.964	495	78.939	
496	79.102	507	80.892	
497	79.264	508	81.055	s 83
498	79.427	509	81.217	
499	79.590	510	81.380	
500	79.753	511	81.543	
501	79.915			
502	80.078			s 82
503	80.241			
504	80.404			
505	80.566			
506	80.729			

IV Sounding Frequency Tables

IV-1 Sounding frequency (kHz) vs frequency step number N (synthesizer steps)

N	Frequency	N	Frequency	N	Frequency
0	0.	43	41.9922	86	83.9844
1	not 0.9766	44	42.9688	87	84.9609
2	used 1.9531	45	43.9453	88	85.9375
3	2.9297	46	44.9219	89	86.9141
4	3.9063	47	45.8984	90	87.8906
5	4.8828	48	46.8750	91	N 88.8672
6	5.8594	49	47.8516	92	89.8438
7	6.8359	50	48.8281	93	O 90.8203
8	7.8125	51	49.8047	94	91.7969
9	8.7891	52	50.7813	95	T 92.7734
10	9.7656	53	51.7578	96	93.7500
11	10.7422	54	52.7344	97	94.7266
12	11.7188	55	53.7109	98	95.7031
13	12.6953	56	54.6875	99	96.6797
14	13.6719	57	55.6641	100	97.6563
15	14.6484	58	56.6406	101	U 98.6328
16	15.6250	59	57.6172	102	99.6094
17	16.6016	60	58.5938	103	S 100.5859
18	17.5781	61	59.5703	104	101.5625
19	18.5547	62	60.5469	105	E 102.5391
20	19.5313	63	61.5234	106	103.5156
21	20.5078	64	62.5000	107	D 104.4922
22	21.4844	65	63.4766	108	105.4688
23	22.4609	66	64.4531	109	106.4453
24	23.4375	67	65.4297	110	107.4219
25	24.4141	68	66.4063	111	108.3984
26	25.3906	69	67.3828	112	109.3750
27	26.3672	70	68.3594	113	110.3516
28	27.3438	71	69.3359	114	111.3281
29	28.3203	72	70.3125	115	112.3047
30	29.2969	73	71.2891	116	113.2813
31	30.2734	74	72.2656	117	114.2578
32	31.2500	75	73.2422	118	115.2344
33	32.2266	76	74.2188	119	116.2109
34	33.2031	77	75.1953	120	117.1875
35	34.1797	78	76.1719	121	118.1641
36	35.1563	79	77.1484	122	119.1406
37	36.1328	80	78.1250	123	120.1172
38	37.1094	81	79.1016	124	121.0938
39	38.0859	82	80.0781	125	122.0703
40	39.0625	83	81.0547	126	123.0469
41	40.0391	84	82.0313	127	124.0234
42	41.0156	85	83.0078		

IV-2 Frequency Scan Tables (fst)

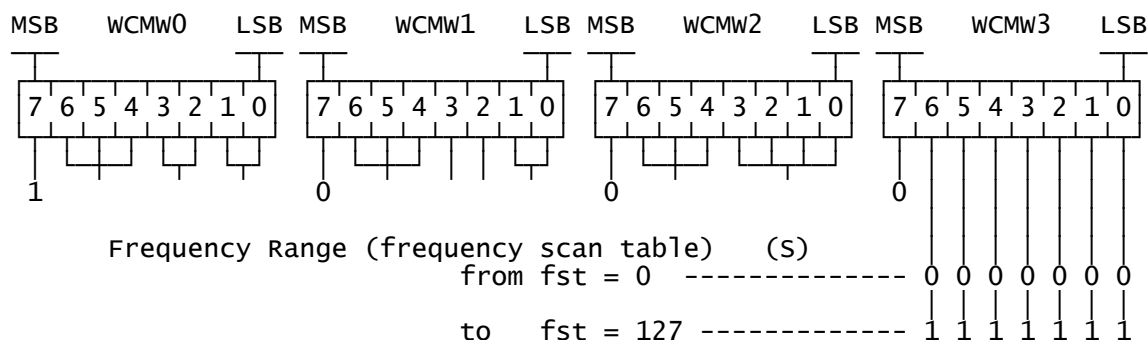

fst encoding

The bit 6,5,4 of fst define the top value of the synthesizer for a given table.

with a modulus of 8	fst = -----	x	x	x	x	x	x	x
starting from	N top = 27							
	N top = 35	0	0	0				
	N top = 43	0	0	1				
	N top = 51	0	1	0				
	N top = 59	0	1	1				
	N top = 67	1	0	0				
	N top = 75	1	0	1				
ending at	N top = 83	1	1	0				
		1	1	1				

The bit 3,2,1,0 of fst define the bottom value of the synthesizer for a given table.

with a modulus of 8	fst = -----	x	x	x	x	x	x	x
starting from	N bottom = 4							
increasing with a modulus of 1	N bottom = 8				0	0	0	0
up to	N bottom = 18				:	:	:	:
increasing with a modulus of 2	N bottom = 42				0	1	0	0
up to					:	:	:	:
increasing with a modulus of 4					1	0	0	1
up to					:	:	:	:
					1	1	1	1

The FST values giving a N top > or = N bottom + 10 are assigned to the fixed tables as shown in the FST table.

In the 0.512 ms duration mode, when it is found an even value for N bottom, N top is decremented of 1.

During the setup phase of WHISPER, the FST is decoded according to the above criteria. Then the sweep frequencies are calculated using an algorithm defined below. If the sweep corresponds to the criteria, the whole calculated table is placed in the external memory and the frequencies are scanned from this table during the sequence. If the FST value corresponds to a fixed table, the fixed table number is identified and the sweep is initialised at the beginning of the corresponding table and scanned from this table located in PROM memory as Constant.

Frequency Scan Tables (algorithm for standard tables)

Out of the 128 Frequency Tables (FST number running from 0 to 127), 90 are constructed via an algorithm, (standard tables) and 38 are fixed sequences of step numbers.

A step number N corresponds to a frequency: $f = N * f_0$

$$f_0 \text{ (kHz)} = \frac{500}{512} \quad (f_0 = 976.56 \text{ Hz})$$

In standard frequency tables, a top and a bottom N value, Ntop and Nbot are defined. The number of useful N values in this range depends of the pulse duration.

We define a modulus value, (our choice is -now- $m=6$) and a parameter j.

j = 1 for a pulse length $t_0 = (f_0) - 1 = 1.024\text{ms}$

j = 2 for a pulse length $t_0 = (2f_0) - 1 = 0.512\text{ms}$

The algorithm delivers an arrangement of the useful values of N located between Ntop and Nbot (included), made of m series of N values, according to:

Ntop, Ntop - 6*j, Ntop - 12*j, ...	stop and	exclude for N	>= Nbot + 10
Ntop - 2*j, Ntop - 8*j, ...	"	"	"
Ntop - 4*j, Ntop - 10*j, ...	"	"	"
Ntop - j, ... etc...	"	"	"
Ntop - 3*j,	"	"	"
Ntop - 5*j,	"	"	"

Below:

- A list of the FST values, with for each of them (except fixed table cases), Ntop, Nbot, and the total number of steps, this in the two cases of pulse length.
- The program to construct the above list.
- An example of the N sequence derived with the algorithm.

WHISPER frequency scan table "fst"

Algo or Fixed table 1.024ms (PULSE = 0) / 0.512 (PULSE = 1)

fst		Top synthe	Bottom synthe	steps numb	decrement	
0	00h	A	27/26	4	24/12	6
1	01h	A	27	5	23/12	6
2	02h	A	27/26	6	22/11	6
3	03h	A	27	7	21/11	6
4	04h	A	27/26	8	20/10	6
5	05h	A	27/26	10	18/9	6
6	06h	A	27/26	12	16/8	6
7	07h	A	27/26	14	14/7	6
8	08h	A	27/26	16	12/6	6
9	09h	A	27/26	18	10/5	6
10	0Ah	A	27/26	22	6/3	2
11	0Bh	F 0	83	4	80	1 1.024ms
12	0Ch	F 1	82	4	40	2 0.512ms
13	0Dh	F 2	43	4	40	1 1.024ms
14	0Eh	F 3	82	4	52	12 mixed
15	0Fh	F 4	82	4	58	12 mixed
16	10h	A	35/34	4	32/16	6
17	11h	A	35	5	31/16	6
18	12h	A	35/34	6	30/15	6
19	13h	A	35	7	29/15	6
20	14h	A	35/34	8	28/14	6
21	15h	A	35/34	10	26/13	6
22	16h	A	35/34	12	24/12	6
23	17h	A	35/34	14	22/11	6
24	18h	A	35/34	16	20/10	6
25	19h	A	35/34	18	18/9	6
26	1Ah	A	35/34	22	14/7	6
27	1Bh	A	35/34	26	10/5	6
28	1Ch	A	35/34	30	6/3	2
29	1Dh	F 5	66	4	40	12 mixed
30	1Eh	F 6	36	4	32	12 mixed
31	1Fh	F 7	68	6	40	12 mixed
32	20h	A	43/42	4	40/20	6
33	21h	A	43	5	39/20	6
34	22h	A	43/42	6	38/19	6
35	23h	A	43	7	37/19	6
36	24h	A	43/42	8	36/18	6
37	25h	A	43/42	10	34/17	6
38	26h	A	43/42	12	32/16	6
39	27h	A	43/42	14	30/15	6
40	28h	A	43/42	16	28/14	6
41	29h	A	43/42	18	26/13	6
42	2Ah	A	43/42	22	22/11	6
43	2Bh	A	43	26	18/9	6
44	2Ch	A	43/42	30	14/7	6
45	2Dh	A	43/42	34	10/5	6
46	2Eh	A	43/42	38	6/3	2
47	2Fh	F 8	62	6	36	12 mixed
48	30h	A	51/50	4	48/24	6

Algo or Fixed table 1.024ms (PULSE = 0) / 0.512 (PULSE = 1)

fst		Top synthe	Bottom synthe	steps numb	decrement
49	31h	A 51	5	47/24	6
50	32h	A 51/50	6	46/23	6
51	33h	A 51	7	45/23	6
52	34h	A 51/50	8	44/22	6
53	35h	A 51/50	10	42/21	6
54	36h	A 51/50	12	40/20	6
55	37h	A 51/50	14	38/19	6
56	38h	A 51/50	16	36/18	6
57	39h	A 51/50	18	34/17	6
58	3Ah	F 9 75	5	40	8/4 mixed
59	3Bh	F 10 79	5	38	4 0.512ms
60	3Ch	F 11 75	5	36	4 0.512ms
61	3Dh	F 12 71	5	34	4 0.512ms
62	3Eh	F 13 67	5	32	4 0.512ms
63	3Fh	A 51/50	42	10/5	6
64	40h	A 59/58	4	56/28	6
65	41h	A 59	5	55/28	6
66	42h	A 59/58	6	54/27	6
67	43h	A 59	7	53/27	6
68	44h	A 59/58	8	52/26	6
69	45h	A 59/58	10	50/25	6
70	46h	A 59/58	12	48/24	6
71	47h	F 14 81	5	39	6 0.512ms
72	48h	F 15 79	5	38	6 0.512ms
73	49h	F 16 77	5	37	6 0.512ms
74	4Ah	F 17 73	5	35	6 0.512ms
75	4Bh	F 18 71	5	34	6 0.512ms
76	4Ch	F 19 69	5	33	6 0.512ms
77	4Dh	F 20 45	5	21	4 0.512ms
78	4Eh	F 21 49	5	46	4 1.024ms
79	4Fh	A 59/58	42	18/9	6
80	50h	A 67/66	4	64/32	6
81	51h	A 67	5	63/32	6
82	52h	A 67/66	6	62/31	6
83	53h	A 67	7	61/31	6
84	54h	A 67/66	8	60/30	6
85	55h	A 67/66	10	58/29	6
86	56h	A 67/66	12	56/28	6
87	57h	A 67/66	14	54/27	6
88	58h	A 67/66	16	52/26	6
89	59h	A 67/66	18	50/25	6
90	5Ah	A 67/66	22	46/23	6
91	5Bh	A 67/66	26	42/21	6
92	5Ch	F 22 79	4	46	8/4 mixed
93	5Dh	F 23 81	4	59	4 mixed
94	5Eh	F 24 51	4	34	4 mixed
95	5Fh	A 67/66	42	26/13	6
96	60h	A 75/74	4	72/36	6
97	61h	A 75	5	71/36	6
98	62h	A 75/74	6	70/35	6
99	63h	A 75	7	69/35	6
100	64h	A 75/74	8	68/34	6
101	65h	A 75/74	10	66/33	6
102	66h	A 75/74	12	64/32	6

Algo or Fixed table 1.024ms (PULSE = 0) / 0.512 (PULSE = 1)

fst		Top synthe	Bottom synthe	steps numb	decrement	
103	67h	F 25	83	4	80	4 1.024ms
104	68h	F 26	81	4	78	4 1.024ms
105	69h	F 27	79	4	76	4 1.024ms
106	6Ah	F 28	77	4	74	4 1.024ms
107	6Bh	F 29	75	4	72	4 1.024ms
108	6Ch	F 30	83	4	80	2 1.024ms
109	6Dh	F 31	79	4	76	2 1.024ms
110	6Eh	F 32	75	4	72	2 1.024ms
111	6Fh	F 33	71	4	68	2 1.024ms
112	70h	A	83/82	4	80/40	6
113	71h	A	83	5	79/40	6
114	72h	A	83/82	6	78/39	6
115	73h	A	83	7	77/39	6
116	74h	A	83/82	8	76/38	6
117	75h	A	83/82	10	74/37	6
118	76h	A	83/82	12	72/36	6
119	77h	F 34	82	4	79	6 1.024ms
120	78h	F 35	80	4	77	6 1.024ms
121	79h	F 36	78	4	75	6 1.024ms
122	7Ah	F 37	76	4	73	6 1.024ms
123	7Bh	F 38	74	4	71	6 1.024ms
124	7Ch	F 39	72	4	69	6 1.024ms
125	7Dh	F 40	70	4	67	6 1.024ms
126	7Eh	F 41	68	4	65	6 1.024ms
127	7Fh	F 42	66	4	63	6 1.024ms

Frequency Scan Tables fixed tables (special sweeps)

Here figure a few tables which cannot be constructed with the above algorithm. The program used to construct those tables, and a complete description of the actual sequence of sounding frequencies is attached.

The pulse duration value is actually defined at each step of the table. The 'pulse' parameter attached to the WCMW has a totally different signification. This bit is devoted to the 'delay' parameter (see Section II 1, Pulse duration definition).

i) Fixed tables #0 to 2

Simple decreasing sequences of N numbers, constant value of pulse duration bit (bitvalue = 0 for 1ms; bit value=1 for 0.5ms).

ii) Fixed tables #3 to 9 and 22 to 24

The idea is to cut a sweep in two frequency bands, trigger the plasma with short duration pulses in the high frequency part of the sweep, where the resonances are known to be the strongest, and with long duration pulses in the low frequency part of the sweep. The corresponding sweep duration can thus be optimized within the power constraints. Among those tables, # 5, 7 and 9 (40 steps) can be used in Gliding mode.

Note : The gain in time resolution is about a factor 2. In the example shown in Table #3, if we want to operate at high emission level and stay within the nominal power, we need 3.2s (80 steps of 40ms) for a full sweep with long pulses. For a mixed sweep (Table #3), we satisfy the power constraint with steps of 26.66ms: it is in the high frequency range, where the consumption is high, that we use the less consuming short pulses. In addition, the total number of steps is reduced (to 52 in the example) which yields a total duration of about 1.5s. During continuous soundings, this gain in time resolution can be taken fully advantage of mainly with high TM rates, which can transmit the necessary information. In alternate active/passive Whisper operations, this sweep permits to shorten any possible disturbance of the sounder to its environment.

iii) Fixed tables # 10 to 21 and 25 to 42

They present various characteristics (frequency range, step number and step duration). Fixed tables are here replacing algorithmic tables of weak interest (frequency range limited to the upper range).

Format of the fixed frequency table

Format of the fixed frequency tables :

The first byte shows the number of the frequency steps. The following bytes are the elements of the frequency (the synthesizer step number). Some frequency steps are attached to a short pulse duration (0.512ms) for these frequency steps the MSB is set to 1 (the step number is : step_num + 128).

Each table ends with a 0 value.

NOTE : Whatever PULSE position (1 or 0) the duration is defined in the fix table; In DWP processed modes, if PULSE is set to 1 in cases 1E3R, 1E5R, 1E8R and SYNC, the first acquisition after Blanking Pulse is delayed of 13.33 ms (see Note p.12).

```
/* FIXED FREQUENCY TABLES */
```

```
/* Located in PROM memory at address */
```

```
/* given in *tab_ptr */
```

```
/* fixed table number 0 (fst 11): all from 83 to 4 */
```

```
/* 80 steps with PULSE 0 or 1 */
```

```
const unsigned char fix_table_0 [] = { 80,  
83, 82, 81, 80, 79, 78, 77, 76, 75, 74, 73, 72,  
71, 70, 69, 68, 67, 66, 65, 64, 63, 62, 61, 60,  
59, 58, 57, 56, 55, 54, 53, 52, 51, 50, 49, 48,  
47, 46, 45, 44, 43, 42, 41, 40, 39, 38, 37, 36,  
35, 34, 33, 32, 31, 30, 29, 28, 27, 26, 25, 24,  
23, 22, 21, 20, 19, 18, 17, 16, 15, 14, 13, 12,  
11, 10, 9, 8, 7, 6, 5, 4, 0, };
```

```
/* fixed table number 1 (fst 12): even steps from 82 to 4 */
```

```
/* 40 steps 0.512ms */
```

```
const unsigned char fix_table_1 [] = { 40,  
210,208,206,204,202,200,198,196,194,192,190,188,  
186,184,182,180,178,176,174,172,170,168,166,164,  
162,160,158,156,154,152,150,148,146,144,142,140,  
138,136,134,132, 0, };
```

```
/* fixed table number 2 (fst 13): low frequency 43 to 4 */
```

```
/* 40 steps with PULSE 0 or 1 */
```

```
const unsigned char fix_table_2 [] = { 40,  
43, 42, 41, 40, 39, 38, 37, 36, 35, 34, 33, 32,  
31, 30, 29, 28, 27, 26, 25, 24, 23, 22, 21, 20,  
19, 18, 17, 16, 15, 14, 13, 12, 11, 10, 9, 8,  
7, 6, 5, 4, 0, };
```

```
/* fixed table number 3 (fst 14): mixed */
```

```
/* 28 steps 0.512ms */
```

```
/* 24 steps 1.024ms */
```

```
const unsigned char fix_table_3 [] = { 52,  
210,198,186,174,162,206,194,182,170,158,202,190,  
178,166,208,196,184,172,160,204,192,180,168,156,  
200,188,176,164, 27, 21, 15, 9, 25, 19, 13, 7,  
23, 17, 11, 5, 26, 20, 14, 8, 24, 18, 12, 6,  
22, 16, 10, 4, 0, };
```

```
/* fixed table number 4 (fst 15): mixed */
```

```
/* 22 steps 0.512ms */
```

```
/* 36 steps 1.024ms */
```

```
const unsigned char fix_table_4 [] = { 58,  
210,198,186,174,206,194,182,170,202,190,178,208,  
196,184,172,204,192,180,168,200,188,176, 39, 33,  
27, 21, 15, 9, 37, 31, 25, 19, 13, 7, 35, 29,  
23, 17, 11, 5, 38, 32, 26, 20, 14, 8, 36, 30,  
24, 18, 12, 6, 34, 28, 22, 16, 10, 4, 0, };
```

```
/* fixed table number 5 (fst 29): mixed GLIDING mode */
```

```
/* 24 steps 0.512ms */
```

```
/* 16 steps 1.024ms */
```

```

const unsigned char fix_table_5 [] = { 40,
190,178,166,154,186,174,162,150,194,182,170,158,
188,176,164,152,184,172,160,148,192,180,168,156,
19, 13, 7, 17, 11, 5, 15, 9, 18, 12, 6, 16,
10, 4, 14, 8, 0, };

/* fixed table number 6 (fst 30): mixed mode */
/* 12 steps 0.512ms */
/* 20steps 1.024ms */
const unsigned char fix_table_6 [] = { 32,
164,152,168,156,172,160,166,154,170,158,174,162,
23, 17, 11, 5, 21, 15, 9, 19, 13, 7, 22, 16,
10, 4, 20, 14, 8, 18, 12, 6, 0, };

/* fixed table number 7 (fst 31): mixed GLIDING mode */
/* with no resonance in STAFF range */
/* 22 steps 0.512ms */
/* 18 steps 1.024ms */
const unsigned char fix_table_7 [] = { 40,
188,176,164,152,192,180,168,156,196,184,172,160,
190,178,166,154,182,170,158,186,174,162, 23, 17,
11, 21, 15, 9, 19, 13, 7, 22, 16, 10, 20, 14,
8, 18, 12, 6, 0, };

/* fixed table number 8 (fst 47): mixed STAFF adapted */
/* 22 steps 0.512ms */
/* 14 steps 1.024ms */
const unsigned char fix_table_8 [] = { 36,
190,178,166,154,186,174,162,150,182,170,158,188,
176,164,152,146,184,172,160,148,180,168,156, 13,
7, 17, 11, 5, 15, 9, 12, 6, 16, 10, 14, 8,
0 };

/* fixed table number 9 (fst 58): 75 to 5 mixed */
/* 33 steps 0.512ms */
/* 7 steps 1.024ms */
const unsigned char fix_table_9 [] = { 40,
203,195,187,179,171,163,155,147,139, 7,201,193,
185,177,169,161,153,145, 10, 6,199,191,183,175,
167,159,151,143, 9, 5,197,189,181,173,165,157,
149,141, 8, 4, 0 };

/* fixed table number 10 (fst 59): 79 to 5 (decr. 4) */
/* 38 steps 0.512ms */
const unsigned char fix_table_10 [] = { 38,
207,203,199,195,191,187,183,179,175,171,167,163,
159,155,151,147,143,139,135,205,201,197,193,189,
185,181,177,173,169,165,161,157,153,149,145,141,
137,133, 0 };

```

```
/* fixed table number 11 (fst 60): 75 to 5 (decr. 4) */
/* 36 steps 0.512ms */
const unsigned char fix_table_11 [] = { 36,
203,199,195,191,187,183,179,175,171,167,163,159,
155,151,147,143,139,135,201,197,193,189,185,181,
177,173,169,165,161,157,153,149,145,141,137,133,
0 };
```

```
/* fixed table number 12 (fst 61): 71 to 5 (decr. 4) */
/* 34 steps 0.512ms */
const unsigned char fix_table_12 [] = { 34,
199,195,191,187,183,179,175,171,167,163,159,155,
151,147,143,139,135,197,193,189,185,181,177,173,
169,165,161,157,153,149,145,141,137,133, 0 };
```

```
/* fixed table number 13 (fst 62): 67 to 5 (decr. 4) */
/* 32 steps 0.512 */
const unsigned char fix_table_13 [] = { 32,
195,191,187,183,179,175,171,167,163,159,155,151,
147,143,139,135,193,189,185,181,177,173,169,165,
161,157,153,149,145,141,137,133, 0 };
```

```
/* fixed table number 14 (fst 71): 81 to 5 (decr. 6) */
/* 39 steps 0.512ms */
const unsigned char fix_table_14 [] = { 39,
209,203,197,191,185,179,173,167,161,155,149,143,
137,207,201,195,189,183,177,171,165,159,153,147,
141,135,205,199,193,187,181,175,169,163,157,151,
145,139,133, 0 };
```

```
/* fixed table number 15 (fst 72): 79 to 5 (decr. 6) */
/* 38 steps 0.512ms */
const unsigned char fix_table_15 [] = { 38,
207,201,195,189,183,177,171,165,159,153,147,141,
135,205,199,193,187,181,175,169,163,157,151,145,
139,133,203,197,191,185,179,173,167,161,155,149,
143,137, 0 };
```

```
/* fixed table number 16 (fst 73): 77 to 5 (decr. 6) */
/* 37 steps 0.512ms */
const unsigned char fix_table_16 [] = { 37,
205,199,193,187,181,175,169,163,157,151,145,139,
133,203,197,191,185,179,173,167,161,155,149,143,
137,201,195,189,183,177,171,165,159,153,147,141,
135, 0 };
```

```
/* fixed table number 17 (fst 74): 73 to 5 (decr. 6) */
/* 35 steps 0.512ms */
const unsigned char fix_table_17 [] = { 35,
201,195,189,183,177,171,165,159,153,147,141,135,
199,193,187,181,175,169,163,157,151,145,139,133,
197,191,185,179,173,167,161,155,149,143,137, 0 };
```

```
/* fixed table number 18 (fst 75): 71 to 5 (decr. 6) */
/* 34 steps 0.512ms */
const unsigned char fix_table_18 [] = { 34,
199,193,187,181,175,169,163,157,151,145,139,133,
197,191,185,179,173,167,161,155,149,143,137,195,
189,183,177,171,165,159,153,147,141,135, 0 };
```

```

/* fixed table number 19 (fst 76): 69 to 5 (decr. 6) */
/* 33 steps 0.512ms */
const unsigned char fix_table_19 [] = { 33,
197,191,185,179,173,167,161,155,149,143,137,195,
189,183,177,171,165,159,153,147,141,135,193,187,
181,175,169,163,157,151,145,139,133, 0 };

/* fixed table number 20 (fst 77): 47 to 5 (decr. 4) */
/* 21 steps 0.512ms */
const unsigned char fix_table_20 [] = { 21,
173,169,165,161,157,153,149,145,141,137,133,171,
167,163,159,155,151,147,143,139,135 };

/* fixed table number 21 (fst 78): 49 to 5 (decr. 4) */
/* 46 steps 1.024ms */
const unsigned char fix_table_21 [] = { 46,
49, 45, 41, 37, 33, 29, 25, 21, 17, 13, 9, 5,
48, 44, 40, 36, 32, 28, 24, 20, 16, 12, 8, 4,
47, 43, 39, 35, 31, 27, 23, 19, 15, 11, 7,
46, 42, 38, 34, 30, 26, 22, 18, 14, 10, 6, 0 };

/* fixed table number 22 (fst 92): mixed (decr. 8/4) */
/* 31 steps 0.512ms */
/* 15 steps 1.024ms */
const unsigned char fix_table_22 [] = { 46,
207,199,191,183,175,167,159,151,205,197,189,181,
173,165,157,149,203,195,187,179,171,163,155,147,
201,193,185,177,169,161,153, 17, 13, 9, 5, 15,
11, 7, 18, 14, 10, 6, 16, 12, 8, 4, 0 };

/* fixed table number 23 (fst 93): mixed (decr. 4) */
/* 20 steps 0.512ms */
/* 39 steps 1.024ms */
const unsigned char fix_table_23 [] = { 59,
209,205,201,197,193,189,185,181,177,173,207,203,
199,195,191,187,183,179,175,171, 39, 35, 31, 27,
23, 19, 15, 11, 7, 41, 37, 33, 29, 25, 21, 17,
13, 9, 5, 42, 38, 34, 30, 26, 22, 18, 14, 10,
6, 40, 36, 32, 28, 24, 20, 16, 12, 8, 4, 0 };

/* fixed table number 24 (fst 94): mixed (decr. 4) */
/* 15 steps 0.512ms */
/* 19 steps 1.024ms */
const unsigned char fix_table_24 [] = { 34,
179,175,171,167,163,159,155,151,177,173,169,165,
161,157,153, 21, 17, 13, 9, 5, 19, 15, 11, 7,
22, 18, 14, 10, 6, 20, 16, 12, 8, 4, 0 };

/* fixed table number 25 (fst 103): 83 to 4 (decr. 4) */
/* 80 steps with PULSE 0 or 1 */
const unsigned char fix_table_25 [] = { 80,
83, 79, 75, 71, 67, 63, 59, 55, 51, 47, 43, 39,
35, 31, 27, 23, 19, 15, 11, 7, 81, 77, 73, 69,
65, 61, 57, 53, 49, 45, 41, 37, 33, 29, 25, 21,
17, 13, 9, 5, 82, 78, 74, 70, 66, 62, 58, 54,
50, 46, 42, 38, 34, 30, 26, 22, 18, 14, 10, 6,
80, 76, 72, 68, 64, 60, 56, 52, 48, 44, 40, 36,
32, 28, 24, 20, 16, 12, 8, 4, 0 };

/* fixed table number 26 (fst 104): 81 to 4 (decr. 4) */
/* 78 steps with PULSE 0 or 1 */

```

```
const unsigned char fix_table_26 [] = { 78,
81, 77, 73, 69, 65, 61, 57, 53, 49, 45, 41, 37,
33, 29, 25, 21, 17, 13, 9, 5, 79, 75, 71, 67,
63, 59, 55, 51, 47, 43, 39, 35, 31, 27, 23, 19,
15, 11, 7, 80, 76, 72, 68, 64, 60, 56, 52, 48,
44, 40, 36, 32, 28, 24, 20, 16, 12, 8, 4, 78,
74, 70, 66, 62, 58, 54, 50, 46, 42, 38, 34, 30,
26, 22, 18, 14, 10, 6, 0 };
```

```
/* fixed table number 27 (fst 105): 79 to 4 (decr. 4) */
```

```
/* 76 steps with PULSE 0 or 1 */
```

```
const unsigned char fix_table_27 [] = { 76,
79, 75, 71, 67, 63, 59, 55, 51, 47, 43, 39, 35,
31, 27, 23, 19, 15, 11, 7, 77, 73, 69, 65, 61,
57, 53, 49, 45, 41, 37, 33, 29, 25, 21, 17, 13,
9, 5, 78, 74, 70, 66, 62, 58, 54, 50, 46, 42,
38, 34, 30, 26, 22, 18, 14, 10, 6, 76, 72, 68,
64, 60, 56, 52, 48, 44, 40, 36, 32, 28, 24, 20,
16, 12, 8, 4, 0 };
```

```
/* fixed table number 28 (fst 106): 77 to 4 (decr. 4) */
```

```
/* 74 steps with PULSE 0 or 1 */
```

```
const unsigned char fix_table_28 [] = { 74,
77, 73, 69, 65, 61, 57, 53, 49, 45, 41, 37, 33,
29, 25, 21, 17, 13, 9, 5, 75, 71, 67, 63, 59,
55, 51, 47, 43, 39, 35, 31, 27, 23, 19, 15, 11,
7, 76, 72, 68, 64, 60, 56, 52, 48, 44, 40, 36,
32, 28, 24, 20, 16, 12, 8, 4, 74, 70, 66, 62,
58, 54, 50, 46, 42, 38, 34, 30, 26, 22, 18, 14,
10, 6, 0 };
```

```
/* fixed table number 29 (fst 107): 75 to 4 (decr. 4) */
```

```
/* 72 steps with PULSE 0 or 1 */
```

```
const unsigned char fix_table_29 [] = { 72,
75, 71, 67, 63, 59, 55, 51, 47, 43, 39, 35, 31,
27, 23, 19, 15, 11, 7, 73, 69, 65, 61, 57, 53,
49, 45, 41, 37, 33, 29, 25, 21, 17, 13, 9, 5,
74, 70, 66, 62, 58, 54, 50, 46, 42, 38, 34, 30,
26, 22, 18, 14, 10, 6, 72, 68, 64, 60, 56, 52,
48, 44, 40, 36, 32, 28, 24, 20, 16, 12, 8, 4,
0 };
```

```
/* fixed table number 30 (fst 108): 83 to 4 (decr. 2) */
```

```
/* 80 steps with PULSE 0 or 1 */
```

```
const unsigned char fix_table_30 [] = { 80,
83, 81, 79, 77, 75, 73, 71, 69, 67, 65, 63, 61,
59, 57, 55, 53, 51, 49, 47, 45, 43, 41, 39, 37,
35, 33, 31, 29, 27, 25, 23, 21, 19, 17, 15, 13,
11, 9, 7, 5, 82, 80, 78, 76, 74, 72, 70, 68,
66, 64, 62, 60, 58, 56, 54, 52, 50, 48, 46, 44,
42, 40, 38, 36, 34, 32, 30, 28, 26, 24, 22, 20,
18, 16, 14, 12, 10, 8, 6, 4, 0 };
```

```
/* fixed table number 31 (fst 109): 79 to 4 (decr. 2) */
```

```
/* 76 steps with PULSE 0 or 1 */
```

```
const unsigned char fix_table_31 [] = { 76,
79, 77, 75, 73, 71, 69, 67, 65, 63, 61, 59, 57,
55, 53, 51, 49, 47, 45, 43, 41, 39, 37, 35, 33,
31, 29, 27, 25, 23, 21, 19, 17, 15, 13, 11, 9,
7, 5, 78, 76, 74, 72, 70, 68, 66, 64, 62, 60,
58, 56, 54, 52, 50, 48, 46, 44, 42, 40, 38, 36,
34, 32, 30, 28, 26, 24, 22, 20, 18, 16, 14, 12,
10, 8, 6, 4, 0 };
```

```
/* fixed table number 32 (fst 110): 75 to 4 (decr. 2) */
/* 72 steps with PULSE 0 or 1 */
const unsigned char fix_table_32 [] = { 72,
    75, 73, 71, 69, 67, 65, 63, 61, 59, 57, 55, 53,
    51, 49, 47, 45, 43, 41, 39, 37, 35, 33, 31, 29,
    27, 25, 23, 21, 19, 17, 15, 13, 11, 9, 7, 5,
    74, 72, 70, 68, 66, 64, 62, 60, 58, 56, 54, 52,
    50, 48, 46, 44, 42, 40, 38, 36, 34, 32, 30, 28,
    26, 24, 22, 20, 18, 16, 14, 12, 10, 8, 6, 4,
    0 };
```

```
/* fixed table number 33 (fst 111): 71 to 4 (decr. 2) */
/* 68 steps with PULSE 0 or 1 */
const unsigned char fix_table_33 [] = { 68,
    71, 69, 67, 65, 63, 61, 59, 57, 55, 53, 51, 49,
    47, 45, 43, 41, 39, 37, 35, 33, 31, 29, 27, 25,
    23, 21, 19, 17, 15, 13, 11, 9, 7, 5, 70, 68,
    66, 64, 62, 60, 58, 56, 54, 52, 50, 48, 46, 44,
    42, 40, 38, 36, 34, 32, 30, 28, 26, 24, 22, 20,
    18, 16, 14, 12, 10, 8, 6, 4, 0 };
```

```
/* fixed table number 34 (fst 119): 82 to 4 (decr. 6) */
/* 79 steps with PULSE 0 or 1 */
const unsigned char fix_table_34 [] = { 79,
    82, 76, 70, 64, 58, 52, 46, 40, 34, 28, 22, 16,
    10, 4, 80, 74, 68, 62, 56, 50, 44, 38, 32, 26,
    20, 14, 8, 78, 72, 66, 60, 54, 48, 42, 36, 30,
    24, 18, 12, 6, 81, 75, 69, 63, 57, 51, 45, 39,
    33, 27, 21, 15, 9, 79, 73, 67, 61, 55, 49, 43,
    37, 31, 25, 19, 13, 7, 77, 71, 65, 59, 53, 47,
    41, 35, 29, 23, 17, 11, 5, 0 };
```

```
/* fixed table number 35 (fst 120): 80 to 4 (decr. 6) */
/* 77 steps with PULSE 0 or 1 */
const unsigned char fix_table_35 [] = { 77,
    80, 74, 68, 62, 56, 50, 44, 38, 32, 26, 20, 14,
    8, 78, 72, 66, 60, 54, 48, 42, 36, 30, 24, 18,
    12, 6, 76, 70, 64, 58, 52, 46, 40, 34, 28, 22,
    16, 10, 4, 79, 73, 67, 61, 55, 49, 43, 37, 31,
    25, 19, 13, 7, 77, 71, 65, 59, 53, 47, 41, 35,
    29, 23, 17, 11, 5, 75, 69, 63, 57, 51, 45, 39,
    33, 27, 21, 15, 9, 0 };
```

```
/* fixed table number 36 (fst 121): 78 to 4 (decr. 6) */
/* 75 steps with PULSE 0 or 1 */
const unsigned char fix_table_36 [] = { 75,
    78, 72, 66, 60, 54, 48, 42, 36, 30, 24, 18, 12,
    6, 76, 70, 64, 58, 52, 46, 40, 34, 28, 22, 16,
    10, 4, 74, 68, 62, 56, 50, 44, 38, 32, 26, 20,
    14, 8, 77, 71, 65, 59, 53, 47, 41, 35, 29, 23,
    17, 11, 5, 75, 69, 63, 57, 51, 45, 39, 33, 27,
    21, 15, 9, 73, 67, 61, 55, 49, 43, 37, 31, 25,
    19, 13, 7, 0 };
```

```
/* fixed table number 37 (fst 122): 76 to 4 (decr. 6) */
/* 73 steps with PULSE 0 or 1 */
const unsigned char fix_table_37 [] = { 73,
    76, 70, 64, 58, 52, 46, 40, 34, 28, 22, 16, 10,
    4, 74, 68, 62, 56, 50, 44, 38, 32, 26, 20, 14,
    8, 72, 66, 60, 54, 48, 42, 36, 30, 24, 18, 12,
    6, 75, 69, 63, 57, 51, 45, 39, 33, 27, 21, 15,
```

```
9, 73, 67, 61, 55, 49, 43, 37, 31, 25, 19, 13,  
7, 71, 65, 59, 53, 47, 41, 35, 29, 23, 17, 11,  
5, 0 };
```

```
/* fixed table number 38 (fst 123): 74 to 4 (decr. 6) */
```

```
/* 71 steps with PULSE 0 or 1 */
```

```
const unsigned char fix_table_38 [] = { 71,  
74, 68, 62, 56, 50, 44, 38, 32, 26, 20, 14, 8,  
72, 66, 60, 54, 48, 42, 36, 30, 24, 18, 12, 6,  
70, 64, 58, 52, 46, 40, 34, 28, 22, 16, 10, 4,  
73, 67, 61, 55, 49, 43, 37, 31, 25, 19, 13, 7,  
71, 65, 59, 53, 47, 41, 35, 29, 23, 17, 11, 5,  
69, 63, 57, 51, 45, 39, 33, 27, 21, 15, 9, 0 };
```

```
/* fixed table number 39 (fst 124): 72 to 4 (decr. 6) */
```

```
/* 69 steps with PULSE 0 or 1 */
```

```
const unsigned char fix_table_39 [] = { 69,  
72, 66, 60, 54, 48, 42, 36, 30, 24, 18, 12, 6,  
70, 64, 58, 52, 46, 40, 34, 28, 22, 16, 10, 4,  
68, 62, 56, 50, 44, 38, 32, 26, 20, 14, 8, 71,  
65, 59, 53, 47, 41, 35, 29, 23, 17, 11, 5, 69,  
63, 57, 51, 45, 39, 33, 27, 21, 15, 9, 67, 61,  
55, 49, 43, 37, 31, 25, 19, 13, 7, 0 };
```

```
/* fixed table number 40 (fst 125): 70 to 4 (decr. 6) */
```

```
/* 67 steps with PULSE 0 or 1 */
```

```
const unsigned char fix_table_40 [] = { 67,  
70, 64, 58, 52, 46, 40, 34, 28, 22, 16, 10, 4,  
68, 62, 56, 50, 44, 38, 32, 26, 20, 14, 8, 66,  
60, 54, 48, 42, 36, 30, 24, 18, 12, 6, 69, 63,  
57, 51, 45, 39, 33, 27, 21, 15, 9, 67, 61, 55,  
49, 43, 37, 31, 25, 19, 13, 7, 65, 59, 53, 47,  
41, 35, 29, 23, 17, 11, 5, 0 };
```

```
/* fixed table number 41 (fst 126): 68 to 4 (decr. 6) */
/* 65 steps with PULSE 0 or 1 */
const unsigned char fix_table_41 [] = { 65,
68, 62, 56, 50, 44, 38, 32, 26, 20, 14, 8, 66,
60, 54, 48, 42, 36, 30, 24, 18, 12, 6, 64, 58,
52, 46, 40, 34, 28, 22, 16, 10, 4, 67, 61, 55,
49, 43, 37, 31, 25, 19, 13, 7, 65, 59, 53, 47,
41, 35, 29, 23, 17, 11, 5, 63, 57, 51, 45, 39,
33, 27, 21, 15, 9, 0 };
```

```
/* fixed table number 42 (fst 127): 66 to 4 (decr. 6) */
/* 63 steps with PULSE 0 or 1 */
const unsigned char fix_table_42 [] = { 63,
66, 60, 54, 48, 42, 36, 30, 24, 18, 12, 6, 64,
58, 52, 46, 40, 34, 28, 22, 16, 10, 4, 62, 56,
50, 44, 38, 32, 26, 20, 14, 8, 65, 59, 53, 47,
41, 35, 29, 23, 17, 11, 5, 63, 57, 51, 45, 39,
33, 27, 21, 15, 9, 61, 55, 49, 43, 37, 31, 25,
19, 13, 7, 0 };
```

Frequency Scan Tables fixed tables (calibrations)

For special operations, like calibration, frequency tables are constructed via series of N values given term by term.

```
/* CALIBRATION TABLE */
```

```
const unsigned char tab_cal [] = {  
124, 100, 76, 72, 64, 52, 36, 20, 16, 8, 0,  
76, 72, 64, 52, 44, 36, 24, 16, 12, 8, 0,  
76, 16, 0 };
```

Note : The N values correspond to the synthesiser step.

The values 124 and 100 which are out of the normal frequency range, are used in the Calibration 1 (Quiet) in order to verify the cut-off frequency of the filter.

The first values from 124 to 0 (12 steps) are dedicated to the calibration 1 (Quiet).

The remaining values from 76 to 0 (12 steps) are dedicated to the calibration 2 (Sounding).

For both calibrations the transmitter operate for a duration of 1.024 ms, the receiver is sampling during the same period. All the transmitting levels and all the gain switches are used for every frequency step. The sampled data are analysed with an fft size of 64 bins.

Frequency Swept Operations(sounding)

The frequency swept operations are conducted according to four elements of the Whisper command words : Rep_fac, smode_aver, fst (and level).

Rep_fac defines the total number of sweeps controlled by the command.

Fst defines the frequency table, which in turn defines the central frequencies and duration of each transmitted pulse - a sine wave train - in a series of n pulses forming the sweep.

Smode_aver defines the Emission/Reception rate, i.e. the time between two successive transmissions. Here the control is taken by DWP, which delivers the BLANKING PULSE signal (see section II 1) to Whisper at the constant rate defined by smode_aver, as long as the Rep_fac and n series are running.

Whisper constructs the sine wave train according to fst (and level), and transmits them using the Blanking pulse as trigger. In case of DWP post processing, Whisper suspends the transmissions at the end of each sweep, in order to give to DWP the required calculation time - at least 50 ms - at this stage. The latency time between two successive sweeps is equal to an integer number of frequency steps, as follows :

- 4 steps for 1E1R (53.3 ms),
- 2 steps for 1E2R (53.3 ms) and 1E3R (80ms),
- 1 step for 1E5R (76.6 ms) and 1E8R (106.6 ms).

No latency time is needed for the Gliding and Sync modes.

The shown number are the synthesiser (syn_step) decimal value followed by the calculated duration of the pulse (pulse_cal) (0 = 1.024ms, 1 = 0.512ms).

mode 2 = sounding

fst = 0 Algorithm table : 24 Steps PULSE (WCMW) = 0

27 0	21 0	15 0	9 0	25 0	19 0	13 0	7 0
23 0	17 0	11 0	5 0	26 0	20 0	14 0	8 0
24 0	18 0	12 0	6 0	22 0	16 0	10 0	4 0

fst = 0 Algorithm table : 12 Steps PULSE (WCMW) = 1

26 1	20 1	14 1	8 1	24 1	18 1	12 1	6 1
22 1	16 1	10 1	4 1				

fst = 1 Algorithm table : 23 Steps PULSE (WCMW) = 0

27 0	21 0	15 0	9 0	25 0	19 0	13 0	7 0
23 0	17 0	11 0	5 0	26 0	20 0	14 0	8 0
24 0	18 0	12 0	6 0	22 0	16 0	10 0	

fst = 1 Algorithm table : 12 Steps PULSE (WCMW) = 1

27 1	21 1	15 1	9 1	25 1	19 1	13 1	7 1
23 1	17 1	11 1	5 1				

fst = 2 Algorithm table : 22 Steps PULSE (WCMW) = 0

27 0	21 0	15 0	9 0	25 0	19 0	13 0	7 0
23 0	17 0	11 0	26 0	20 0	14 0	8 0	24 0
18 0	12 0	6 0	22 0	16 0	10 0		

fst = 2 Algorithm table : 11 Steps PULSE (WCMW) = 1

26 1	20 1	14 1	8 1	24 1	18 1	12 1	6 1
22 1	16 1	10 1					

fst = 3 Algorithm table : 21 Steps PULSE (WCMW) = 0

27 0	21 0	15 0	9 0	25 0	19 0	13 0	7 0
23 0	17 0	11 0	26 0	20 0	14 0	8 0	24 0
18 0	12 0	22 0	16 0	10 0			

fst = 3 Algorithm table : 11 Steps PULSE (WCMW) = 1

27 1	21 1	15 1	9 1	25 1	19 1	13 1	7 1
23 1	17 1	11 1					

fst = 4 Algorithm table : 20 Steps PULSE (WCMW) = 0

27 0	21 0	15 0	9 0	25 0	19 0	13 0	23 0
17 0	11 0	26 0	20 0	14 0	8 0	24 0	18 0
12 0	22 0	16 0	10 0				

fst = 4 Algorithm table : 10 Steps PULSE (WCMW) = 1

26 1	20 1	14 1	8 1	24 1	18 1	12 1	22 1
16 1	10 1						

fst = 5 Algorithm table : 18 Steps PULSE (WCMW) = 0

27 0	21 0	15 0	25 0	19 0	13 0	23 0	17 0
11 0	26 0	20 0	14 0	24 0	18 0	12 0	22 0
16 0	10 0						

fst = 5 Algorithm table : 9 Steps PULSE (WCMW) = 1

26 1	20 1	14 1	24 1	18 1	12 1	22 1	16 1
10 1							

fst = 6 Algorithm table : 16 Steps PULSE (WCMW) = 0

27 0	21 0	15 0	25 0	19 0	13 0	23 0	17 0
26 0	20 0	14 0	24 0	18 0	12 0	22 0	16 0

fst = 6 Algorithm table : 8 Steps PULSE (WCMW) = 1

26 1	20 1	14 1	24 1	18 1	12 1	22 1	16 1
------	------	------	------	------	------	------	------

fst = 7 Algorithm table : 14 Steps PULSE (WCMW) = 0

27 0 21 0 15 0 25 0 19 0 23 0 17 0 26 0
20 0 14 0 24 0 18 0 22 0 16 0

fst = 7 Algorithm table : 7 Steps PULSE (WCMW) = 1

26 1 20 1 14 1 24 1 18 1 22 1 16 1

fst = 8 Algorithm table : 12 Steps PULSE (WCMW) = 0

27 0 21 0 25 0 19 0 23 0 17 0 26 0 20 0
24 0 18 0 22 0 16 0

fst = 8 Algorithm table : 6 Steps PULSE (WCMW) = 1

26 1 20 1 24 1 18 1 22 1 16 1

fst = 9 Algorithm table : 10 Steps PULSE (WCMW) = 0

27 0 21 0 25 0 19 0 23 0 26 0 20 0 24 0
18 0 22 0

fst = 9 Algorithm table : 5 Steps PULSE (WCMW) = 1

26 1 20 1 24 1 18 1 22 1

fst = 10 Algorithm table : 6 Steps PULSE (WCMW) = 0

27 0 25 0 23 0 26 0 24 0 22 0

fst = 10 Algorithm table : 3 Steps PULSE (WCMW) = 1

26 1 24 1 22 1

fst = 11 Fixed table = 0 : 80 Steps PULSE (WCMW) = 0 or 1

83 0 82 0 81 0 80 0 79 0 78 0 77 0 76 0
75 0 74 0 73 0 72 0 71 0 70 0 69 0 68 0
67 0 66 0 65 0 64 0 63 0 62 0 61 0 60 0
59 0 58 0 57 0 56 0 55 0 54 0 53 0 52 0
51 0 50 0 49 0 48 0 47 0 46 0 45 0 44 0
43 0 42 0 41 0 40 0 39 0 38 0 37 0 36 0
35 0 34 0 33 0 32 0 31 0 30 0 29 0 28 0
27 0 26 0 25 0 24 0 23 0 22 0 21 0 20 0
19 0 18 0 17 0 16 0 15 0 14 0 13 0 12 0
11 0 10 0 9 0 8 0 7 0 6 0 5 0 4 0

fst = 12 Fixed table = 1 : 40 Steps PULSE (WCMW) = 0 or 1

82 1	80 1	78 1	76 1	74 1	72 1	70 1	68 1
66 1	64 1	62 1	60 1	58 1	56 1	54 1	52 1
50 1	48 1	46 1	44 1	42 1	40 1	38 1	36 1
34 1	32 1	30 1	28 1	26 1	24 1	22 1	20 1
18 1	16 1	14 1	12 1	10 1	8 1	6 1	4 1

fst = 13 Fixed table = 2 : 40 Steps PULSE (WCMW) = 0 or 1

43 0	42 0	41 0	40 0	39 0	38 0	37 0	36 0
35 0	34 0	33 0	32 0	31 0	30 0	29 0	28 0
27 0	26 0	25 0	24 0	23 0	22 0	21 0	20 0
19 0	18 0	17 0	16 0	15 0	14 0	13 0	12 0
11 0	10 0	9 0	8 0	7 0	6 0	5 0	4 0

fst = 14 Fixed table = 3 : 52 Steps PULSE (WCMW) = 0 or 1

82 1	70 1	58 1	46 1	34 1	78 1	66 1	54 1
42 1	30 1	74 1	62 1	50 1	38 1	80 1	68 1
56 1	44 1	32 1	76 1	64 1	52 1	40 1	28 1
72 1	60 1	48 1	36 1	27 0	21 0	15 0	9 0
25 0	19 0	13 0	7 0	23 0	17 0	11 0	5 0
26 0	20 0	14 0	8 0	24 0	18 0	12 0	6 0
22 0	16 0	10 0	4 0				

fst = 15 Fixed table = 4 : 58 Steps PULSE (WCMW) = 0 or 1

82 1	70 1	58 1	46 1	78 1	66 1	54 1	42 1
74 1	62 1	50 1	80 1	68 1	56 1	44 1	76 1
64 1	52 1	40 1	72 1	60 1	48 1	39 0	33 0
27 0	21 0	15 0	9 0	37 0	31 0	25 0	19 0
13 0	7 0	35 0	29 0	23 0	17 0	11 0	5 0
38 0	32 0	26 0	20 0	14 0	8 0	36 0	30 0
24 0	18 0	12 0	6 0	34 0	28 0	22 0	16 0
10 0	4 0						

fst = 16 Algorithm table : 32 Steps PULSE (WCMW) = 0

35 0	29 0	23 0	17 0	11 0	5 0	33 0	27 0
21 0	15 0	9 0	31 0	25 0	19 0	13 0	7 0
34 0	28 0	22 0	16 0	10 0	4 0	32 0	26 0
20 0	14 0	8 0	30 0	24 0	18 0	12 0	6 0

fst = 16 Algorithm table : 16 Steps PULSE (WCMW) = 1

34 1	28 1	22 1	16 1	10 1	4 1	32 1	26 1
20 1	14 1	8 1	30 1	24 1	18 1	12 1	6 1

fst = 17 Algorithm table : 31 Steps PULSE (WCMW) = 0

35 0	29 0	23 0	17 0	11 0	5 0	33 0	27 0
21 0	15 0	9 0	31 0	25 0	19 0	13 0	7 0
34 0	28 0	22 0	16 0	10 0	32 0	26 0	20 0
14 0	8 0	30 0	24 0	18 0	12 0	6 0	

fst = 17 Algorithm table : 16 Steps PULSE (WCMW) = 1

35 1	29 1	23 1	17 1	11 1	5 1	33 1	27 1
21 1	15 1	9 1	31 1	25 1	19 1	13 1	7 1

fst = 18 Algorithm table : 30 Steps PULSE (WCMW) = 0

35 0	29 0	23 0	17 0	11 0	33 0	27 0	21 0
15 0	9 0	31 0	25 0	19 0	13 0	7 0	34 0
28 0	22 0	16 0	10 0	32 0	26 0	20 0	14 0
8 0	30 0	24 0	18 0	12 0	6 0		

fst = 18 Algorithm table : 15 Steps PULSE (WCMW) = 1

34 1	28 1	22 1	16 1	10 1	32 1	26 1	20 1
14 1	8 1	30 1	24 1	18 1	12 1	6 1	

fst = 19 Algorithm table : 29 Steps PULSE (WCMW) = 0

35 0	29 0	23 0	17 0	11 0	33 0	27 0	21 0
15 0	9 0	31 0	25 0	19 0	13 0	7 0	34 0
28 0	22 0	16 0	10 0	32 0	26 0	20 0	14 0
8 0	30 0	24 0	18 0	12 0			

fst = 19 Algorithm table : 15 Steps PULSE (WCMW) = 1

35 1	29 1	23 1	17 1	11 1	33 1	27 1	21 1
15 1	9 1	31 1	25 1	19 1	13 1	7 1	

fst = 20 Algorithm table : 28 Steps PULSE (WCMW) = 0

35 0	29 0	23 0	17 0	11 0	33 0	27 0	21 0
15 0	9 0	31 0	25 0	19 0	13 0	34 0	28 0
22 0	16 0	10 0	32 0	26 0	20 0	14 0	8 0
30 0	24 0	18 0	12 0				

fst = 20 Algorithm table : 14 Steps PULSE (WCMW) = 1

34 1	28 1	22 1	16 1	10 1	32 1	26 1	20 1
14 1	8 1	30 1	24 1	18 1	12 1		

fst = 21 Algorithm table : 26 Steps PULSE (WCMW) = 0

35 0	29 0	23 0	17 0	11 0	33 0	27 0	21 0
15 0	31 0	25 0	19 0	13 0	34 0	28 0	22 0
16 0	10 0	32 0	26 0	20 0	14 0	30 0	24 0
18 0	12 0						

fst = 21 Algorithm table : 13 Steps PULSE (WCMW) = 1

34 1	28 1	22 1	16 1	10 1	32 1	26 1	20 1
14 1	30 1	24 1	18 1	12 1			

fst = 22 Algorithm table : 24 Steps PULSE (WCMW) = 0

35 0	29 0	23 0	17 0	33 0	27 0	21 0	15 0
31 0	25 0	19 0	13 0	34 0	28 0	22 0	16 0
32 0	26 0	20 0	14 0	30 0	24 0	18 0	12 0

fst = 22 Algorithm table : 12 Steps PULSE (WCMW) = 1

34 1	28 1	22 1	16 1	32 1	26 1	20 1	14 1
30 1	24 1	18 1	12 1				

fst = 23 Algorithm table : 22 Steps PULSE (WCMW) = 0

35 0	29 0	23 0	17 0	33 0	27 0	21 0	15 0
31 0	25 0	19 0	34 0	28 0	22 0	16 0	32 0
26 0	20 0	14 0	30 0	24 0	18 0		

fst = 23 Algorithm table : 11 Steps PULSE (WCMW) = 1

34 1	28 1	22 1	16 1	32 1	26 1	20 1	14 1
30 1	24 1	18 1					

fst = 24 Algorithm table : 20 Steps PULSE (WCMW) = 0

35 0	29 0	23 0	17 0	33 0	27 0	21 0	31 0
25 0	19 0	34 0	28 0	22 0	16 0	32 0	26 0
20 0	30 0	24 0	18 0				

fst = 24 Algorithm table : 10 Steps PULSE (WCMW) = 1

34 1	28 1	22 1	16 1	32 1	26 1	20 1	30 1
24 1	18 1						

fst = 25 Algorithm table : 18 Steps PULSE (WCMW) = 0

35 0	29 0	23 0	33 0	27 0	21 0	31 0	25 0
19 0	34 0	28 0	22 0	32 0	26 0	20 0	30 0
24 0	18 0						

fst = 25 Algorithm table : 9 Steps PULSE (WCMW) = 1

34 1	28 1	22 1	32 1	26 1	20 1	30 1	24 1
18 1							

fst = 26 Algorithm table : 14 Steps PULSE (WCMW) = 0

35 0	29 0	23 0	33 0	27 0	31 0	25 0	34 0
28 0	22 0	32 0	26 0	30 0	24 0		

fst = 26 Algorithm table : 7 Steps PULSE (WCMW) = 1

34 1	28 1	22 1	32 1	26 1	30 1	24 1	
------	------	------	------	------	------	------	--

fst = 27 Algorithm table : 10 Steps PULSE (WCMW) = 0

35 0 29 0 33 0 27 0 31 0 34 0 28 0 32 0
26 0 30 0

fst = 27 Algorithm table : 5 Steps PULSE (WCMW) = 1

34 1 28 1 32 1 26 1 30 1

fst = 28 Algorithm table : 6 Steps PULSE (WCMW) = 0

35 0 33 0 31 0 34 0 32 0 30 0

fst = 28 Algorithm table : 3 Steps PULSE (WCMW) = 1

34 1 32 1 30 1

fst = 29 Fixed table = 5 : 40 Steps PULSE (WCMW) = 0 or 1

62 1 50 1 38 1 26 1 58 1 46 1 34 1 22 1
66 1 54 1 42 1 30 1 60 1 48 1 36 1 24 1
56 1 44 1 32 1 20 1 64 1 52 1 40 1 28 1
19 0 13 0 7 0 17 0 11 0 5 0 15 0 9 0
18 0 12 0 6 0 16 0 10 0 4 0 14 0 8 0

fst = 30 Fixed table = 6 : 32 Steps PULSE (WCMW) = 0 or 1

36 1 24 1 40 1 28 1 44 1 32 1 38 1 26 1
42 1 30 1 46 1 34 1 23 0 17 0 11 0 5 0
21 0 15 0 9 0 19 0 13 0 7 0 22 0 16 0
10 0 4 0 20 0 14 0 8 0 18 0 12 0 6 0

fst = 31 Fixed table = 7 : 40 Steps PULSE (WCMW) = 0 or 1

60 1 48 1 36 1 24 1 64 1 52 1 40 1 28 1
68 1 56 1 44 1 32 1 62 1 50 1 38 1 26 1
54 1 42 1 30 1 58 1 46 1 34 1 23 0 17 0
11 0 21 0 15 0 9 0 19 0 13 0 7 0 22 0
16 0 10 0 20 0 14 0 8 0 18 0 12 0 6 0

fst = 32 Algorithm table : 40 Steps PULSE (WCMW) = 0

43 0 37 0 31 0 25 0 19 0 13 0 7 0 41 0
35 0 29 0 23 0 17 0 11 0 5 0 39 0 33 0
27 0 21 0 15 0 9 0 42 0 36 0 30 0 24 0
18 0 12 0 6 0 40 0 34 0 28 0 22 0 16 0
10 0 4 0 38 0 32 0 26 0 20 0 14 0 8 0

fst = 32 Algorithm table : 20 Steps PULSE (WCMW) = 1

42 1 36 1 30 1 24 1 18 1 12 1 6 1 40 1
34 1 28 1 22 1 16 1 10 1 4 1 38 1 32 1
26 1 20 1 14 1 8 1

fst = 33 Algorithm table : 39 Steps PULSE (WCMW) = 0

43 0	37 0	31 0	25 0	19 0	13 0	7 0	41 0
35 0	29 0	23 0	17 0	11 0	5 0	39 0	33 0
27 0	21 0	15 0	9 0	42 0	36 0	30 0	24 0
18 0	12 0	6 0	40 0	34 0	28 0	22 0	16 0
10 0	38 0	32 0	26 0	20 0	14 0	8 0	

fst = 33 Algorithm table : 20 Steps PULSE (WCMW) = 1

43 1	37 1	31 1	25 1	19 1	13 1	7 1	41 1
35 1	29 1	23 1	17 1	11 1	5 1	39 1	33 1
27 1	21 1	15 1	9 1				

fst = 34 Algorithm table : 38 Steps PULSE (WCMW) = 0

43 0	37 0	31 0	25 0	19 0	13 0	7 0	41 0
35 0	29 0	23 0	17 0	11 0	39 0	33 0	27 0
21 0	15 0	9 0	42 0	36 0	30 0	24 0	18 0
12 0	6 0	40 0	34 0	28 0	22 0	16 0	10 0
38 0	32 0	26 0	20 0	14 0	8 0		

fst = 34 Algorithm table : 19 Steps PULSE (WCMW) = 1

42 1	36 1	30 1	24 1	18 1	12 1	6 1	40 1
34 1	28 1	22 1	16 1	10 1	38 1	32 1	26 1
20 1	14 1	8 1					

fst = 35 Algorithm table : 37 Steps PULSE (WCMW) = 0

43 0	37 0	31 0	25 0	19 0	13 0	7 0	41 0
35 0	29 0	23 0	17 0	11 0	39 0	33 0	27 0
21 0	15 0	9 0	42 0	36 0	30 0	24 0	18 0
12 0	40 0	34 0	28 0	22 0	16 0	10 0	38 0
32 0	26 0	20 0	14 0	8 0			

fst = 35 Algorithm table : 19 Steps PULSE (WCMW) = 1

43 1	37 1	31 1	25 1	19 1	13 1	7 1	41 1
35 1	29 1	23 1	17 1	11 1	39 1	33 1	27 1
21 1	15 1	9 1					

fst = 36 Algorithm table : 36 Steps PULSE (WCMW) = 0

43 0	37 0	31 0	25 0	19 0	13 0	41 0	35 0
29 0	23 0	17 0	11 0	39 0	33 0	27 0	21 0
15 0	9 0	42 0	36 0	30 0	24 0	18 0	12 0
40 0	34 0	28 0	22 0	16 0	10 0	38 0	32 0
26 0	20 0	14 0	8 0				

fst = 36 Algorithm table : 18 Steps PULSE (WCMW) = 1

42 1	36 1	30 1	24 1	18 1	12 1	40 1	34 1
28 1	22 1	16 1	10 1	38 1	32 1	26 1	20 1
14 1	8 1						

fst = 37 Algorithm table : 34 Steps PULSE (WCMW) = 0

43 0	37 0	31 0	25 0	19 0	13 0	41 0	35 0
29 0	23 0	17 0	11 0	39 0	33 0	27 0	21 0
15 0	42 0	36 0	30 0	24 0	18 0	12 0	40 0
34 0	28 0	22 0	16 0	10 0	38 0	32 0	26 0
20 0	14 0						

fst = 37 Algorithm table : 17 Steps PULSE (WCMW) = 1

42 1	36 1	30 1	24 1	18 1	12 1	40 1	34 1
28 1	22 1	16 1	10 1	38 1	32 1	26 1	20 1
14 1							

fst = 38 Algorithm table : 32 Steps PULSE (WCMW) = 0

43 0	37 0	31 0	25 0	19 0	13 0	41 0	35 0
29 0	23 0	17 0	39 0	33 0	27 0	21 0	15 0
42 0	36 0	30 0	24 0	18 0	12 0	40 0	34 0
28 0	22 0	16 0	38 0	32 0	26 0	20 0	14 0

fst = 38 Algorithm table : 16 Steps PULSE (WCMW) = 1

42 1	36 1	30 1	24 1	18 1	12 1	40 1	34 1
28 1	22 1	16 1	38 1	32 1	26 1	20 1	14 1

fst = 39 Algorithm table : 30 Steps PULSE (WCMW) = 0

43 0	37 0	31 0	25 0	19 0	41 0	35 0	29 0
23 0	17 0	39 0	33 0	27 0	21 0	15 0	42 0
36 0	30 0	24 0	18 0	40 0	34 0	28 0	22 0
16 0	38 0	32 0	26 0	20 0	14 0		

fst = 39 Algorithm table : 15 Steps PULSE (WCMW) = 1

42 1	36 1	30 1	24 1	18 1	40 1	34 1	28 1
22 1	16 1	38 1	32 1	26 1	20 1	14 1	

fst = 40 Algorithm table : 28 Steps PULSE (WCMW) = 0

43 0	37 0	31 0	25 0	19 0	41 0	35 0	29 0
23 0	17 0	39 0	33 0	27 0	21 0	42 0	36 0
30 0	24 0	18 0	40 0	34 0	28 0	22 0	16 0
38 0	32 0	26 0	20 0				

fst = 40 Algorithm table : 14 Steps PULSE (WCMW) = 1

42 1	36 1	30 1	24 1	18 1	40 1	34 1	28 1
22 1	16 1	38 1	32 1	26 1	20 1		

fst = 41 Algorithm table : 26 Steps PULSE (WCMW) = 0

43 0	37 0	31 0	25 0	19 0	41 0	35 0	29 0
23 0	39 0	33 0	27 0	21 0	42 0	36 0	30 0
24 0	18 0	40 0	34 0	28 0	22 0	38 0	32 0

fst = 41 Algorithm table : 13 Steps PULSE (WCMW) = 1

42 1 36 1 30 1 24 1 18 1 40 1 34 1 28 1
22 1 38 1 32 1 26 1 20 1

fst = 42 Algorithm table : 22 Steps PULSE (WCMW) = 0

43 0 37 0 31 0 25 0 41 0 35 0 29 0 23 0
39 0 33 0 27 0 42 0 36 0 30 0 24 0 40 0
34 0 28 0 22 0 38 0 32 0 26 0

fst = 42 Algorithm table : 11 Steps PULSE (WCMW) = 1

42 1 36 1 30 1 24 1 40 1 34 1 28 1 22 1
38 1 32 1 26 1

fst = 43 Algorithm table : 18 Steps PULSE (WCMW) = 0

43 0 37 0 31 0 41 0 35 0 29 0 39 0 33 0
27 0 42 0 36 0 30 0 40 0 34 0 28 0 38 0
32 0 26 0

fst = 43 Algorithm table : 9 Steps PULSE (WCMW) = 1

42 1 36 1 30 1 40 1 34 1 28 1 38 1 32 1
26 1

fst = 44 Algorithm table : 14 Steps PULSE (WCMW) = 0

43 0 37 0 31 0 41 0 35 0 39 0 33 0 42 0
36 0 30 0 40 0 34 0 38 0 32 0

fst = 44 Algorithm table : 7 Steps PULSE (WCMW) = 1

42 1 36 1 30 1 40 1 34 1 38 1 32 1

fst = 45 Algorithm table : 10 Steps PULSE (WCMW) = 0

43 0 37 0 41 0 35 0 39 0 42 0 36 0 40 0
34 0 38 0

fst = 45 Algorithm table : 5 Steps PULSE (WCMW) = 1

42 1 36 1 40 1 34 1 38 1

fst = 46 Algorithm table : 6 Steps PULSE (WCMW) = 0

43 0 41 0 39 0 42 0 40 0 38 0

fst = 46 Algorithm table : 3 Steps PULSE (WCMW) = 1

42 1 40 1 38 1

fst = 47 Fixed table = 8 : 36 Steps PULSE (WCMW) = 0 or 1

	62 1	50 1	38 1	26 1	58 1	46 1	34 1	22 1
	54 1	42 1	30 1	60 1	48 1	36 1	24 1	18 1
56 1	44 1	32 1	20 1	52 1	40 1	28 1	13 0	
	7 0	17 0	11 0	5 0	15 0	9 0	12 0	6 0
	16 0	10 0	14 0	8 0				

fst = 48 Algorithm table : 48 Steps PULSE (WCMW) = 0

51 0	45 0	39 0	33 0	27 0	21 0	15 0	9 0
49 0	43 0	37 0	31 0	25 0	19 0	13 0	7 0
47 0	41 0	35 0	29 0	23 0	17 0	11 0	5 0
50 0	44 0	38 0	32 0	26 0	20 0	14 0	8 0
48 0	42 0	36 0	30 0	24 0	18 0	12 0	6 0
46 0	40 0	34 0	28 0	22 0	16 0	10 0	4 0

fst = 48 Algorithm table : 24 Steps PULSE (WCMW) = 1

50 1	44 1	38 1	32 1	26 1	20 1	14 1	8 1
48 1	42 1	36 1	30 1	24 1	18 1	12 1	6 1
46 1	40 1	34 1	28 1	22 1	16 1	10 1	4 1

fst = 49 Algorithm table : 47 Steps PULSE (WCMW) = 0

51 0	45 0	39 0	33 0	27 0	21 0	15 0	9 0
49 0	43 0	37 0	31 0	25 0	19 0	13 0	7 0
47 0	41 0	35 0	29 0	23 0	17 0	11 0	5 0
50 0	44 0	38 0	32 0	26 0	20 0	14 0	8 0
48 0	42 0	36 0	30 0	24 0	18 0	12 0	6 0
46 0	40 0	34 0	28 0	22 0	16 0	10 0	

fst = 49 Algorithm table : 24 Steps PULSE (WCMW) = 1

51 1	45 1	39 1	33 1	27 1	21 1	15 1	9 1
49 1	43 1	37 1	31 1	25 1	19 1	13 1	7 1
47 1	41 1	35 1	29 1	23 1	17 1	11 1	5 1

fst = 50 Algorithm table : 46 Steps PULSE (WCMW) = 0

	51 0	45 0	39 0	33 0	27 0	21 0	15 0	9 0
	49 0	43 0	37 0	31 0	25 0	19 0	13 0	7 0
	47 0	41 0	35 0	29 0	23 0	17 0	11 0	5 0 0
	44 0	38 0	32 0	26 0	20 0	14 0	8 0	4 8 0
	42 0	36 0	30 0	24 0	18 0	12 0	6 0	4 6 0
40 0	34 0	28 0	22 0	16 0	10 0			

fst = 50 Algorithm table : 23 Steps PULSE (WCMW) = 1

50 1	44 1	38 1	32 1	26 1	20 1	14 1	8 1
48 1	42 1	36 1	30 1	24 1	18 1	12 1	6 1
46 1	40 1	34 1	28 1	22 1	16 1	10 1	

fst = 51 Algorithm table : 45 Steps PULSE (WCMW) = 0

51 0	45 0	39 0	33 0	27 0	21 0	15 0	9 0
49 0	43 0	37 0	31 0	25 0	19 0	13 0	7 0
47 0	41 0	35 0	29 0	23 0	17 0	11 0	5 0
44 0	38 0	32 0	26 0	20 0	14 0	8 0	4 0
42 0	36 0	30 0	24 0	18 0	12 0	4 6 0	4 0 0
34 0	28 0	22 0	16 0	10 0			

fst = 51 Algorithm table : 23 Steps PULSE (WCMW) = 1

51 1	45 1	39 1	33 1	27 1	21 1	15 1	9 1
49 1	43 1	37 1	31 1	25 1	19 1	13 1	7 1
47 1	41 1	35 1	29 1	23 1	17 1	11 1	

fst = 52 Algorithm table : 44 Steps PULSE (WCMW) = 0

51 0	45 0	39 0	33 0	27 0	21 0	15 0	9 0
49 0	43 0	37 0	31 0	25 0	19 0	13 0	4 7 0
41 0	35 0	29 0	23 0	17 0	11 0	5 0 0	4 4 0
38 0	32 0	26 0	20 0	14 0	8 0	4 8 0	4 2 0
36 0	30 0	24 0	18 0	12 0	4 6 0	4 0 0	3 4 0
28 0	22 0	16 0	10 0				

fst = 52 Algorithm table : 22 Steps PULSE (WCMW) = 1

50 1	44 1	38 1	32 1	26 1	20 1	14 1	8 1
48 1	42 1	36 1	30 1	24 1	18 1	12 1	4 6 1
40 1	34 1	28 1	22 1	16 1	10 1		

fst = 53 Algorithm table : 42 Steps PULSE (WCMW) = 0

51 0	45 0	39 0	33 0	27 0	21 0	15 0	4 9 0
43 0	37 0	31 0	25 0	19 0	13 0	4 7 0	4 1 0
35 0	29 0	23 0	17 0	11 0	5 0 0	4 4 0	3 8 0
32 0	26 0	20 0	14 0	4 8 0	4 2 0	3 6 0	3 0 0
24 0	18 0	12 0	4 6 0	4 0 0	3 4 0	2 8 0	2 2 0
16 0	10 0						

fst = 53 Algorithm table : 21 Steps PULSE (WCMW) = 1

50 1	44 1	38 1	32 1	26 1	20 1	14 1	4 8 1
42 1	36 1	30 1	24 1	18 1	12 1	4 6 1	4 0 1
34 1	28 1	22 1	16 1	10 1			

fst = 54 Algorithm table : 40 Steps PULSE (WCMW) = 0

51 0	45 0	39 0	33 0	27 0	21 0	15 0	4 9 0
43 0	37 0	31 0	25 0	19 0	13 0	4 7 0	4 1 0
35 0	29 0	23 0	17 0	5 0 0	4 4 0	3 8 0	3 2 0
26 0	20 0	14 0	4 8 0	4 2 0	3 6 0	3 0 0	2 4 0
18 0	12 0	4 6 0	4 0 0	3 4 0	2 8 0	2 2 0	1 6 0

fst = 54 Algorithm table : 20 Steps PULSE (WCMW) = 1

50 1	44 1	38 1	32 1	26 1	20 1	14 1	48 1
42 1	36 1	30 1	24 1	18 1	12 1	46 1	40 1
34 1	28 1	22 1	16 1				

fst = 55 Algorithm table : 38 Steps PULSE (WCMW) = 0

51 0	45 0	39 0	33 0	27 0	21 0	15 0	49 0
43 0	37 0	31 0	25 0	19 0	47 0	41 0	35 0
29 0	23 0	17 0	50 0	44 0	38 0	32 0	26 0
20 0	14 0	48 0	42 0	36 0	30 0	24 0	18 0
46 0	40 0	34 0	28 0	22 0	16 0		

fst = 55 Algorithm table : 19 Steps PULSE (WCMW) = 1

50 1	44 1	38 1	32 1	26 1	20 1	14 1	48 1
42 1	36 1	30 1	24 1	18 1	46 1	40 1	34 1
28 1	22 1	16 1					

fst = 56 Algorithm table : 36 Steps PULSE (WCMW) = 0

51 0	45 0	39 0	33 0	27 0	21 0	49 0	43 0
37 0	31 0	25 0	19 0	47 0	41 0	35 0	29 0
23 0	17 0	50 0	44 0	38 0	32 0	26 0	20 0
48 0	42 0	36 0	30 0	24 0	18 0	46 0	40 0
34 0	28 0	22 0	16 0				

fst = 56 Algorithm table : 18 Steps PULSE (WCMW) = 1

50 1	44 1	38 1	32 1	26 1	20 1	48 1	42 1
36 1	30 1	24 1	18 1	46 1	40 1	34 1	28 1
22 1	16 1						

fst = 57 Algorithm table : 34 Steps PULSE (WCMW) = 0

51 0	45 0	39 0	33 0	27 0	21 0	49 0	43 0
37 0	31 0	25 0	19 0	47 0	41 0	35 0	29 0
23 0	50 0	44 0	38 0	32 0	26 0	20 0	48 0
42 0	36 0	30 0	24 0	18 0	46 0	40 0	34 0
28 0	22 0						

fst = 57 Algorithm table : 17 Steps PULSE (WCMW) = 1

50 1	44 1	38 1	32 1	26 1	20 1	48 1	42 1
36 1	30 1	24 1	18 1	46 1	40 1	34 1	28 1
22 1							

fst = 58 Fixed table = 9 : 40 Steps PULSE (WCMW) = 0 or 1

75 1	67 1	59 1	51 1	43 1	35 1	27 1	19 1
11 1	7 0	73 1	65 1	57 1	49 1	41 1	33 1
25 1	17 1	10 0	6 0	71 1	63 1	55 1	47 1
39 1	31 1	23 1	15 1	9 0	5 0	69 1	61 1
53 1	45 1	37 1	29 1	21 1	13 1	8 0	4 0

fst = 59 Fixed table = 10 : 38 Steps PULSE (WCMW) = 0 or 1

79 1	75 1	71 1	67 1	63 1	59 1	55 1	51 1
47 1	43 1	39 1	35 1	31 1	27 1	23 1	19 1
15 1	11 1	7 1	77 1	73 1	69 1	65 1	61 1
57 1	53 1	49 1	45 1	41 1	37 1	33 1	29 1
25 1	21 1	17 1	13 1	9 1	5 1		

fst = 60 Fixed table = 11 : 36 Steps PULSE (WCMW) = 0 or 1

75 1	71 1	67 1	63 1	59 1	55 1	51 1	47 1
43 1	39 1	35 1	31 1	27 1	23 1	19 1	15 1
11 1	7 1	73 1	69 1	65 1	61 1	57 1	53 1
49 1	45 1	41 1	37 1	33 1	29 1	25 1	21 1
17 1	13 1	9 1	5 1				

fst = 61 Fixed table = 12 : 34 Steps PULSE (WCMW) = 0 or 1

71 1	67 1	63 1	59 1	55 1	51 1	47 1	43 1
39 1	35 1	31 1	27 1	23 1	19 1	15 1	11 1
7 1	69 1	65 1	61 1	57 1	53 1	49 1	45 1
41 1	37 1	33 1	29 1	25 1	21 1	17 1	13 1
9 1	5 1						

fst = 62 Fixed table = 13 : 32 Steps PULSE (WCMW) = 0 or 1

67 1	63 1	59 1	55 1	51 1	47 1	43 1	39 1
35 1	31 1	27 1	23 1	19 1	15 1	11 1	7 1
65 1	61 1	57 1	53 1	49 1	45 1	41 1	37 1
33 1	29 1	25 1	21 1	17 1	13 1	9 1	5 1

fst = 63 Algorithm table : 10 Steps PULSE (WCMW) = 0

51 0	45 0	49 0	43 0	47 0	50 0	44 0	48 0
42 0	46 0						

fst = 63 Algorithm table : 5 Steps PULSE (WCMW) = 1

50 1	44 1	48 1	42 1	46 1
------	------	------	------	------

fst = 64 Algorithm table : 56 Steps PULSE (WCMW) = 0

59 0	53 0	47 0	41 0	35 0	29 0	23 0	17 0
11 0	5 0	57 0	51 0	45 0	39 0	33 0	27 0
21 0	15 0	9 0	55 0	49 0	43 0	37 0	31 0
25 0	19 0	13 0	7 0	58 0	52 0	46 0	40 0
34 0	28 0	22 0	16 0	10 0	4 0	56 0	50 0
44 0	38 0	32 0	26 0	20 0	14 0	8 0	54 0

480 420 360 300 240 180 120 60

fst = 64 Algorithm table : 28 Steps PULSE (WCMW) = 1

58 1	52 1	46 1	40 1	34 1	28 1	22 1	16 1
10 1	4 1	56 1	50 1	44 1	38 1	32 1	26 1
20 1	14 1	8 1	54 1	48 1	42 1	36 1	30 1
24 1	18 1	12 1	6 1				

fst = 65 Algorithm table : 55 Steps PULSE (WCMW) = 0

59 0	53 0	47 0	41 0	35 0	29 0	23 0	17 0
11 0	5 0	57 0	51 0	45 0	39 0	33 0	27 0
21 0	15 0	9 0	55 0	49 0	43 0	37 0	31 0
25 0	19 0	13 0	7 0	58 0	52 0	46 0	40 0
34 0	28 0	22 0	16 0	10 0	56 0	50 0	44 0
38 0	32 0	26 0	20 0	14 0	8 0	54 0	48 0
42 0	36 0	30 0	24 0	18 0	12 0	6 0	

fst = 65 Algorithm table : 28 Steps PULSE (WCMW) = 1

59 1	53 1	47 1	41 1	35 1	29 1	23 1	17 1
11 1	5 1	57 1	51 1	45 1	39 1	33 1	27 1
21 1	15 1	9 1	55 1	49 1	43 1	37 1	31 1
25 1	19 1	13 1	7 1				

fst = 66 Algorithm table : 54 Steps PULSE (WCMW) = 0

59 0	53 0	47 0	41 0	35 0	29 0	23 0	17 0
11 0	57 0	51 0	45 0	39 0	33 0	27 0	21 0
15 0	9 0	55 0	49 0	43 0	37 0	31 0	25 0
19 0	13 0	7 0	58 0	52 0	46 0	40 0	34 0
28 0	22 0	16 0	10 0	56 0	50 0	44 0	38 0
32 0	26 0	20 0	14 0	8 0	54 0	48 0	42 0
36 0	30 0	24 0	18 0	12 0	6 0		

fst = 66 Algorithm table : 27 Steps PULSE (WCMW) = 1

58 1	52 1	46 1	40 1	34 1	28 1	22 1	16 1
10 1	56 1	50 1	44 1	38 1	32 1	26 1	20 1
14 1	8 1	54 1	48 1	42 1	36 1	30 1	24 1
18 1	12 1	6 1					

fst = 67 Algorithm table : 53 Steps PULSE (WCMW) = 0

59 0	53 0	47 0	41 0	35 0	29 0	23 0	17 0
11 0	57 0	51 0	45 0	39 0	33 0	27 0	21 0
15 0	9 0	55 0	49 0	43 0	37 0	31 0	25 0
19 0	13 0	7 0	58 0	52 0	46 0	40 0	34 0
28 0	22 0	16 0	10 0	56 0	50 0	44 0	38 0
32 0	26 0	20 0	14 0	8 0	54 0	48 0	42 0
36 0	30 0	24 0	18 0	12 0			

fst = 67 Algorithm table : 27 Steps PULSE (WCMW) = 1

59 1	53 1	47 1	41 1	35 1	29 1	23 1	17 1
11 1	57 1	51 1	45 1	39 1	33 1	27 1	21 1
15 1	9 1	55 1	49 1	43 1	37 1	31 1	25 1

fst = 68 Algorithm table : 52 Steps PULSE (WCMW) = 0

59 0	53 0	47 0	41 0	35 0	29 0	23 0	17 0
11 0	57 0	51 0	45 0	39 0	33 0	27 0	21 0
15 0	9 0	55 0	49 0	43 0	37 0	31 0	25 0
19 0	13 0	58 0	52 0	46 0	40 0	34 0	28 0
22 0	16 0	10 0	56 0	50 0	44 0	38 0	32 0
26 0	20 0	14 0	8 0	54 0	48 0	42 0	36 0
30 0	24 0	18 0	12 0				

fst = 68 Algorithm table : 26 Steps PULSE (WCMW) = 1

58 1	52 1	46 1	40 1	34 1	28 1	22 1	16 1
10 1	56 1	50 1	44 1	38 1	32 1	26 1	20 1
14 1	8 1	54 1	48 1	42 1	36 1	30 1	24 1
18 1	12 1						

fst = 69 Algorithm table : 50 Steps PULSE (WCMW) = 0

59 0	53 0	47 0	41 0	35 0	29 0	23 0	17 0
11 0	57 0	51 0	45 0	39 0	33 0	27 0	21 0
15 0	55 0	49 0	43 0	37 0	31 0	25 0	19 0
13 0	58 0	52 0	46 0	40 0	34 0	28 0	22 0
16 0	10 0	56 0	50 0	44 0	38 0	32 0	26 0
20 0	14 0	54 0	48 0	42 0	36 0	30 0	24 0
18 0	12 0						

fst = 69 Algorithm table : 25 Steps PULSE (WCMW) = 1

58 1	52 1	46 1	40 1	34 1	28 1	22 1	16 1
10 1	56 1	50 1	44 1	38 1	32 1	26 1	20 1
14 1	54 1	48 1	42 1	36 1	30 1	24 1	18 1
12 1							

fst = 70 Algorithm table : 48 Steps PULSE (WCMW) = 0

59 0	53 0	47 0	41 0	35 0	29 0	23 0	17 0
57 0	51 0	45 0	39 0	33 0	27 0	21 0	15 0
55 0	49 0	43 0	37 0	31 0	25 0	19 0	13 0
58 0	52 0	46 0	40 0	34 0	28 0	22 0	16 0
56 0	50 0	44 0	38 0	32 0	26 0	20 0	14 0
54 0	48 0	42 0	36 0	30 0	24 0	18 0	12 0

fst = 70 Algorithm table : 24 Steps PULSE (WCMW) = 1

58 1	52 1	46 1	40 1	34 1	28 1	22 1	16 1
56 1	50 1	44 1	38 1	32 1	26 1	20 1	14 1
54 1	48 1	42 1	36 1	30 1	24 1	18 1	12 1

fst = 71 Fixed table = 14 : 39 Steps PULSE (WCMW) = 0 or 1

81 1	75 1	69 1	63 1	57 1	51 1	45 1	39 1
33 1	27 1	21 1	15 1	9 1	79 1	73 1	67 1
61 1	55 1	49 1	43 1	37 1	31 1	25 1	19 1
13 1	7 1	77 1	71 1	65 1	59 1	53 1	47 1
41 1	35 1	29 1	23 1	17 1	11 1	5 1	

fst = 72 Fixed table = 15 : 38 Steps PULSE (WCMW) = 0 or 1

79 1 73 1 67 1 61 1 55 1 49 1 43 1 37 1
31 1 25 1 19 1 13 1 7 1 77 1 71 1 65 1
59 1 53 1 47 1 41 1 35 1 29 1 23 1 17 1
11 1 5 1 75 1 69 1 63 1 57 1 51 1 45 1
39 1 33 1 27 1 21 1 15 1 9 1

fst = 73 Fixed table = 16 : 37 Steps PULSE (WCMW) = 0 or 1

77 1 71 1 65 1 59 1 53 1 47 1 41 1 35 1
29 1 23 1 17 1 11 1 5 1 75 1 69 1 63 1
57 1 51 1 45 1 39 1 33 1 27 1 21 1 15 1
9 1 73 1 67 1 61 1 55 1 49 1 43 1 37 1
31 1 25 1 19 1 13 1 7 1

fst = 74 Fixed table = 17 : 35 Steps PULSE (WCMW) = 0 or 1

73 1 67 1 61 1 55 1 49 1 43 1 37 1 31 1
25 1 19 1 13 1 7 1 71 1 65 1 59 1 53 1
47 1 41 1 35 1 29 1 23 1 17 1 11 1 5 1
69 1 63 1 57 1 51 1 45 1 39 1 33 1 27 1
21 1 15 1 9 1

fst = 75 Fixed table = 18 : 34 Steps PULSE (WCMW) = 0 or 1

71 1 65 1 59 1 53 1 47 1 41 1 35 1 29 1
23 1 17 1 11 1 5 1 69 1 63 1 57 1 51 1
45 1 39 1 33 1 27 1 21 1 15 1 9 1 67 1
61 1 55 1 49 1 43 1 37 1 31 1 25 1 19 1
13 1 7 1

fst = 76 Fixed table = 19 : 33 Steps PULSE (WCMW) = 0 or 1

69 1 63 1 57 1 51 1 45 1 39 1 33 1 27 1
21 1 15 1 9 1 67 1 61 1 55 1 49 1 43 1
37 1 31 1 25 1 19 1 13 1 7 1 65 1 59 1
53 1 47 1 41 1 35 1 29 1 23 1 17 1 11 1
5 1

fst = 77 Fixed table = 20 : 21 Steps PULSE (WCMW) = 0 or 1

45 1 41 1 37 1 33 1 29 1 25 1 21 1 17 1
13 1 9 1 5 1 43 1 39 1 35 1 31 1 27 1
23 1 19 1 15 1 11 1 7 1

fst = 78 Fixed table = 21 : 46 Steps PULSE (WCMW) = 0 or 1

49 0 45 0 41 0 37 0 33 0 29 0 25 0 21 0
17 0 13 0 9 0 5 0 48 0 44 0 40 0 36 0
32 0 28 0 24 0 20 0 16 0 12 0 8 0 4 0
47 0 43 0 39 0 35 0 31 0 27 0 23 0 19 0
15 0 11 0 7 0 46 0 42 0 38 0 34 0 30 0
26 0 22 0 18 0 14 0 10 0 6 0

fst = 79 Algorithm table : 18 Steps PULSE (WCMW) = 0

59 0	53 0	47 0	57 0	51 0	45 0	55 0	49 0
43 0	58 0	52 0	46 0	56 0	50 0	44 0	54 0
48 0	42 0						

fst = 79 Algorithm table : 9 Steps PULSE (WCMW) = 1

58 1	52 1	46 1	56 1	50 1	44 1	54 1	48 1
42 1							

fst = 80 Algorithm table : 64 Steps PULSE (WCMW) = 0

67 0	61 0	55 0	49 0	43 0	37 0	31 0	25 0
19 0	13 0	7 0	65 0	59 0	53 0	47 0	41 0
35 0	29 0	23 0	17 0	11 0	5 0	63 0	57 0
51 0	45 0	39 0	33 0	27 0	21 0	15 0	9 0
66 0	60 0	54 0	48 0	42 0	36 0	30 0	24 0
18 0	12 0	6 0	64 0	58 0	52 0	46 0	40 0
34 0	28 0	22 0	16 0	10 0	4 0	62 0	56 0
50 0	44 0	38 0	32 0	26 0	20 0	14 0	8 0

fst = 80 Algorithm table : 32 Steps PULSE (WCMW) = 1

66 1	60 1	54 1	48 1	42 1	36 1	30 1	24 1
18 1	12 1	6 1	64 1	58 1	52 1	46 1	40 1
34 1	28 1	22 1	16 1	10 1	4 1	62 1	56 1
50 1	44 1	38 1	32 1	26 1	20 1	14 1	8 1

fst = 81 Algorithm table : 63 Steps PULSE (WCMW) = 0

67 0	61 0	55 0	49 0	43 0	37 0	31 0	25 0
19 0	13 0	7 0	65 0	59 0	53 0	47 0	41 0
35 0	29 0	23 0	17 0	11 0	5 0	63 0	57 0
51 0	45 0	39 0	33 0	27 0	21 0	15 0	9 0
66 0	60 0	54 0	48 0	42 0	36 0	30 0	24 0
18 0	12 0	6 0	64 0	58 0	52 0	46 0	40 0
34 0	28 0	22 0	16 0	10 0	62 0	56 0	50 0
44 0	38 0	32 0	26 0	20 0	14 0	8 0	

fst = 81 Algorithm table : 32 Steps PULSE (WCMW) = 1

67 1	61 1	55 1	49 1	43 1	37 1	31 1	25 1
19 1	13 1	7 1	65 1	59 1	53 1	47 1	41 1
35 1	29 1	23 1	17 1	11 1	5 1	63 1	57 1
51 1	45 1	39 1	33 1	27 1	21 1	15 1	9 1

fst = 82 Algorithm table : 62 Steps PULSE (WCMW) = 0

67 0	61 0	55 0	49 0	43 0	37 0	31 0	25 0
19 0	13 0	7 0	65 0	59 0	53 0	47 0	41 0
35 0	29 0	23 0	17 0	11 0	63 0	57 0	51 0
45 0	39 0	33 0	27 0	21 0	15 0	9 0	66 0
60 0	54 0	48 0	42 0	36 0	30 0	24 0	18 0
12 0	6 0	64 0	58 0	52 0	46 0	40 0	34 0
28 0	22 0	16 0	10 0	62 0	56 0	50 0	44 0

380 320 260 200 140 80

fst = 82 Algorithm table : 31 Steps PULSE (WCMW) = 1

66 1	60 1	54 1	48 1	42 1	36 1	30 1	24 1
18 1	12 1	6 1	64 1	58 1	52 1	46 1	40 1
34 1	28 1	22 1	16 1	10 1	62 1	56 1	50 1
44 1	38 1	32 1	26 1	20 1	14 1	8 1	

fst = 83 Algorithm table : 61 Steps PULSE (WCMW) = 0

67 0	61 0	55 0	49 0	43 0	37 0	31 0	25 0
19 0	13 0	7 0	65 0	59 0	53 0	47 0	41 0
35 0	29 0	23 0	17 0	11 0	63 0	57 0	51 0
45 0	39 0	33 0	27 0	21 0	15 0	9 0	66 0
60 0	54 0	48 0	42 0	36 0	30 0	24 0	18 0
12 0	64 0	58 0	52 0	46 0	40 0	34 0	28 0
22 0	16 0	10 0	62 0	56 0	50 0	44 0	38 0
32 0	26 0	20 0	14 0	8 0			

fst = 83 Algorithm table : 31 Steps PULSE (WCMW) = 1

67 1	61 1	55 1	49 1	43 1	37 1	31 1	25 1
19 1	13 1	7 1	65 1	59 1	53 1	47 1	41 1
35 1	29 1	23 1	17 1	11 1	63 1	57 1	51 1
45 1	39 1	33 1	27 1	21 1	15 1	9 1	

fst = 84 Algorithm table : 60 Steps PULSE (WCMW) = 0

67 0	61 0	55 0	49 0	43 0	37 0	31 0	25 0
19 0	13 0	65 0	59 0	53 0	47 0	41 0	35 0
29 0	23 0	17 0	11 0	63 0	57 0	51 0	45 0
39 0	33 0	27 0	21 0	15 0	9 0	66 0	60 0
54 0	48 0	42 0	36 0	30 0	24 0	18 0	12 0
64 0	58 0	52 0	46 0	40 0	34 0	28 0	22 0
16 0	10 0	62 0	56 0	50 0	44 0	38 0	32 0
26 0	20 0	14 0	8 0				

fst = 84 Algorithm table : 30 Steps PULSE (WCMW) = 1

66 1	60 1	54 1	48 1	42 1	36 1	30 1	24 1
18 1	12 1	64 1	58 1	52 1	46 1	40 1	34 1
28 1	22 1	16 1	10 1	62 1	56 1	50 1	44 1
38 1	32 1	26 1	20 1	14 1	8 1		

fst = 85 Algorithm table : 58 Steps PULSE (WCMW) = 0

67 0	61 0	55 0	49 0	43 0	37 0	31 0	25 0
19 0	13 0	65 0	59 0	53 0	47 0	41 0	35 0
29 0	23 0	17 0	11 0	63 0	57 0	51 0	45 0
39 0	33 0	27 0	21 0	15 0	66 0	60 0	54 0
48 0	42 0	36 0	30 0	24 0	18 0	12 0	64 0
58 0	52 0	46 0	40 0	34 0	28 0	22 0	16 0
10 0	62 0	56 0	50 0	44 0	38 0	32 0	26 0
20 0	14 0						

fst = 85 Algorithm table : 29 Steps PULSE (WCMW) = 1

66 1	60 1	54 1	48 1	42 1	36 1	30 1	24 1
18 1	12 1	64 1	58 1	52 1	46 1	40 1	34 1
28 1	22 1	16 1	10 1	62 1	56 1	50 1	44 1
38 1	32 1	26 1	20 1	14 1			

fst = 86 Algorithm table : 56 Steps PULSE (WCMW) = 0

67 0	61 0	55 0	49 0	43 0	37 0	31 0	25 0
19 0	13 0	65 0	59 0	53 0	47 0	41 0	35 0
29 0	23 0	17 0	63 0	57 0	51 0	45 0	39 0
33 0	27 0	21 0	15 0	66 0	60 0	54 0	48 0
42 0	36 0	30 0	24 0	18 0	12 0	64 0	58 0
52 0	46 0	40 0	34 0	28 0	22 0	16 0	62 0
56 0	50 0	44 0	38 0	32 0	26 0	20 0	14 0

fst = 86 Algorithm table : 28 Steps PULSE (WCMW) = 1

66 1	60 1	54 1	48 1	42 1	36 1	30 1	24 1
18 1	12 1	64 1	58 1	52 1	46 1	40 1	34 1
28 1	22 1	16 1	62 1	56 1	50 1	44 1	38 1
32 1	26 1	20 1	14 1				

fst = 87 Algorithm table : 54 Steps PULSE (WCMW) = 0

67 0	61 0	55 0	49 0	43 0	37 0	31 0	25 0
19 0	65 0	59 0	53 0	47 0	41 0	35 0	29 0
23 0	17 0	63 0	57 0	51 0	45 0	39 0	33 0
27 0	21 0	15 0	66 0	60 0	54 0	48 0	42 0
36 0	30 0	24 0	18 0	64 0	58 0	52 0	46 0
40 0	34 0	28 0	22 0	16 0	62 0	56 0	50 0
44 0	38 0	32 0	26 0	20 0	14 0		

fst = 87 Algorithm table : 27 Steps PULSE (WCMW) = 1

66 1	60 1	54 1	48 1	42 1	36 1	30 1	24 1
18 1	64 1	58 1	52 1	46 1	40 1	34 1	28 1
22 1	16 1	62 1	56 1	50 1	44 1	38 1	32 1
26 1	20 1	14 1					

fst = 88 Algorithm table : 52 Steps PULSE (WCMW) = 0

67 0	61 0	55 0	49 0	43 0	37 0	31 0	25 0
19 0	65 0	59 0	53 0	47 0	41 0	35 0	29 0
23 0	17 0	63 0	57 0	51 0	45 0	39 0	33 0
27 0	21 0	66 0	60 0	54 0	48 0	42 0	36 0
30 0	24 0	18 0	64 0	58 0	52 0	46 0	40 0
34 0	28 0	22 0	16 0	62 0	56 0	50 0	44 0
38 0	32 0	26 0	20 0				

fst = 88 Algorithm table : 26 Steps PULSE (WCMW) = 1

66 1	60 1	54 1	48 1	42 1	36 1	30 1	24 1
18 1	64 1	58 1	52 1	46 1	40 1	34 1	28 1
22 1	16 1	62 1	56 1	50 1	44 1	38 1	32 1

fst = 89 Algorithm table : 50 Steps PULSE (WCMW) = 0

67 0	61 0	55 0	49 0	43 0	37 0	31 0	25 0
19 0	65 0	59 0	53 0	47 0	41 0	35 0	29 0
23 0	63 0	57 0	51 0	45 0	39 0	33 0	27 0
21 0	66 0	60 0	54 0	48 0	42 0	36 0	30 0
24 0	18 0	64 0	58 0	52 0	46 0	40 0	34 0
28 0	22 0	62 0	56 0	50 0	44 0	38 0	32 0
26 0	20 0						

fst = 89 Algorithm table : 25 Steps PULSE (WCMW) = 1

66 1	60 1	54 1	48 1	42 1	36 1	30 1	24 1
18 1	64 1	58 1	52 1	46 1	40 1	34 1	28 1
22 1	62 1	56 1	50 1	44 1	38 1	32 1	26 1
20 1							

fst = 90 Algorithm table : 46 Steps PULSE (WCMW) = 0

67 0	61 0	55 0	49 0	43 0	37 0	31 0	25 0
65 0	59 0	53 0	47 0	41 0	35 0	29 0	23 0
63 0	57 0	51 0	45 0	39 0	33 0	27 0	66 0
60 0	54 0	48 0	42 0	36 0	30 0	24 0	64 0
58 0	52 0	46 0	40 0	34 0	28 0	22 0	62 0
56 0	50 0	44 0	38 0	32 0	26 0		

fst = 90 Algorithm table : 23 Steps PULSE (WCMW) = 1

66 1	60 1	54 1	48 1	42 1	36 1	30 1	24 1
64 1	58 1	52 1	46 1	40 1	34 1	28 1	22 1
62 1	56 1	50 1	44 1	38 1	32 1	26 1	

fst = 91 Algorithm table : 42 Steps PULSE (WCMW) = 0

67 0	61 0	55 0	49 0	43 0	37 0	31 0	65 0
59 0	53 0	47 0	41 0	35 0	29 0	63 0	57 0
51 0	45 0	39 0	33 0	27 0	66 0	60 0	54 0
48 0	42 0	36 0	30 0	64 0	58 0	52 0	46 0
40 0	34 0	28 0	62 0	56 0	50 0	44 0	38 0
32 0	26 0						

fst = 91 Algorithm table : 21 Steps PULSE (WCMW) = 1

66 1	60 1	54 1	48 1	42 1	36 1	30 1	64 1
58 1	52 1	46 1	40 1	34 1	28 1	62 1	56 1
50 1	44 1	38 1	32 1	26 1			

fst = 92 Fixed-table = 22 : 46 Steps PULSE (WCMW) = 0 or 1

79 1	71 1	63 1	55 1	47 1	39 1	31 1	23 1
77 1	69 1	61 1	53 1	45 1	37 1	29 1	21 1
75 1	67 1	59 1	51 1	43 1	35 1	27 1	19 1
73 1	65 1	57 1	49 1	41 1	33 1	25 1	17 0
13 0	9 0	5 0	15 0	11 0	7 0	18 0	14 0
10 0	6 0	16 0	12 0	8 0	4 0		

fst = 93 Fixed-table = 23 : 59 Steps PULSE (WCMW) = 0 or 1

81 1	77 1	73 1	69 1	65 1	61 1	57 1	53 1
49 1	45 1	79 1	75 1	71 1	67 1	63 1	59 1
55 1	51 1	47 1	43 1	39 0	35 0	31 0	27 0
23 0	19 0	15 0	11 0	7 0	41 0	37 0	33 0
29 0	25 0	21 0	17 0	13 0	9 0	5 0	42 0
38 0	34 0	30 0	26 0	22 0	18 0	14 0	10 0
6 0	40 0	36 0	32 0	28 0	24 0	20 0	16 0
12 0	8 0	4 0					

fst = 94 Fixed-table = 24 : 34 Steps PULSE (WCMW) = 0 or 1

51 1	47 1	43 1	39 1	35 1	31 1	27 1	23 1
49 1	45 1	41 1	37 1	33 1	29 1	25 1	21 0
17 0	13 0	9 0	5 0	19 0	15 0	11 0	7 0
22 0	18 0	14 0	10 0	6 0	20 0	16 0	12 0
8 0	4 0						

fst = 95 Algorithm table : 26 Steps PULSE (WCMW) = 0

67 0	61 0	55 0	49 0	43 0	65 0	59 0	53 0
47 0	63 0	57 0	51 0	45 0	66 0	60 0	54 0
48 0	42 0	64 0	58 0	52 0	46 0	62 0	56 0
50 0	44 0						

fst = 95 Algorithm table : 13 Steps PULSE (WCMW) = 1

66 1	60 1	54 1	48 1	42 1	64 1	58 1	52 1
46 1	62 1	56 1	50 1	44 1			

fst = 96 Algorithm table : 72 Steps PULSE (WCMW) = 0

75 0	69 0	63 0	57 0	51 0	45 0	39 0	33 0
27 0	21 0	15 0	9 0	73 0	67 0	61 0	55 0
49 0	43 0	37 0	31 0	25 0	19 0	13 0	7 0
71 0	65 0	59 0	53 0	47 0	41 0	35 0	29 0
23 0	17 0	11 0	5 0	74 0	68 0	62 0	56 0
50 0	44 0	38 0	32 0	26 0	20 0	14 0	8 0
72 0	66 0	60 0	54 0	48 0	42 0	36 0	30 0
24 0	18 0	12 0	6 0	70 0	64 0	58 0	52 0
46 0	40 0	34 0	28 0	22 0	16 0	10 0	4 0

fst = 96 Algorithm table : 36 Steps PULSE (WCMW) = 1

74 1	68 1	62 1	56 1	50 1	44 1	38 1	32 1
26 1	20 1	14 1	8 1	72 1	66 1	60 1	54 1
48 1	42 1	36 1	30 1	24 1	18 1	12 1	6 1
70 1	64 1	58 1	52 1	46 1	40 1	34 1	28 1
22 1	16 1	10 1	4 1				

fst = 97 Algorithm table : 71 Steps PULSE (WCMW) = 0

75 0	69 0	63 0	57 0	51 0	45 0	39 0	33 0
27 0	21 0	15 0	9 0	73 0	67 0	61 0	55 0
49 0	43 0	37 0	31 0	25 0	19 0	13 0	7 0
71 0	65 0	59 0	53 0	47 0	41 0	35 0	29 0
23 0	17 0	11 0	5 0	74 0	68 0	62 0	56 0
50 0	44 0	38 0	32 0	26 0	20 0	14 0	8 0
72 0	66 0	60 0	54 0	48 0	42 0	36 0	30 0
24 0	18 0	12 0	6 0	70 0	64 0	58 0	52 0
46 0	40 0	34 0	28 0	22 0	16 0	10 0	

fst = 97 Algorithm table : 36 Steps PULSE (WCMW) = 1

75 1	69 1	63 1	57 1	51 1	45 1	39 1	33 1
27 1	21 1	15 1	9 1	73 1	67 1	61 1	55 1
49 1	43 1	37 1	31 1	25 1	19 1	13 1	7 1
71 1	65 1	59 1	53 1	47 1	41 1	35 1	29 1
23 1	17 1	11 1	5 1				

fst = 98 Algorithm table : 70 Steps PULSE (WCMW) = 0

75 0	69 0	63 0	57 0	51 0	45 0	39 0	33 0
27 0	21 0	15 0	9 0	73 0	67 0	61 0	55 0
49 0	43 0	37 0	31 0	25 0	19 0	13 0	7 0
71 0	65 0	59 0	53 0	47 0	41 0	35 0	29 0
23 0	17 0	11 0	74 0	68 0	62 0	56 0	50 0
44 0	38 0	32 0	26 0	20 0	14 0	8 0	72 0
66 0	60 0	54 0	48 0	42 0	36 0	30 0	24 0
18 0	12 0	6 0	70 0	64 0	58 0	52 0	46 0
40 0	34 0	28 0	22 0	16 0	10 0		

fst = 98 Algorithm table : 35 Steps PULSE (WCMW) = 1

74 1	68 1	62 1	56 1	50 1	44 1	38 1	32 1
26 1	20 1	14 1	8 1	72 1	66 1	60 1	54 1
48 1	42 1	36 1	30 1	24 1	18 1	12 1	6 1
70 1	64 1	58 1	52 1	46 1	40 1	34 1	28 1
22 1	16 1	10 1					

fst = 99 Algorithm table : 69 Steps PULSE (WCMW) = 0

75 0	69 0	63 0	57 0	51 0	45 0	39 0	33 0
27 0	21 0	15 0	9 0	73 0	67 0	61 0	55 0
49 0	43 0	37 0	31 0	25 0	19 0	13 0	7 0
71 0	65 0	59 0	53 0	47 0	41 0	35 0	29 0
23 0	17 0	11 0	74 0	68 0	62 0	56 0	50 0
44 0	38 0	32 0	26 0	20 0	14 0	8 0	72 0
66 0	60 0	54 0	48 0	42 0	36 0	30 0	24 0
18 0	12 0	70 0	64 0	58 0	52 0	46 0	40 0
34 0	28 0	22 0	16 0	10 0			

fst = 99 Algorithm table : 35 Steps PULSE (WCMW) = 1

75 1	69 1	63 1	57 1	51 1	45 1	39 1	33 1
27 1	21 1	15 1	9 1	73 1	67 1	61 1	55 1
49 1	43 1	37 1	31 1	25 1	19 1	13 1	7 1

71 1 65 1 59 1 53 1 47 1 41 1 35 1 29 1
23 1 17 1 11 1

fst = 100 Algorithm table : 68 Steps PULSE (WCMW) = 0

75 0	69 0	63 0	57 0	51 0	45 0	39 0	33 0
27 0	21 0	15 0	9 0	73 0	67 0	61 0	55 0
49 0	43 0	37 0	31 0	25 0	19 0	13 0	71 0
65 0	59 0	53 0	47 0	41 0	35 0	29 0	23 0
17 0	11 0	74 0	68 0	62 0	56 0	50 0	44 0
38 0	32 0	26 0	20 0	14 0	8 0	72 0	66 0
60 0	54 0	48 0	42 0	36 0	30 0	24 0	18 0
12 0	70 0	64 0	58 0	52 0	46 0	40 0	34 0
28 0	22 0	16 0	10 0				

fst = 100 Algorithm table : 34 Steps PULSE (WCMW) = 1

74 1	68 1	62 1	56 1	50 1	44 1	38 1	32 1
26 1	20 1	14 1	8 1	72 1	66 1	60 1	54 1
48 1	42 1	36 1	30 1	24 1	18 1	12 1	70 1
64 1	58 1	52 1	46 1	40 1	34 1	28 1	22 1
16 1	10 1						

fst = 101 Algorithm table : 66 Steps PULSE (WCMW) = 0

75 0	69 0	63 0	57 0	51 0	45 0	39 0	33 0
27 0	21 0	15 0	73 0	67 0	61 0	55 0	49 0
43 0	37 0	31 0	25 0	19 0	13 0	71 0	65 0
59 0	53 0	47 0	41 0	35 0	29 0	23 0	17 0
11 0	74 0	68 0	62 0	56 0	50 0	44 0	38 0
32 0	26 0	20 0	14 0	72 0	66 0	60 0	54 0
48 0	42 0	36 0	30 0	24 0	18 0	12 0	70 0
64 0	58 0	52 0	46 0	40 0	34 0	28 0	22 0
16 0	10 0						

fst = 101 Algorithm table : 33 Steps PULSE (WCMW) = 1

74 1	68 1	62 1	56 1	50 1	44 1	38 1	32 1
26 1	20 1	14 1	72 1	66 1	60 1	54 1	48 1
42 1	36 1	30 1	24 1	18 1	12 1	70 1	64 1
58 1	52 1	46 1	40 1	34 1	28 1	22 1	16 1
10 1							

fst = 102 Algorithm table : 64 Steps PULSE (WCMW) = 0

75 0	69 0	63 0	57 0	51 0	45 0	39 0	33 0
27 0	21 0	15 0	73 0	67 0	61 0	55 0	49 0
43 0	37 0	31 0	25 0	19 0	13 0	71 0	65 0
59 0	53 0	47 0	41 0	35 0	29 0	23 0	17 0
74 0	68 0	62 0	56 0	50 0	44 0	38 0	32 0
26 0	20 0	14 0	72 0	66 0	60 0	54 0	48 0
42 0	36 0	30 0	24 0	18 0	12 0	70 0	64 0
58 0	52 0	46 0	40 0	34 0	28 0	22 0	16 0

fst = 102 Algorithm table : 32 Steps PULSE (WCMW) = 1

74 1	68 1	62 1	56 1	50 1	44 1	38 1	32 1
26 1	20 1	14 1	72 1	66 1	60 1	54 1	48 1
42 1	36 1	30 1	24 1	18 1	12 1	70 1	64 1
58 1	52 1	46 1	40 1	34 1	28 1	22 1	16 1

fst = 103 Fixed table = 25 : 80 Steps PULSE (WCMW) = 0 or 1

83 0	79 0	75 0	71 0	67 0	63 0	59 0	55 0
51 0	47 0	43 0	39 0	35 0	31 0	27 0	23 0
19 0	15 0	11 0	7 0	81 0	77 0	73 0	69 0
65 0	61 0	57 0	53 0	49 0	45 0	41 0	37 0
33 0	29 0	25 0	21 0	17 0	13 0	9 0	5 0
82 0	78 0	74 0	70 0	66 0	62 0	58 0	54 0
50 0	46 0	42 0	38 0	34 0	30 0	26 0	22 0
18 0	14 0	10 0	6 0	80 0	76 0	72 0	68 0
64 0	60 0	56 0	52 0	48 0	44 0	40 0	36 0
32 0	28 0	24 0	20 0	16 0	12 0	8 0	4 0

fst = 104 Fixed table = 26 : 78 Steps PULSE (WCMW) = 0 or 1

81 0	77 0	73 0	69 0	65 0	61 0	57 0	53 0
49 0	45 0	41 0	37 0	33 0	29 0	25 0	21 0
17 0	13 0	9 0	5 0	79 0	75 0	71 0	67 0
63 0	59 0	55 0	51 0	47 0	43 0	39 0	35 0
31 0	27 0	23 0	19 0	15 0	11 0	7 0	80 0
76 0	72 0	68 0	64 0	60 0	56 0	52 0	48 0
44 0	40 0	36 0	32 0	28 0	24 0	20 0	16 0
12 0	8 0	4 0	78 0	74 0	70 0	66 0	62 0
58 0	54 0	50 0	46 0	42 0	38 0	34 0	30 0
26 0	22 0	18 0	14 0	10 0	6 0		

fst = 105 Fixed table = 27 : 76 Steps PULSE (WCMW) = 0 or 1

79 0	75 0	71 0	67 0	63 0	59 0	55 0	51 0
47 0	43 0	39 0	35 0	31 0	27 0	23 0	19 0
15 0	11 0	7 0	77 0	73 0	69 0	65 0	61 0
57 0	53 0	49 0	45 0	41 0	37 0	33 0	29 0
25 0	21 0	17 0	13 0	9 0	5 0	78 0	74 0
70 0	66 0	62 0	58 0	54 0	50 0	46 0	42 0
38 0	34 0	30 0	26 0	22 0	18 0	14 0	10 0
6 0	76 0	72 0	68 0	64 0	60 0	56 0	52 0
48 0	44 0	40 0	36 0	32 0	28 0	24 0	20 0
16 0	12 0	8 0	4 0				

fst = 106 Fixed table = 28 : 74 Steps PULSE (WCMW) = 0 or 1

77 0	73 0	69 0	65 0	61 0	57 0	53 0	49 0
45 0	41 0	37 0	33 0	29 0	25 0	21 0	17 0
13 0	9 0	5 0	75 0	71 0	67 0	63 0	59 0
55 0	51 0	47 0	43 0	39 0	35 0	31 0	27 0
23 0	19 0	15 0	11 0	7 0	76 0	72 0	68 0
64 0	60 0	56 0	52 0	48 0	44 0	40 0	36 0
32 0	28 0	24 0	20 0	16 0	12 0	8 0	4 0
74 0	70 0	66 0	62 0	58 0	54 0	50 0	46 0
42 0	38 0	34 0	30 0	26 0	22 0	18 0	14 0
10 0	6 0						

fst = 107 Fixed table = 29 : 72 Steps PULSE (WCMW) = 0 or 1

75 0	71 0	67 0	63 0	59 0	55 0	51 0	47 0
43 0	39 0	35 0	31 0	27 0	23 0	19 0	15 0
11 0	7 0	73 0	69 0	65 0	61 0	57 0	53 0
49 0	45 0	41 0	37 0	33 0	29 0	25 0	21 0
17 0	13 0	9 0	5 0	74 0	70 0	66 0	62 0
58 0	54 0	50 0	46 0	42 0	38 0	34 0	30 0
26 0	22 0	18 0	14 0	10 0	6 0	72 0	68 0
64 0	60 0	56 0	52 0	48 0	44 0	40 0	36 0
32 0	28 0	24 0	20 0	16 0	12 0	8 0	4 0

fst = 108 Fixed table = 30 : 80 Steps PULSE (WCMW) = 0 or 1

83 0	81 0	79 0	77 0	75 0	73 0	71 0	69 0
67 0	65 0	63 0	61 0	59 0	57 0	55 0	53 0
51 0	49 0	47 0	45 0	43 0	41 0	39 0	37 0
35 0	33 0	31 0	29 0	27 0	25 0	23 0	21 0
19 0	17 0	15 0	13 0	11 0	9 0	7 0	5 0
82 0	80 0	78 0	76 0	74 0	72 0	70 0	68 0
66 0	64 0	62 0	60 0	58 0	56 0	54 0	52 0
50 0	48 0	46 0	44 0	42 0	40 0	38 0	36 0
34 0	32 0	30 0	28 0	26 0	24 0	22 0	20 0
18 0	16 0	14 0	12 0	10 0	8 0	6 0	4 0

fst = 109 Fixed table = 31 : 76 Steps PULSE (WCMW) = 0 or 1

79 0	77 0	75 0	73 0	71 0	69 0	67 0	65 0
63 0	61 0	59 0	57 0	55 0	53 0	51 0	49 0
47 0	45 0	43 0	41 0	39 0	37 0	35 0	33 0
31 0	29 0	27 0	25 0	23 0	21 0	19 0	17 0
15 0	13 0	11 0	9 0	7 0	5 0	78 0	76 0
74 0	72 0	70 0	68 0	66 0	64 0	62 0	60 0
58 0	56 0	54 0	52 0	50 0	48 0	46 0	44 0
42 0	40 0	38 0	36 0	34 0	32 0	30 0	28 0
26 0	24 0	22 0	20 0	18 0	16 0	14 0	12 0
10 0	8 0	6 0	4 0				

fst = 110 Fixed table = 32 : 72 Steps PULSE (WCMW) = 0 or 1

75 0	73 0	71 0	69 0	67 0	65 0	63 0	61 0
59 0	57 0	55 0	53 0	51 0	49 0	47 0	45 0
43 0	41 0	39 0	37 0	35 0	33 0	31 0	29 0
27 0	25 0	23 0	21 0	19 0	17 0	15 0	13 0
11 0	9 0	7 0	5 0	74 0	72 0	70 0	68 0
66 0	64 0	62 0	60 0	58 0	56 0	54 0	52 0
50 0	48 0	46 0	44 0	42 0	40 0	38 0	36 0
34 0	32 0	30 0	28 0	26 0	24 0	22 0	20 0
18 0	16 0	14 0	12 0	10 0	8 0	6 0	4 0

fst = 111 Fixed table = 33 : 68 Steps PULSE (WCMW) = 0 or 1

71 0	69 0	67 0	65 0	63 0	61 0	59 0	57 0
55 0	53 0	51 0	49 0	47 0	45 0	43 0	41 0
39 0	37 0	35 0	33 0	31 0	29 0	27 0	25 0
23 0	21 0	19 0	17 0	15 0	13 0	11 0	9 0
7 0	5 0	70 0	68 0	66 0	64 0	62 0	60 0
58 0	56 0	54 0	52 0	50 0	48 0	46 0	44 0
42 0	40 0	38 0	36 0	34 0	32 0	30 0	28 0
26 0	24 0	22 0	20 0	18 0	16 0	14 0	12 0
10 0	8 0	6 0	4 0				

fst = 112 Algorithm table : 80 Steps PULSE (WCMW) = 0

83 0	77 0	71 0	65 0	59 0	53 0	47 0	41 0
35 0	29 0	23 0	17 0	11 0	5 0	81 0	75 0
69 0	63 0	57 0	51 0	45 0	39 0	33 0	27 0
21 0	15 0	9 0	79 0	73 0	67 0	61 0	55 0
49 0	43 0	37 0	31 0	25 0	19 0	13 0	7 0
82 0	76 0	70 0	64 0	58 0	52 0	46 0	40 0
34 0	28 0	22 0	16 0	10 0	4 0	80 0	74 0
68 0	62 0	56 0	50 0	44 0	38 0	32 0	26 0
20 0	14 0	8 0	78 0	72 0	66 0	60 0	54 0
48 0	42 0	36 0	30 0	24 0	18 0	12 0	6 0

fst = 112 Algorithm table : 40 Steps PULSE (WCMW) = 1

82 1	76 1	70 1	64 1	58 1	52 1	46 1	40 1
34 1	28 1	22 1	16 1	10 1	4 1	80 1	74 1
68 1	62 1	56 1	50 1	44 1	38 1	32 1	26 1
20 1	14 1	8 1	78 1	72 1	66 1	60 1	54 1
48 1	42 1	36 1	30 1	24 1	18 1	12 1	6 1

fst = 113 Algorithm table : 79 Steps PULSE (WCMW) = 0

83 0	77 0	71 0	65 0	59 0	53 0	47 0	41 0
35 0	29 0	23 0	17 0	11 0	5 0	81 0	75 0
69 0	63 0	57 0	51 0	45 0	39 0	33 0	27 0
21 0	15 0	9 0	79 0	73 0	67 0	61 0	55 0
49 0	43 0	37 0	31 0	25 0	19 0	13 0	7 0
82 0	76 0	70 0	64 0	58 0	52 0	46 0	40 0
34 0	28 0	22 0	16 0	10 0	80 0	74 0	68 0
62 0	56 0	50 0	44 0	38 0	32 0	26 0	20 0
14 0	8 0	78 0	72 0	66 0	60 0	54 0	48 0
42 0	36 0	30 0	24 0	18 0	12 0	6 0	

fst = 113 Algorithm table : 40 Steps PULSE (WCMW) = 1

83 1	77 1	71 1	65 1	59 1	53 1	47 1	41 1
35 1	29 1	23 1	17 1	11 1	5 1	81 1	75 1
69 1	63 1	57 1	51 1	45 1	39 1	33 1	27 1
21 1	15 1	9 1	79 1	73 1	67 1	61 1	55 1
49 1	43 1	37 1	31 1	25 1	19 1	13 1	7 1

fst = 114 Algorithm table : 78 Steps PULSE (WCMW) = 0

83 0	77 0	71 0	65 0	59 0	53 0	47 0	41 0
35 0	29 0	23 0	17 0	11 0	81 0	75 0	69 0
63 0	57 0	51 0	45 0	39 0	33 0	27 0	21 0
15 0	9 0	79 0	73 0	67 0	61 0	55 0	49 0
43 0	37 0	31 0	25 0	19 0	13 0	7 0	82 0
76 0	70 0	64 0	58 0	52 0	46 0	40 0	34 0
28 0	22 0	16 0	10 0	80 0	74 0	68 0	62 0
56 0	50 0	44 0	38 0	32 0	26 0	20 0	14 0
8 0	78 0	72 0	66 0	60 0	54 0	48 0	42 0
36 0	30 0	24 0	18 0	12 0	6 0		

fst = 114 Algorithm table : 39 Steps PULSE (WCMW) = 1

82 1	76 1	70 1	64 1	58 1	52 1	46 1	40 1
34 1	28 1	22 1	16 1	10 1	80 1	74 1	68 1
62 1	56 1	50 1	44 1	38 1	32 1	26 1	20 1
14 1	8 1	78 1	72 1	66 1	60 1	54 1	48 1
42 1	36 1	30 1	24 1	18 1	12 1	6 1	

fst = 115 Algorithm table : 77 Steps PULSE (WCMW) = 0

83 0	77 0	71 0	65 0	59 0	53 0	47 0	41 0
35 0	29 0	23 0	17 0	11 0	81 0	75 0	69 0
63 0	57 0	51 0	45 0	39 0	33 0	27 0	21 0
15 0	9 0	79 0	73 0	67 0	61 0	55 0	49 0
43 0	37 0	31 0	25 0	19 0	13 0	7 0	82 0
76 0	70 0	64 0	58 0	52 0	46 0	40 0	34 0
28 0	22 0	16 0	10 0	80 0	74 0	68 0	62 0
56 0	50 0	44 0	38 0	32 0	26 0	20 0	14 0
8 0	78 0	72 0	66 0	60 0	54 0	48 0	42 0
36 0	30 0	24 0	18 0	12 0			

fst = 115 Algorithm table : 39 Steps PULSE (WCMW) = 1

83 1	77 1	71 1	65 1	59 1	53 1	47 1	41 1
35 1	29 1	23 1	17 1	11 1	81 1	75 1	69 1
63 1	57 1	51 1	45 1	39 1	33 1	27 1	21 1
15 1	9 1	79 1	73 1	67 1	61 1	55 1	49 1
43 1	37 1	31 1	25 1	19 1	13 1	7 1	

fst = 116 Algorithm table : 76 Steps PULSE (WCMW) = 0

83 0	77 0	71 0	65 0	59 0	53 0	47 0	41 0
35 0	29 0	23 0	17 0	11 0	81 0	75 0	69 0
63 0	57 0	51 0	45 0	39 0	33 0	27 0	21 0
15 0	9 0	79 0	73 0	67 0	61 0	55 0	49 0
43 0	37 0	31 0	25 0	19 0	13 0	82 0	76 0
70 0	64 0	58 0	52 0	46 0	40 0	34 0	28 0
22 0	16 0	10 0	80 0	74 0	68 0	62 0	56 0
50 0	44 0	38 0	32 0	26 0	20 0	14 0	8 0
78 0	72 0	66 0	60 0	54 0	48 0	42 0	36 0
30 0	24 0	18 0	12 0				

fst = 116 Algorithm table : 38 Steps PULSE (WCMW) = 1

82 1	76 1	70 1	64 1	58 1	52 1	46 1	40 1
34 1	28 1	22 1	16 1	10 1	80 1	74 1	68 1
62 1	56 1	50 1	44 1	38 1	32 1	26 1	20 1
14 1	8 1	78 1	72 1	66 1	60 1	54 1	48 1
42 1	36 1	30 1	24 1	18 1	12 1		

fst = 117 Algorithm table : 74 Steps PULSE (WCMW) = 0

83 0	77 0	71 0	65 0	59 0	53 0	47 0	41 0
35 0	29 0	23 0	17 0	11 0	81 0	75 0	69 0
63 0	57 0	51 0	45 0	39 0	33 0	27 0	21 0
15 0	79 0	73 0	67 0	61 0	55 0	49 0	43 0
37 0	31 0	25 0	19 0	13 0	82 0	76 0	70 0
64 0	58 0	52 0	46 0	40 0	34 0	28 0	22 0
16 0	10 0	80 0	74 0	68 0	62 0	56 0	50 0
44 0	38 0	32 0	26 0	20 0	14 0	78 0	72 0
66 0	60 0	54 0	48 0	42 0	36 0	30 0	24 0
18 0	12 0						

fst = 117 Algorithm table : 37 Steps PULSE (WCMW) = 1

82 1	76 1	70 1	64 1	58 1	52 1	46 1	40 1
34 1	28 1	22 1	16 1	10 1	80 1	74 1	68 1
62 1	56 1	50 1	44 1	38 1	32 1	26 1	20 1
14 1	78 1	72 1	66 1	60 1	54 1	48 1	42 1
36 1	30 1	24 1	18 1	12 1			

fst = 118 Algorithm table : 72 Steps PULSE (WCMW) = 0

83 0	77 0	71 0	65 0	59 0	53 0	47 0	41 0
35 0	29 0	23 0	17 0	81 0	75 0	69 0	63 0
57 0	51 0	45 0	39 0	33 0	27 0	21 0	15 0
79 0	73 0	67 0	61 0	55 0	49 0	43 0	37 0
31 0	25 0	19 0	13 0	82 0	76 0	70 0	64 0
58 0	52 0	46 0	40 0	34 0	28 0	22 0	16 0
80 0	74 0	68 0	62 0	56 0	50 0	44 0	38 0
32 0	26 0	20 0	14 0	78 0	72 0	66 0	60 0
54 0	48 0	42 0	36 0	30 0	24 0	18 0	12 0

fst = 118 Algorithm table : 36 Steps PULSE (WCMW) = 1

82 1	76 1	70 1	64 1	58 1	52 1	46 1	40 1
34 1	28 1	22 1	16 1	80 1	74 1	68 1	62 1
56 1	50 1	44 1	38 1	32 1	26 1	20 1	14 1
78 1	72 1	66 1	60 1	54 1	48 1	42 1	36 1
30 1	24 1	18 1	12 1				

fst = 119 Fixed table = 34 : 79 Steps PULSE (WCMW) = 0 or 1

82 0	76 0	70 0	64 0	58 0	52 0	46 0	40 0
34 0	28 0	22 0	16 0	10 0	4 0	80 0	74 0
68 0	62 0	56 0	50 0	44 0	38 0	32 0	26 0
20 0	14 0	8 0	78 0	72 0	66 0	60 0	54 0
48 0	42 0	36 0	30 0	24 0	18 0	12 0	6 0
81 0	75 0	69 0	63 0	57 0	51 0	45 0	39 0
33 0	27 0	21 0	15 0	9 0	79 0	73 0	67 0
61 0	55 0	49 0	43 0	37 0	31 0	25 0	19 0
13 0	7 0	77 0	71 0	65 0	59 0	53 0	47 0
41 0	35 0	29 0	23 0	17 0	11 0	5 0	

fst = 120 Fixed table = 35 : 77 Steps PULSE (WCMW) = 0 or 1

80 0	74 0	68 0	62 0	56 0	50 0	44 0	38 0
32 0	26 0	20 0	14 0	8 0	78 0	72 0	66 0
60 0	54 0	48 0	42 0	36 0	30 0	24 0	18 0
12 0	6 0	76 0	70 0	64 0	58 0	52 0	46 0
40 0	34 0	28 0	22 0	16 0	10 0	4 0	79 0
73 0	67 0	61 0	55 0	49 0	43 0	37 0	31 0
25 0	19 0	13 0	7 0	77 0	71 0	65 0	59 0
53 0	47 0	41 0	35 0	29 0	23 0	17 0	11 0
5 0	75 0	69 0	63 0	57 0	51 0	45 0	39 0
33 0	27 0	21 0	15 0	9 0			

fst = 121 Fixed table = 36 : 75 Steps PULSE (WCMW) = 0 or 1

78 0	72 0	66 0	60 0	54 0	48 0	42 0	36 0
30 0	24 0	18 0	12 0	6 0	76 0	70 0	64 0
58 0	52 0	46 0	40 0	34 0	28 0	22 0	16 0
10 0	4 0	74 0	68 0	62 0	56 0	50 0	44 0
38 0	32 0	26 0	20 0	14 0	8 0	77 0	71 0
65 0	59 0	53 0	47 0	41 0	35 0	29 0	23 0
17 0	11 0	5 0	75 0	69 0	63 0	57 0	51 0
45 0	39 0	33 0	27 0	21 0	15 0	9 0	73 0
67 0	61 0	55 0	49 0	43 0	37 0	31 0	25 0
19 0	13 0	7 0					

fst = 122 Fixed table = 37 : 73 Steps PULSE (WCMW) = 0 or 1

76 0	70 0	64 0	58 0	52 0	46 0	40 0	34 0
28 0	22 0	16 0	10 0	4 0	74 0	68 0	62 0
56 0	50 0	44 0	38 0	32 0	26 0	20 0	14 0
8 0	72 0	66 0	60 0	54 0	48 0	42 0	36 0
30 0	24 0	18 0	12 0	6 0	75 0	69 0	63 0
57 0	51 0	45 0	39 0	33 0	27 0	21 0	15 0
9 0	73 0	67 0	61 0	55 0	49 0	43 0	37 0
31 0	25 0	19 0	13 0	7 0	71 0	65 0	59 0
53 0	47 0	41 0	35 0	29 0	23 0	17 0	11 0
5 0							

fst = 123 Fixed table = 38 : 71 Steps PULSE (WCMW) = 0 or 1

74 0	68 0	62 0	56 0	50 0	44 0	38 0	32 0
26 0	20 0	14 0	8 0	72 0	66 0	60 0	54 0
48 0	42 0	36 0	30 0	24 0	18 0	12 0	6 0
70 0	64 0	58 0	52 0	46 0	40 0	34 0	28 0
22 0	16 0	10 0	4 0	73 0	67 0	61 0	55 0
49 0	43 0	37 0	31 0	25 0	19 0	13 0	7 0
71 0	65 0	59 0	53 0	47 0	41 0	35 0	29 0
23 0	17 0	11 0	5 0	69 0	63 0	57 0	51 0
45 0	39 0	33 0	27 0	21 0	15 0	9 0	

fst = 124 Fixed table = 39 : 69 Steps PULSE (WCMW) = 0 or 1

72 0	66 0	60 0	54 0	48 0	42 0	36 0	30 0
24 0	18 0	12 0	6 0	70 0	64 0	58 0	52 0
46 0	40 0	34 0	28 0	22 0	16 0	10 0	4 0
68 0	62 0	56 0	50 0	44 0	38 0	32 0	26 0
20 0	14 0	8 0	71 0	65 0	59 0	53 0	47 0
41 0	35 0	29 0	23 0	17 0	11 0	5 0	69 0
63 0	57 0	51 0	45 0	39 0	33 0	27 0	21 0
15 0	9 0	67 0	61 0	55 0	49 0	43 0	37 0
31 0	25 0	19 0	13 0	7 0			

fst = 125 Fixed table = 40 : 67 Steps PULSE (WCMW) = 0 or 1

70 0	64 0	58 0	52 0	46 0	40 0	34 0	28 0
22 0	16 0	10 0	4 0	68 0	62 0	56 0	50 0
44 0	38 0	32 0	26 0	20 0	14 0	8 0	66 0
60 0	54 0	48 0	42 0	36 0	30 0	24 0	18 0
12 0	6 0	69 0	63 0	57 0	51 0	45 0	39 0
33 0	27 0	21 0	15 0	9 0	67 0	61 0	55 0
49 0	43 0	37 0	31 0	25 0	19 0	13 0	7 0
65 0	59 0	53 0	47 0	41 0	35 0	29 0	23 0
17 0	11 0	5 0					

fst = 126 Fixed table = 41 : 65 Steps PULSE (WCMW) = 0 or 1

68 0	62 0	56 0	50 0	44 0	38 0	32 0	26 0
20 0	14 0	8 0	66 0	60 0	54 0	48 0	42 0
36 0	30 0	24 0	18 0	12 0	6 0	64 0	58 0
52 0	46 0	40 0	34 0	28 0	22 0	16 0	10 0
4 0	67 0	61 0	55 0	49 0	43 0	37 0	31 0
25 0	19 0	13 0	7 0	65 0	59 0	53 0	47 0
41 0	35 0	29 0	23 0	17 0	11 0	5 0	63 0
57 0	51 0	45 0	39 0	33 0	27 0	21 0	15 0
9 0							

fst = 127 Fixed table = 42 : 63 Steps PULSE (WCMW) = 0 or 1

66 0	60 0	54 0	48 0	42 0	36 0	30 0	24 0
18 0	12 0	6 0	64 0	58 0	52 0	46 0	40 0
34 0	28 0	22 0	16 0	10 0	4 0	62 0	56 0
50 0	44 0	38 0	32 0	26 0	20 0	14 0	8 0
65 0	59 0	53 0	47 0	41 0	35 0	29 0	23 0
17 0	11 0	5 0	63 0	57 0	51 0	45 0	39 0
33 0	27 0	21 0	15 0	9 0	61 0	55 0	49 0
43 0	37 0	31 0	25 0	19 0	13 0	7 0	

V WHISPER internal tables and mapping

V-1 Windowing Coefficients Table (Blackman-Harris) 16 bit.

$$w(n) = a_0 - a_1 \cos(2\pi n/N) + a_2 \cos(4\pi n/N)$$

with $a_0 = 0.42323$, $a_1 = 0.49755$, $a_2 = 0.00792$

Add Val	Add Val	Add Val	Add Val	Add Val
0 = a0	48 = 1a9	96 = 519	144 = bca	192 =16a1
1 = a0	49 = 1b4	97 = 534	145 = bf9	193 =16e7
2 = a1	50 = 1c0	98 = 54e	146 = c28	194 =172e
3 = a1	51 = 1cc	99 = 569	147 = c57	195 =1775
4 = a2	52 = 1d8	100 = 585	148 = c86	196 =17bd
5 = a3	53 = 1e5	101 = 5a1	149 = cb7	197 =1805
6 = a4	54 = 1f1	102 = 5bd	150 = ce7	198 =184e
7 = a6	55 = 1ff	103 = 5d9	151 = d19	199 =1897
8 = a7	56 = 20c	104 = 5f6	152 = d4a	200 =18e1
9 = a9	57 = 219	105 = 613	153 = d7c	201 =192b
10 = ab	58 = 227	106 = 631	154 = daf	202 =1975
11 = ae	59 = 236	107 = 64f	155 = de2	203 =19c1
12 = b0	60 = 244	108 = 66e	156 = e15	204 =1a0c
13 = b3	61 = 253	109 = 68c	157 = e49	205 =1a59
14 = b6	62 = 262	110 = 6ac	158 = e7e	206 =1aa6
15 = b9	63 = 271	111 = 6cb	159 = eb3	207 =1af3
16 = bd	64 = 281	112 = 6eb	160 = ee9	208 =1b41
17 = c0	65 = 291	113 = 70c	161 = f1f	209 =1b8f
18 = c4	66 = 2a1	114 = 72d	162 = f55	210 =1bde
19 = c8	67 = 2b1	115 = 74e	163 = f8c	211 =1c2d
20 = cd	68 = 2c2	116 = 76f	164 = fc3	212 =1c7d
21 = d1	69 = 2d3	117 = 791	165 =ffb	213 =1ccd
22 = d6	70 = 2e5	118 = 7b4	166 =1034	214 =1d1e
23 = db	71 = 2f6	119 = 7d7	167 =106d	215 =1d6f
24 = e1	72 = 308	120 = 7fa	168 =10a6	216 =1dc1
25 = e6	73 = 31b	121 = 81e	169 =10e0	217 =1e13
26 = ec	74 = 32d	122 = 842	170 =111b	218 =1e66
27 = f2	75 = 340	123 = 866	171 =1156	219 =1eb9
28 = f8	76 = 353	124 = 88b	172 =1191	220 =1f0d
29 = ff	77 = 367	125 = 8b1	173 =11cd	221 =1f61
30 = 106	78 = 37b	126 = 8d6	174 =120a	222 =1fb6
31 = 10d	79 = 38f	127 = 8fd	175 =1247	223 =200b
32 = 114	80 = 3a3	128 = 923	176 =1284	224 =2061
33 = 11b	81 = 3b8	129 = 94a	177 =12c2	225 =20b7
34 = 123	82 = 3cd	130 = 972	178 =1301	226 =210d
35 = 12b	83 = 3e3	131 = 99a	179 =1340	227 =2165
36 = 133	84 = 3f9	132 = 9c2	180 =137f	228 =21bc
37 = 13b	85 = 40f	133 = 9eb	181 =13bf	229 =2214
38 = 144	86 = 425	134 = a15	182 =1400	230 =226d
39 = 14d	87 = 43c	135 = a3e	183 =1441	231 =22c6
40 = 156	88 = 453	136 = a68	184 =1482	232 =231f
41 = 160	89 = 46b	137 = a93	185 =14c4	233 =2379
42 = 169	90 = 483	138 = abe	186 =1507	234 =23d4
43 = 173	91 = 49b	139 = aea	187 =154a	235 =242e
44 = 17d	92 = 4b3	140 = b16	188 =158e	236 =248a
45 = 188	93 = 4cc	141 = b42	189 =15d2	237 =24e6
46 = 192	94 = 4e6	142 = b6f	190 =1616	238 =2542
47 = 19d	95 = 4ff	143 = b9d	191 =165b	239 =259e

Add Val	Add Val	Add Val	Add Val	Add Val
240 =25fc	293 =3b64	346 =5305	399 =6901	452 =791a
241 =2659	294 =3bd4	347 =5376	400 =6960	453 =7953
242 =26b7	295 =3c44	348 =53e8	401 =69bf	454 =798b
243 =2716	296 =3cb4	349 =5459	402 =6a1d	455 =79c2
244 =2774	297 =3d24	350 =54ca	403 =6a7a	456 =79f8
245 =27d4	298 =3d94	351 =553b	404 =6ad7	457 =7a2e
246 =2833	299 =3e05	352 =55ac	405 =6b33	458 =7a62
247 =2894	300 =3e75	353 =561c	406 =6b8f	459 =7a96
248 =28f4	301 =3ee6	354 =568d	407 =6be9	460 =7ac9
249 =2955	302 =3f57	355 =56fd	408 =6c44	461 =7afb
250 =29b7	303 =3fc8	356 =576d	409 =6c9e	462 =7b2c
251 =2a18	304 =403a	357 =57dc	410 =6cf7	463 =7b5c
252 =2a7b	305 =40ab	358 =584c	411 =6d4f	464 =7b8b
253 =2add	306 =411d	359 =58bb	412 =6da7	465 =7bb9
254 =2b40	307 =418f	360 =592a	413 =6dff	466 =7be7
255 =2ba4	308 =4201	361 =5998	414 =6e55	467 =7c13
256 =2c08	309 =4273	362 =5a07	415 =6eab	468 =7c3f
257 =2c6c	310 =42e5	363 =5a75	416 =6f00	469 =7c69
258 =2cd1	311 =4357	364 =5ae3	417 =6f55	470 =7c93
259 =2d36	312 =43c9	365 =5b51	418 =6fa9	471 =7cbc
260 =2d9b	313 =443c	366 =5bbe	419 =6ffd	472 =7ce3
261 =2e01	314 =44ae	367 =5c2b	420 =704f	473 =7d0a
262 =2e67	315 =4521	368 =5c98	421 =70a1	474 =7d30
263 =2ecd	316 =4594	369 =5d04	422 =70f2	475 =7d55
264 =2f34	317 =4606	370 =5d70	423 =7143	476 =7d79
265 =2f9b	318 =4679	371 =5ddc	424 =7193	477 =7d9c
266 =3003	319 =46ec	372 =5e47	425 =71e2	478 =7dbe
267 =306b	320 =475f	373 =5eb3	426 =7230	479 =7ddf
268 =30d3	321 =47d2	374 =5f1d	427 =727e	480 =7e00
269 =313c	322 =4845	375 =5f88	428 =72cb	481 =7e1f
270 =31a5	323 =48b8	376 =5ff2	429 =7317	482 =7e3d
271 =320e	324 =492b	377 =605b	430 =7363	483 =7e5a
272 =3278	325 =499e	378 =60c5	431 =73ae	484 =7e77
273 =32e1	326 =4a11	379 =612d	432 =73f8	485 =7e92
274 =334c	327 =4a84	380 =6196	433 =7441	486 =7eac
275 =33b6	328 =4af7	381 =61fe	434 =748a	487 =7ec6
276 =3421	329 =4b6a	382 =6266	435 =74d1	488 =7ede
277 =348c	330 =4bdd	383 =62cd	436 =7518	489 =7ef6
278 =34f8	331 =4c50	384 =6334	437 =755e	490 =7f0c
279 =3564	332 =4cc3	385 =639a	438 =75a4	491 =7f22
280 =35d0	333 =4d36	386 =6400	439 =75e8	492 =7f36
281 =363c	334 =4da9	387 =6465	440 =762c	493 =7f4a
282 =36a9	335 =4e1c	388 =64ca	441 =766f	494 =7f5c
283 =3715	336 =4e8f	389 =652f	442 =76b1	495 =7f6e
284 =3783	337 =4f01	390 =6593	443 =76f3	496 =7f7e
285 =37f0	338 =4f74	391 =65f7	444 =7733	497 =7f8e
286 =385e	339 =4fe6	392 =665a	445 =7773	498 =7f9c
287 =38cc	340 =5059	393 =66bc	446 =77b2	499 =7faa
288 =393a	341 =50cb	394 =671f	447 =77f0	500 =7fb6
289 =39a8	342 =513d	395 =6780	448 =782d	501 =7fc2
290 =3a17	343 =51af	396 =67e1	449 =786a	502 =7fcc
291 =3a86	344 =5221	397 =6842	450 =78a5	503 =7fd6
292 =3af5	345 =5293	398 =68a2	451 =78e0	504 =7fde

Add	Val	Add	Val	Add	Val	Add	Val	Add	Val
505	=7fe6	558	=7be7	611	=6dff	664	=592a	717	=418f
506	=7fec	559	=7bb9	612	=6da7	665	=58bb	718	=411d
507	=7ff2	560	=7b8b	613	=6d4f	666	=584c	719	=40ab
508	=7ff6	561	=7b5c	614	=6cf7	667	=57dc	720	=403a
509	=7ffa	562	=7b2c	615	=6c9e	668	=576d	721	=3fc8
510	=7ffc	563	=7afb	616	=6c44	669	=56fd	722	=3f57
511	=7ffe	564	=7ac9	617	=6be9	670	=568d	723	=3ee6
512	=7fff	565	=7a96	618	=6b8f	671	=561c	724	=3e75
513	=7ffe	566	=7a62	619	=6b33	672	=55ac	725	=3e05
514	=7ffc	567	=7a2e	620	=6ad7	673	=553b	726	=3d94
515	=7ffa	568	=79f8	621	=6a7a	674	=54ca	727	=3d24
516	=7ff6	569	=79c2	622	=6a1d	675	=5459	728	=3cb4
517	=7ff2	570	=798b	623	=69bf	676	=53e8	729	=3c44
518	=7fec	571	=7953	624	=6960	677	=5376	730	=3bd4
519	=7fe6	572	=791a	625	=6901	678	=5305	731	=3b64
520	=7fde	573	=78e0	626	=68a2	679	=5293	732	=3af5
521	=7fd6	574	=78a5	627	=6842	680	=5221	733	=3a86
522	=7fcc	575	=786a	628	=67e1	681	=51af	734	=3a17
523	=7fc2	576	=782d	629	=6780	682	=513d	735	=39a8
524	=7fb6	577	=77f0	630	=671f	683	=50cb	736	=393a
525	=7faa	578	=77b2	631	=66bc	684	=5059	737	=38cc
526	=7f9c	579	=7773	632	=665a	685	=4fe6	738	=385e
527	=7f8e	580	=7733	633	=65f7	686	=4f74	739	=37f0
528	=7f7e	581	=76f3	634	=6593	687	=4f01	740	=3783
529	=7f6e	582	=76b1	635	=652f	688	=4e8f	741	=3715
530	=7f5c	583	=766f	636	=64ca	689	=4e1c	742	=36a9
531	=7f4a	584	=762c	637	=6465	690	=4da9	743	=363c
532	=7f36	585	=75e8	638	=6400	691	=4d36	744	=35d0
533	=7f22	586	=75a4	639	=639a	692	=4cc3	745	=3564
534	=7f0c	587	=755e	640	=6334	693	=4c50	746	=34f8
535	=7ef6	588	=7518	641	=62cd	694	=4bdd	747	=348c
536	=7ede	589	=74d1	642	=6266	695	=4b6a	748	=3421
537	=7ec6	590	=748a	643	=61fe	696	=4af7	749	=33b6
538	=7eac	591	=7441	644	=6196	697	=4a84	750	=334c
539	=7e92	592	=73f8	645	=612d	698	=4a11	751	=32e1
540	=7e77	593	=73ae	646	=60c5	699	=499e	752	=3278
541	=7e5a	594	=7363	647	=605b	700	=492b	753	=320e
542	=7e3d	595	=7317	648	=5ff2	701	=48b8	754	=31a5
543	=7e1f	596	=72cb	649	=5f88	702	=4845	755	=313c
544	=7e00	597	=727e	650	=5f1d	703	=47d2	756	=30d3
545	=7ddf	598	=7230	651	=5eb3	704	=475f	757	=306b
546	=7dbe	599	=71e2	652	=5e47	705	=46ec	758	=3003
547	=7d9c	600	=7193	653	=5ddc	706	=4679	759	=2f9b
548	=7d79	601	=7143	654	=5d70	707	=4606	760	=2f34
549	=7d55	602	=70f2	655	=5d04	708	=4594	761	=2ecd
550	=7d30	603	=70a1	656	=5c98	709	=4521	762	=2e67
551	=7d0a	604	=704f	657	=5c2b	710	=44ae	763	=2e01
552	=7ce3	605	=6ffd	658	=5bbe	711	=443c	764	=2d9b
553	=7cbc	606	=6fa9	659	=5b51	712	=43c9	765	=2d36
554	=7c93	607	=6f55	660	=5ae3	713	=4357	766	=2cd1
555	=7c69	608	=6f00	661	=5a75	714	=42e5	767	=2c6c
556	=7c3f	609	=6eab	662	=5a07	715	=4273	768	=2c08
557	=7c13	610	=6e55	663	=5998	716	=4201	769	=2ba4

Add Val	Add Val	Add Val	Add Val	Add Val
770 =2b40	823 =192b	876 = c86	929 = 4ff	982 = 169
771 =2add	824 =18e1	877 = c57	930 = 4e6	983 = 160
772 =2a7b	825 =1897	878 = c28	931 = 4cc	984 = 156
773 =2a18	826 =184e	879 = bf9	932 = 4b3	985 = 14d
774 =29b7	827 =1805	880 = bca	933 = 49b	986 = 144
775 =2955	828 =17bd	881 = b9d	934 = 483	987 = 13b
776 =28f4	829 =1775	882 = b6f	935 = 46b	988 = 133
777 =2894	830 =172e	883 = b42	936 = 453	989 = 12b
778 =2833	831 =16e7	884 = b16	937 = 43c	990 = 123
779 =27d4	832 =16a1	885 = aea	938 = 425	991 = 11b
780 =2774	833 =165b	886 = abe	939 = 40f	992 = 114
781 =2716	834 =1616	887 = a93	940 = 3f9	993 = 10d
782 =26b7	835 =15d2	888 = a68	941 = 3e3	994 = 106
783 =2659	836 =158e	889 = a3e	942 = 3cd	995 = ff
784 =25fc	837 =154a	890 = a15	943 = 3b8	996 = f8
785 =259e	838 =1507	891 = 9eb	944 = 3a3	997 = f2
786 =2542	839 =14c4	892 = 9c2	945 = 38f	998 = ec
787 =24e6	840 =1482	893 = 99a	946 = 37b	999 = e6
788 =248a	841 =1441	894 = 972	947 = 367	1000 = e1
789 =242e	842 =1400	895 = 94a	948 = 353	1001 = db
790 =23d4	843 =13bf	896 = 923	949 = 340	1002 = d6
791 =2379	844 =137f	897 = 8fd	950 = 32d	1003 = d1
792 =231f	845 =1340	898 = 8d6	951 = 31b	1004 = cd
793 =22c6	846 =1301	899 = 8b1	952 = 308	1005 = c8
794 =226d	847 =12c2	900 = 88b	953 = 2f6	1006 = c4
795 =2214	848 =1284	901 = 866	954 = 2e5	1007 = c0
796 =21bc	849 =1247	902 = 842	955 = 2d3	1008 = bd
797 =2165	850 =120a	903 = 81e	956 = 2c2	1009 = b9
798 =210d	851 =11cd	904 = 7fa	957 = 2b1	1010 = b6
799 =20b7	852 =1191	905 = 7d7	958 = 2a1	1011 = b3
800 =2061	853 =1156	906 = 7b4	959 = 291	1012 = b0
801 =200b	854 =111b	907 = 791	960 = 281	1013 = ae
802 =1fb6	855 =10e0	908 = 76f	961 = 271	1014 = ab
803 =1f61	856 =10a6	909 = 74e	962 = 262	1015 = a9
804 =1f0d	857 =106d	910 = 72d	963 = 253	1016 = a7
805 =1eb9	858 =1034	911 = 70c	964 = 244	1017 = a6
806 =1e66	859 = ffb	912 = 6eb	965 = 236	1018 = a4
807 =1e13	860 = fc3	913 = 6cb	966 = 227	1019 = a3
808 =1dc1	861 = f8c	914 = 6ac	967 = 219	1020 = a2
809 =1d6f	862 = f55	915 = 68c	968 = 20c	1021 = a1
810 =1d1e	863 = f1f	916 = 66e	969 = 1ff	1022 = a1
811 =1ccd	864 = ee9	917 = 64f	970 = 1f1	1023 = a0
812 =1c7d	865 = eb3	918 = 631	971 = 1e5	
813 =1c2d	866 = e7e	919 = 613	972 = 1d8	
814 =1bde	867 = e49	920 = 5f6	973 = 1cc	
815 =1b8f	868 = e15	921 = 5d9	974 = 1c0	
816 =1b41	869 = de2	922 = 5bd	975 = 1b4	
817 =1af3	870 = daf	923 = 5a1	976 = 1a9	
818 =1aa6	871 = d7c	924 = 585	977 = 19d	
819 =1a59	872 = d4a	925 = 569	978 = 192	
820 =1a0c	873 = d19	926 = 54e	979 = 188	
821 =19c1	874 = ce7	927 = 534	980 = 17d	
822 =1975	875 = cb7	928 = 519	981 = 173	

V-2 Synthesizer Prom table

Add Val	Add Val	Add Val	Add Val	Add Val
0 = 7f	50 = c9	100 = f7	150 = fa	200 = d0
1 = 81	51 = ca	101 = f8	151 = f9	201 = cf
2 = 83	52 = cb	102 = f8	152 = f9	202 = ce
3 = 84	53 = cc	103 = f9	153 = f9	203 = cc
4 = 86	54 = ce	104 = f9	154 = f8	204 = cb
5 = 87	55 = cf	105 = f9	155 = f8	205 = ca
6 = 89	56 = d0	106 = fa	156 = f7	206 = c9
7 = 8a	57 = d1	107 = fa	157 = f7	207 = c7
8 = 8c	58 = d2	108 = fb	158 = f6	208 = c6
9 = 8d	59 = d4	109 = fb	159 = f5	209 = c5
10 = 8f	60 = d5	110 = fb	160 = f5	210 = c3
11 = 91	61 = d6	111 = fc	161 = f4	211 = c2
12 = 92	62 = d7	112 = fc	162 = f4	212 = c1
13 = 94	63 = d8	113 = fc	163 = f3	213 = bf
14 = 95	64 = d9	114 = fd	164 = f2	214 = be
15 = 97	65 = da	115 = fd	165 = f2	215 = bd
16 = 98	66 = db	116 = fd	166 = f1	216 = bb
17 = 9a	67 = dd	117 = fd	167 = f0	217 = ba
18 = 9b	68 = de	118 = fe	168 = f0	218 = b9
19 = 9d	69 = df	119 = fe	169 = ef	219 = b7
20 = 9e	70 = e0	120 = fe	170 = ee	220 = b6
21 = a0	71 = e1	121 = fe	171 = ed	221 = b4
22 = a1	72 = e2	122 = fe	172 = ec	222 = b3
23 = a3	73 = e3	123 = fe	173 = ec	223 = b2
24 = a4	74 = e4	124 = fe	174 = eb	224 = b0
25 = a6	75 = e5	125 = fe	175 = ea	225 = af
26 = a7	76 = e6	126 = fe	176 = e9	226 = ad
27 = a9	77 = e6	127 = fe	177 = e8	227 = ac
28 = aa	78 = e7	128 = ff	178 = e7	228 = aa
29 = ac	79 = e8	129 = fe	179 = e6	229 = a9
30 = ad	80 = e9	130 = fe	180 = e6	230 = a7
31 = af	81 = ea	131 = fe	181 = e5	231 = a6
32 = b0	82 = eb	132 = fe	182 = e4	232 = a4
33 = b2	83 = ec	133 = fe	183 = e3	233 = a3
34 = b3	84 = ec	134 = fe	184 = e2	234 = a1
35 = b4	85 = ed	135 = fe	185 = e1	235 = a0
36 = b6	86 = ee	136 = fe	186 = e0	236 = 9e
37 = b7	87 = ef	137 = fe	187 = df	237 = 9d
38 = b9	88 = f0	138 = fe	188 = de	238 = 9b
39 = ba	89 = f0	139 = fd	189 = dd	239 = 9a
40 = bb	90 = f1	140 = fd	190 = db	240 = 98
41 = bd	91 = f2	141 = fd	191 = da	241 = 97
42 = be	92 = f2	142 = fd	192 = d9	242 = 95
43 = bf	93 = f3	143 = fc	193 = d8	243 = 94
44 = c1	94 = f4	144 = fc	194 = d7	244 = 92
45 = c2	95 = f4	145 = fc	195 = d6	245 = 91
46 = c3	96 = f5	146 = fb	196 = d5	246 = 8f
47 = c5	97 = f5	147 = fb	197 = d4	247 = 8d
48 = c6	98 = f6	148 = fb	198 = d2	248 = 8c
49 = c7	99 = f7	149 = fa	199 = d1	249 = 8a

Add Val	Add Val	Add Val	Add Val	Add Val
250 = 89	303 = 39	356 = 07	409 = 05	462 = 35
251 = 87	304 = 38	357 = 06	410 = 06	463 = 37
252 = 86	305 = 37	358 = 06	411 = 06	464 = 38
253 = 84	306 = 35	359 = 05	412 = 07	465 = 39
254 = 83	307 = 34	360 = 05	413 = 07	466 = 3b
255 = 81	308 = 33	361 = 05	414 = 08	467 = 3c
256 = 7f	309 = 32	362 = 04	415 = 09	468 = 3d
257 = 7d	310 = 30	363 = 04	416 = 09	469 = 3f
258 = 7b	311 = 2f	364 = 03	417 = 0a	470 = 40
259 = 7a	312 = 2e	365 = 03	418 = 0a	471 = 41
260 = 78	313 = 2d	366 = 03	419 = 0b	472 = 43
261 = 77	314 = 2c	367 = 02	420 = 0c	473 = 44
262 = 75	315 = 2a	368 = 02	421 = 0c	474 = 45
263 = 74	316 = 29	369 = 02	422 = 0d	475 = 47
264 = 72	317 = 28	370 = 01	423 = 0e	476 = 48
265 = 71	318 = 27	371 = 01	424 = 0e	477 = 4a
266 = 6f	319 = 26	372 = 01	425 = 0f	478 = 4b
267 = 6d	320 = 25	373 = 01	426 = 10	479 = 4c
268 = 6c	321 = 24	374 = 00	427 = 11	480 = 4e
269 = 6a	322 = 23	375 = 00	428 = 12	481 = 4f
270 = 69	323 = 21	376 = 00	429 = 12	482 = 51
271 = 67	324 = 20	377 = 00	430 = 13	483 = 52
272 = 66	325 = 1f	378 = 00	431 = 14	484 = 54
273 = 64	326 = 1e	379 = 00	432 = 15	485 = 55
274 = 63	327 = 1d	380 = 00	433 = 16	486 = 57
275 = 61	328 = 1c	381 = 00	434 = 17	487 = 58
276 = 60	329 = 1b	382 = 00	435 = 18	488 = 5a
277 = 5e	330 = 1a	383 = 00	436 = 18	489 = 5b
278 = 5d	331 = 19	384 = 00	437 = 19	490 = 5d
279 = 5b	332 = 18	385 = 00	438 = 1a	491 = 5e
280 = 5a	333 = 18	386 = 00	439 = 1b	492 = 60
281 = 58	334 = 17	387 = 00	440 = 1c	493 = 61
282 = 57	335 = 16	388 = 00	441 = 1d	494 = 63
283 = 55	336 = 15	389 = 00	442 = 1e	495 = 64
284 = 54	337 = 14	390 = 00	443 = 1f	496 = 66
285 = 52	338 = 13	391 = 00	444 = 20	497 = 67
286 = 51	339 = 12	392 = 00	445 = 21	498 = 69
287 = 4f	340 = 12	393 = 00	446 = 23	499 = 6a
288 = 4e	341 = 11	394 = 00	447 = 24	500 = 6c
289 = 4c	342 = 10	395 = 01	448 = 25	501 = 6d
290 = 4b	343 = 0f	396 = 01	449 = 26	502 = 6f
291 = 4a	344 = 0e	397 = 01	450 = 27	503 = 71
292 = 48	345 = 0e	398 = 01	451 = 28	504 = 72
293 = 47	346 = 0d	399 = 02	452 = 29	505 = 74
294 = 45	347 = 0c	400 = 02	453 = 2a	506 = 75
295 = 44	348 = 0c	401 = 02	454 = 2c	507 = 77
296 = 43	349 = 0b	402 = 03	455 = 2d	508 = 78
297 = 41	350 = 0a	403 = 03	456 = 2e	509 = 7a
298 = 40	351 = 0a	404 = 03	457 = 2f	510 = 7b
299 = 3f	352 = 09	405 = 04	458 = 30	511 = 7d
300 = 3d	353 = 09	406 = 04	459 = 32	
301 = 3c	354 = 08	407 = 05	460 = 33	
302 = 3b	355 = 07	408 = 05	461 = 34	

V-3 Micro-Controller mapping

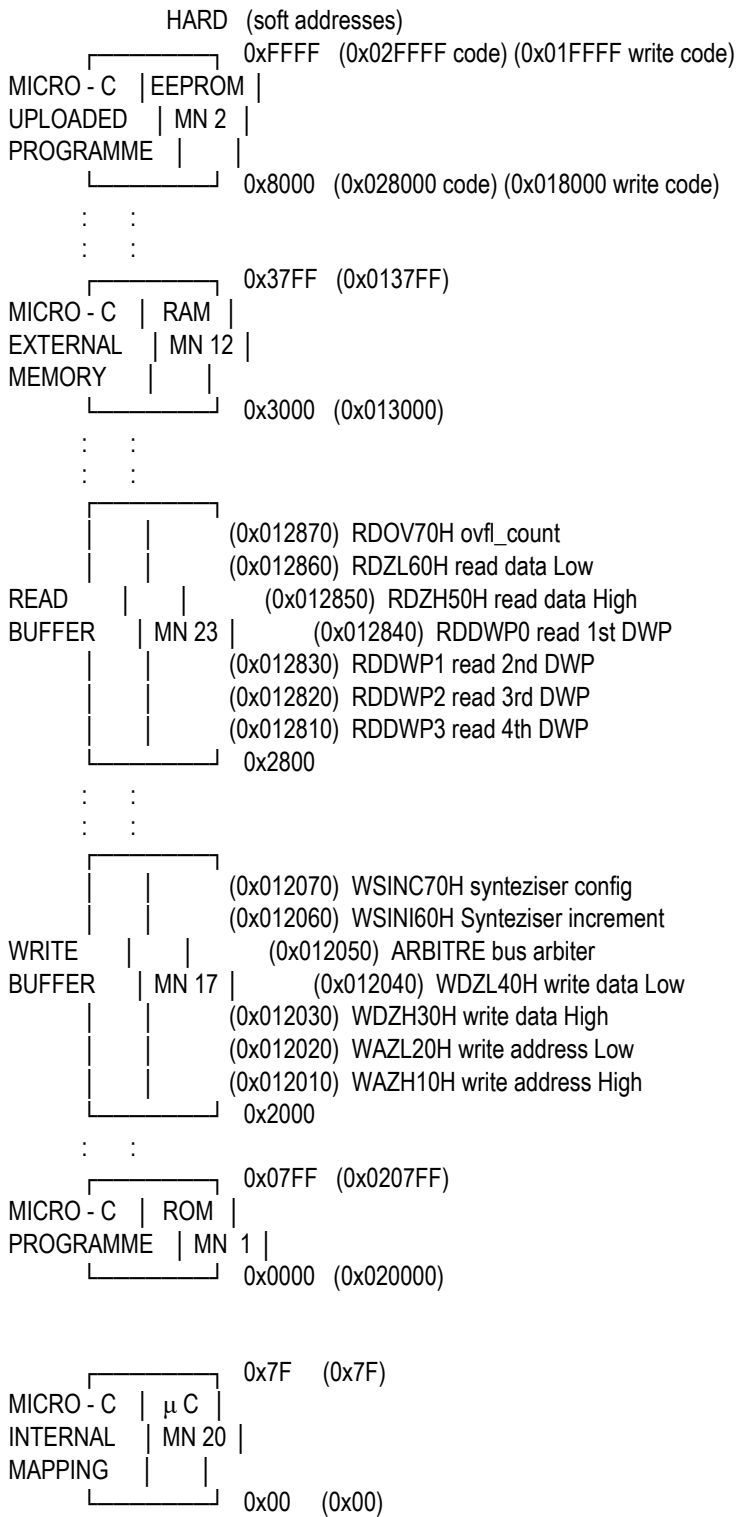

V-5 Micro-Controller BIT addressable register area

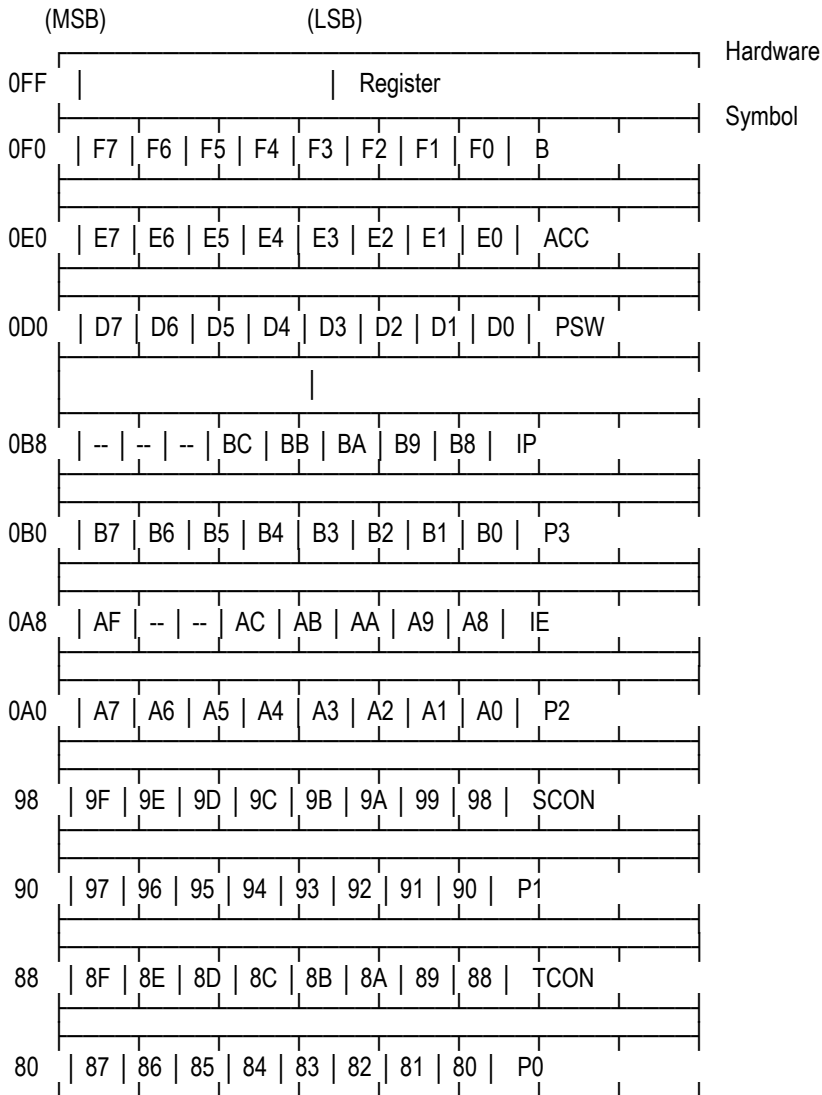

PORT ALLOCATION

P0.0	0x80	bus address Low or DATA
to P0.7	0x87	"
P1.0	0x90	E_SIGNAL
P1.1	0x91	GACQ1
P1.2	0x92	GACQ2
P1.3	0x93	CALM_A
P1.4	0x94	ACQM_A
P1.5	0x95	BLKP_27
P1.6	0x96	FRAMRDY
P1.7	0x97	INTVSP
P2.0	0xA0	bus address high
to P2.7	0xA7	"
P3.0	0xB0	RXD
P3.1	0xB0	TXD
P3.2	0xB2	WHSS external interrupt 0
P3.3	0xB3	BLANKP external interrupt 1
P3.4	0xB4	WORDE timer 0 external input
P3.5	0xB0	T1 timer 1
P3.6	0xB0	WR
P3.7	0xB0	RD

V-6 VSP mapping

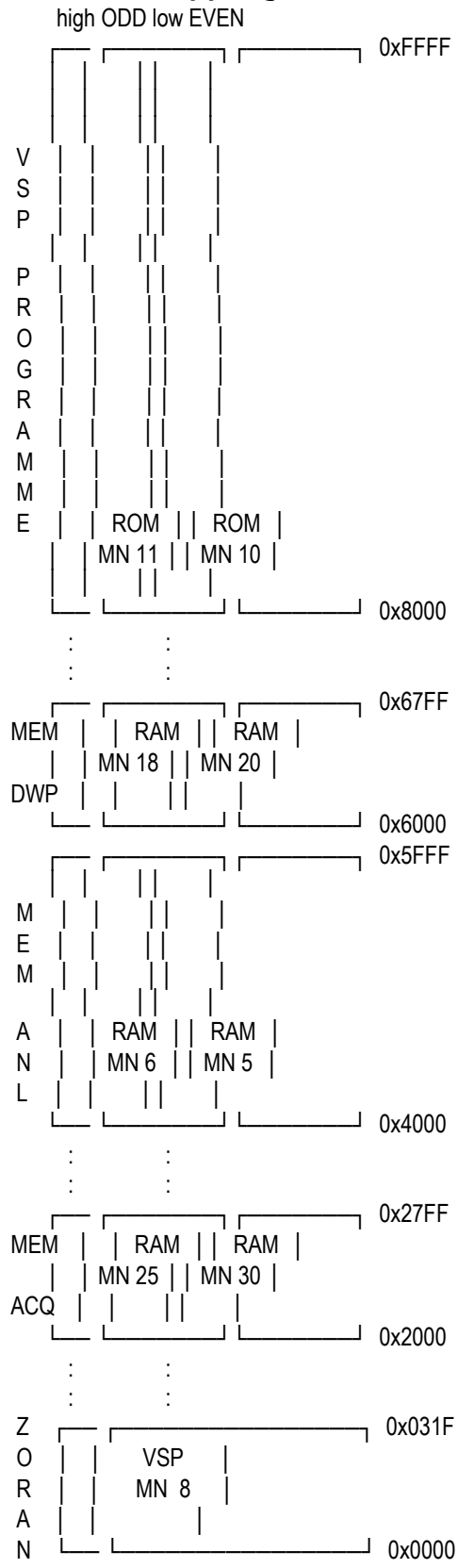

V-7 ZORAN internal memory and register mapping

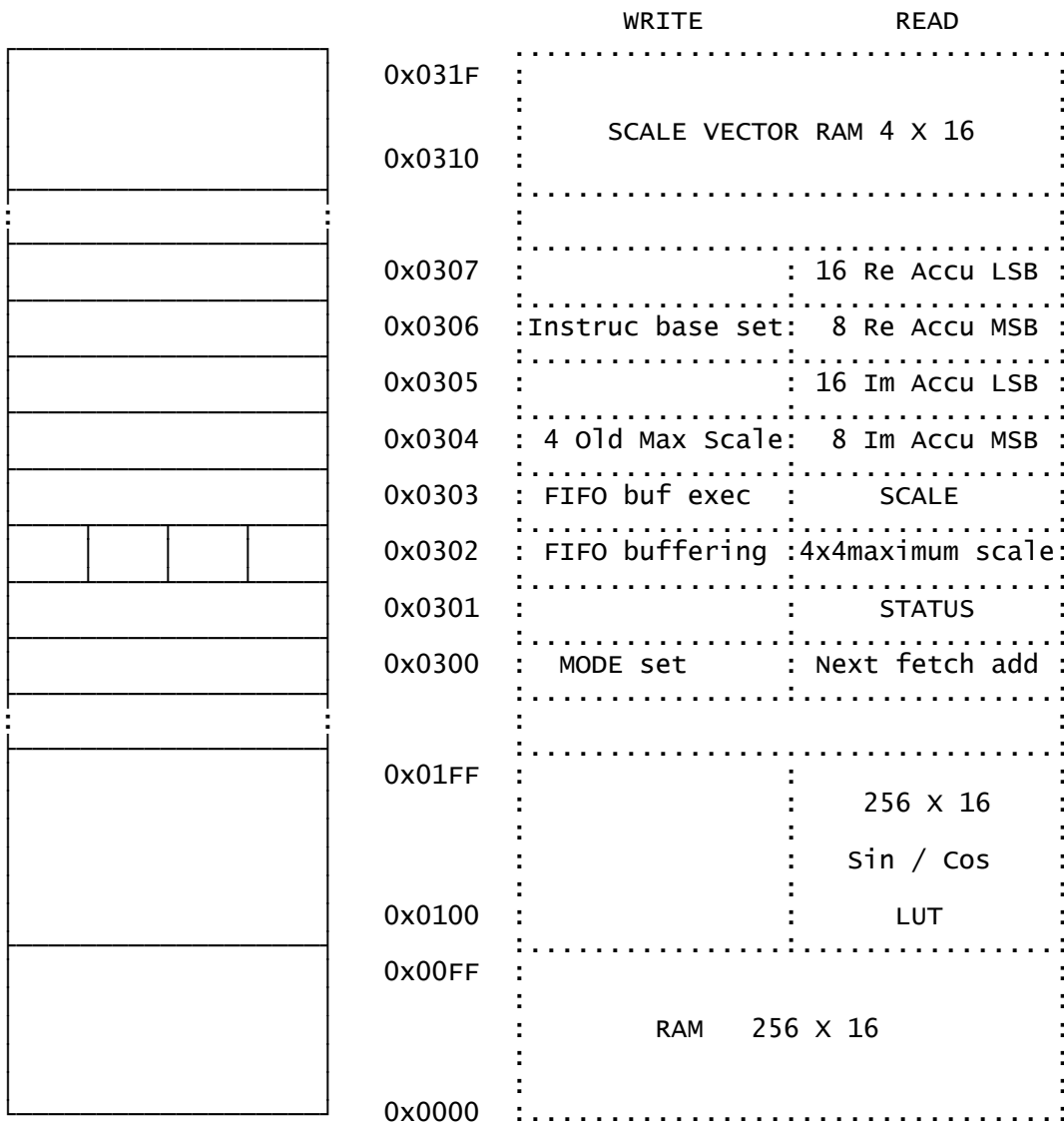

VI Connector pin Assignment

VI.1 J01 Power interface (to WEC 11 - J05, WEC cable N° 03) Connector type : DAM15PNMB

WEC 9.1 J01 pin	Signal description		WEC 11 J05 pin
1	- 6 v		1
2	+ 8 v		2
3	nc	nc	3
4	+ 27 v		4
5	nc (shield of + 27 v grounded at WEC 11)		5
6	nc	nc	6
7	+ 5.5 v	nc	7
8	+ 6 v		8
9	- 6 v return		9
10	+ 8 v return		10
11	nc	nc	11
12	+ 27 v return		12
13	Structure ground	nc	13
14	+ 5.5 v return		14
15	+ 6 v return		15

VI.2 J02 Transmitter data link (to WEC 3 - J02 & WEC 4 - J02, WEC cable N°13.b)

Connector type : DEMA9SNMB

WEC 9.1 J02 pin	Signal description	WEC 3 J02 pin	WEC 4 J02 pin
1	structure ground (sheild)	1	1
2	nc		
3	nc		
4	nc		
5	nc		
6	WHISPER/TX true signal (+ EY boom)	9	
7	WHISPER/TX true return	2	
8	WHISPER/TX Comp signal (- EY boom)		9
9	WHISPER/TX Comp return		2

VI.3 J03 Receiver data link (to WEC 1 - J02 and WEC 2 - J02, WEC cable N° 13.a)

Connector type : DEMA9PNMB

WEC 9.1 J03 pin	Signal description	WEC 1 J02 pin	WEC 2 J02 pin	WEC3 J02 pin	WEC4 J02 pin
1	structure ground	1	1	1	1
2	+ EY return			4	
3	+ EY signal (+ EY boom)			11	
4	- EY return				4
5	- EY signal (- EY boom)				11
6	+ EZ signal (+ EZ boom)	11			
7	+ EZ return	4			
8	- EZ signal (- EZ boom)		11		
9	- EZ return		4		

VI.4 J04 DWP interface (to WEC 9.2 - J09, WEC cable N° 08)
Connector type : DCMA37PNMB

WEC 9.1 J04 pin	Signal description		WEC 11 J09 pin
1	signal ground		1
2	WHTD1		2
3	WHTD3		3
4	WHTD5		4
5	WHTD7		5
6	WHTD9		6
7	WHTD11		7
8	WHTD13		8
9	WHTD15		9
10	WHFrameReady		10
11	WH1mRead		11
12	WHCmdClock		12
13	WHCmdStrobe		13
14	WHReset		14
15	nc	nc	15
16	WHSampleSync		16
17	TempSense3		17
18	nc	nc	18
19	structure ground (sheild)		19
20	WHTD0		20
21	WHTD2		21
22	WHTD4		22
23	WHTD6		23
24	WHTD8		24
25	WHTD10		25
26	WHTD12		26
27	WHTD14		27
28	signal ground		28
29	WHRstCntr		29
30	nc	nc	30
31	WHCmdData		31
32	signal ground		32
33	WHAlarm		33
34	WHblankP		34
35	signal ground		35
36	TempReturn		36
37	nc	nc	37

VI.5 J05 HVC interface and TEST (to HVC panel)
Connector type : DEMA9SNMB

WEC 9.1 J05 pin	Signal description	HVC or panel	disable connector	EEPROM loaded
1	HVC return	X	X	X
2	WDPG/TXD			X
3	RXD			X
4	Write Micro Controller			X
5	HVC	X	X	X
6	nc			
7	signal ground			X
8	Write EEPROM			X
9	nc			

WCMW0		WCMW1		WCMW2		WCMW3		(fst) 00 to 7f (0 to 127) (S & T modes)	
7	6	5	4	3	2	1	0	0B	11
								0A 10 short table 6/3 steps 27/26-22	
								0C 12 fix table 1 40 steps 83-5.5ms 1/2	
								0E 14 fix table 3 52 steps 82-4 mixed	
								2F 47 fix table 8 36 steps 62-8 mixed	
								70 112 full table 80/40 steps 83/82-4	
								Receiver ovfl thres (T,S,N) dump_mem (D mode)	
								Ez default 2 ovfl acq_dump 18 x 64 words	
								Ez 3 ovfl PROM μC 18 x 64 words	
								Ez 5 ovfl EEPROM μC 283 x 64 words	
								Ez 7 ovfl PROM VSP 142 x 64 words	
								Ez 9 ovfl RAM WIN 18 x 64 words	
								Ez 11 ovfl all MEM 461 x 64 words	
								Ez 13 ovfl all MEM 461 x 64 words	
								Ez 15 ovfl all MEM 461 x 64 words	
								Ey default 2 ovfl acq_dump 18 x 64 words	
								Ey 3 ovfl PROM μC 18 x 64 words	
								Ey 5 ovfl PROM VSP 142 x 64 words	
								Ey 7 ovfl RAM WIN 18 x 64 words	
								Ey 9 ovfl all MEM 461 x 64 words	
								Ey 11 ovfl all MEM 461 x 64 words	
								Ey 13 ovfl all MEM 461 x 64 words	
								Ey 15 ovfl all MEM 461 x 64 words	
								(gain_cmd)	
								0_0 fixed gain + 12 dB S, T, N, D (acq_dump)	
								1_1 fixed gain + 24 dB modes	
								2_2 fixed gain + 36 dB	
								3_3 fixed gain + 36 dB	
								4_4 auto gain + 24 / + 12 dB (reserved protect)	
								5_5 auto gain + 24 / + 12 dB S, T & N	
								6_6 auto gain + 36 / + 24 dB modes	
								7_7 auto gain + 36 / + 24 dB only	
								(whi_pro) DWP WHISPER (PULSE) (level)	
								0_0 Yes 0 00 no emission (N & Cal modes)	
								1_0 Yes 0 1.024ms 01 low 50v (S & T modes)	
								2_0 Yes 0 1.024ms 02 medium 100v (S & T modes)	
								3_0 Yes 0 1.024ms 03 high 200v (S & T modes)	
								4_0 Yes 1 00 no emission (N & Cal modes)	
								5_0 Yes 1 0.512ms 01 low 50v (S & T modes)	
								6_0 Yes 1 0.512ms 02 medium 100v (S & T modes)	
								7_0 Yes 1 0.512ms 03 high 200v (S & T modes)	
								8_1 Yes 0 00 no emission (N, T, Cal & D modes)	
								9_1 Yes 0 1.024ms 01 low 50v (S & T modes)	
								A_1 Yes 0 1.024ms 02 medium 100v (S & T modes)	
								B_1 Yes 0 1.024ms 03 high 200v (S & T modes)	
								C_1 Yes 1 00 no emission (N, Cal & D modes)	
								D_1 Yes 1 0.512ms 01 low 50v (S & T modes)	
								E_1 Yes 1 0.512ms 02 medium 100v (S & T modes)	
								F_1 Yes 1 0.512ms 02 high 200v (S & T modes)	
								(smode_aver) S & T modes N mode D & Cal modes	
								0_0 1 E 1 R 32 spectra 0_ only	
								1_1 1 E 2 R 16 spectra A	
								2_2 1 E 3 R 16 spectra L	
								3_3 1 E 5 R 8 spectra N L	
								4_4 1 E 8 R 4 spectra O O	
								5_5 Gliding 40 X 1E1R + 158 + 256R 2 spectra T W	
								6_6 Sync A 1 E 5 R 64 spectra E	
								7_7 Sync B 1 E 13 R 1 spectrum D	
								(fft_size) S,T & N modes Cal mode D mode (rep_fac) S & T modes N mode D,Cal modes	
								0_0 64 bins 64 bins/words 0 1 1 1	
								1_0 64 bins 64 bins/words 1 2 8 1	
								2_0 64 bins 64 bins/words 2 32 232 1	
								3_0 64 bins 64 bins/words 3 128 116 1	
								4_1 128 bins 0 1 1	
								5_1 128 bins N N 1 2 8 N	
								6_1 128 bins O O 2 32 232 O	
								7_1 128 bins T T 3 128 116 T	
								8_2 256 bins 0 1 1	
								9_2 256 bins A A 1 2 8 A	
								A_2 256 bins L L 2 32 232 L	
								B_2 256 bins L L 3 128 116 L	
								C_3 512 bins O O 0 1 1 O	
								D_3 512 bins W W 1 2 8 W	
								E_3 512 bins E E 2 32 232 E	
								F_3 512 bins D D 3 128 116 D	

```

(mode)
| 8_ 0 Contingency 1 (natural waves) Cn mode 80 78 60 00 | protect 90 08 4F 55
| 9_ 1 Tracking (also Upload) T mode Upload 90 08 00 7F --| unprotect 90 08 4F 6F
| A_ 2 Sounding S mode ----- WHI | A(C..F) 0(9..B) xx 0B
| B_ 3 Calibration 2 (sounding) Cals mode | A(C..F) 0(D..F) xx 0C
| C_ 4 Natural waves N mode default CB 13 60 70 -- WHI | C(4..7) 18 xx 00
| D_ 5 Calibration 1 (quiet) Calq mode | C(8..B) 38 xx 00
| E_ 6 Dump (troubleshooting) D mode -----| Do_Nothing E0 08 x0 nn (0<nn<7F)
| F_ 7 Contingency 2 (sounding) Cs mode FC 0A 60 70 | Alarme E0 08 x0 7F

```

VIII Short Form for Data Analysis (EGSE)

WHISPER EGSE SOFTWARE
WHISPER DSD DATA ANALYSIS
Software version 5.0
Ph. Martin February 1998

FUNCTION KEYS USAGE SUMMARY

1 - FILE TEMPLATE RECOVERY AND QUICK LOOK FILE ANALYSIS

For every WHISPER operation modes on both text and graphics information displays :

<F1> Pause on display
<F2> Print screen
<F3> Print all switch ON/OFF (default off)
<F4> Stop current processing and exit to main menu
Sh<F1> Continue current processing (after pause or print)

2 - DATA BLOCK ANALYSIS

2.1 On both text and graphics displays

- For every WHISPER operation modes :

<F1> Pause on display
<F2> Print screen
<F3> Print all switch ON/OFF (default off)
<F4> Stop current processing and exit to main menu
Sh<F1> Continue current processing

- For WHISPER Contingency 1, Tracking, Sounding, Natural waves and Contingency 2 modes data without DWP post-processing, for Calibration (without WHISPER post-processing) and Troubleshooting Acquisition Memory Dump modes data :

<F5> display experiment status
<F6> display FFT data

- For WHISPER Contingency 1 and Natural Waves modes data with DWP post-processing :

<F5> display experiment status set 1
<F6> display experiment status set 2
<F7> display energy data
<F8> display overflow data
<F9> display FFT data

- For WHISPER Sounding and Contingency 2 modes data with DWP post-processing :

<F5> display experiment status set 1
<F6> display experiment status set 2
<F7> display ratio data (if any)
<F8> display passive FFT data (if any)
<F9> display active FFT data

2.2 On graphic displays only

- For WHISPER Contingency 1, Tracking, Sounding, Natural waves and Contingency 2 modes data without DWP post-processing, for Calibration (without WHISPER post-processing) and Troubleshooting Acquisition Memory Dump modes data :

Sh<F5> display FFT data raw values in left window with linear Y scale and activate markers
Sh<F6> display FFT data raw values in right window with log Y scale and activate markers
Sh<F7> display FFT data denormalised values in left window with linear Y scale and activate markers
Sh<F8> display FFT data denormalised values in right window with log Y scale and activate markers

In addition for Acquisition Memory Dump Mode data only :

<F9> improve spectral analysis of Acquisition Memory Dump Mode data

- For WHISPER Contingency 1 and Natural Waves modes data with DWP post-processing,

when displaying energy data :

Sh<F5> display energy data raw values in left window with linear Y scale and activate markers
Sh<F7> display energy data denormalised values in right window with linear Y scale and activate markers

when displaying overflow data :

Sh<F5> display again overflow data values in left window with linear Y scale and activate markers

- For WHISPER Sounding and Contingency 2 modes data with DWP post-processing,

when displaying ratio data :

Sh<F5> display ratio data values in left window with linear Y scale and raw X scale and activate markers
Sh<F7> display ratio data denormalised values in right window with linear Y scale and frequency on the X-axis and activate markers

- For WHISPER Contingency 1, Sounding, Natural waves and Contingency 2 modes data with DWP post-processing,

when displaying the FFT data :

Sh<F5> display FFT data raw values in left window with linear Y scale and activate markers
Sh<F6> display FFT data raw values in right window with log Y scale and activate markers
Sh<F7> display FFT data denormalised values in left window with linear Y scale and activate markers

Sh<F8> display FFT data denormalised values in right window with log Y scale and activate markers

- within an active window identified by two vertical white line markers :

<Left-Arrow> move either or both markers to the left by an amount determined by the <Pg-Up> key
<Right-Arrow> move either or both markers to the right by an amount determined by the <Pg-Up> key
<End> restrict the effect of the right and left arrow keys to the left marker
<Pg-Dn> restrict the effect of the right and left arrow keys to the right marker
<Pg-Up><n> set the increment that the arrow keys move the markers
<Home> display the coordinates of the active marker position
<Ins> zoom the data between the two markers
 deactivate the marker functions