

North 

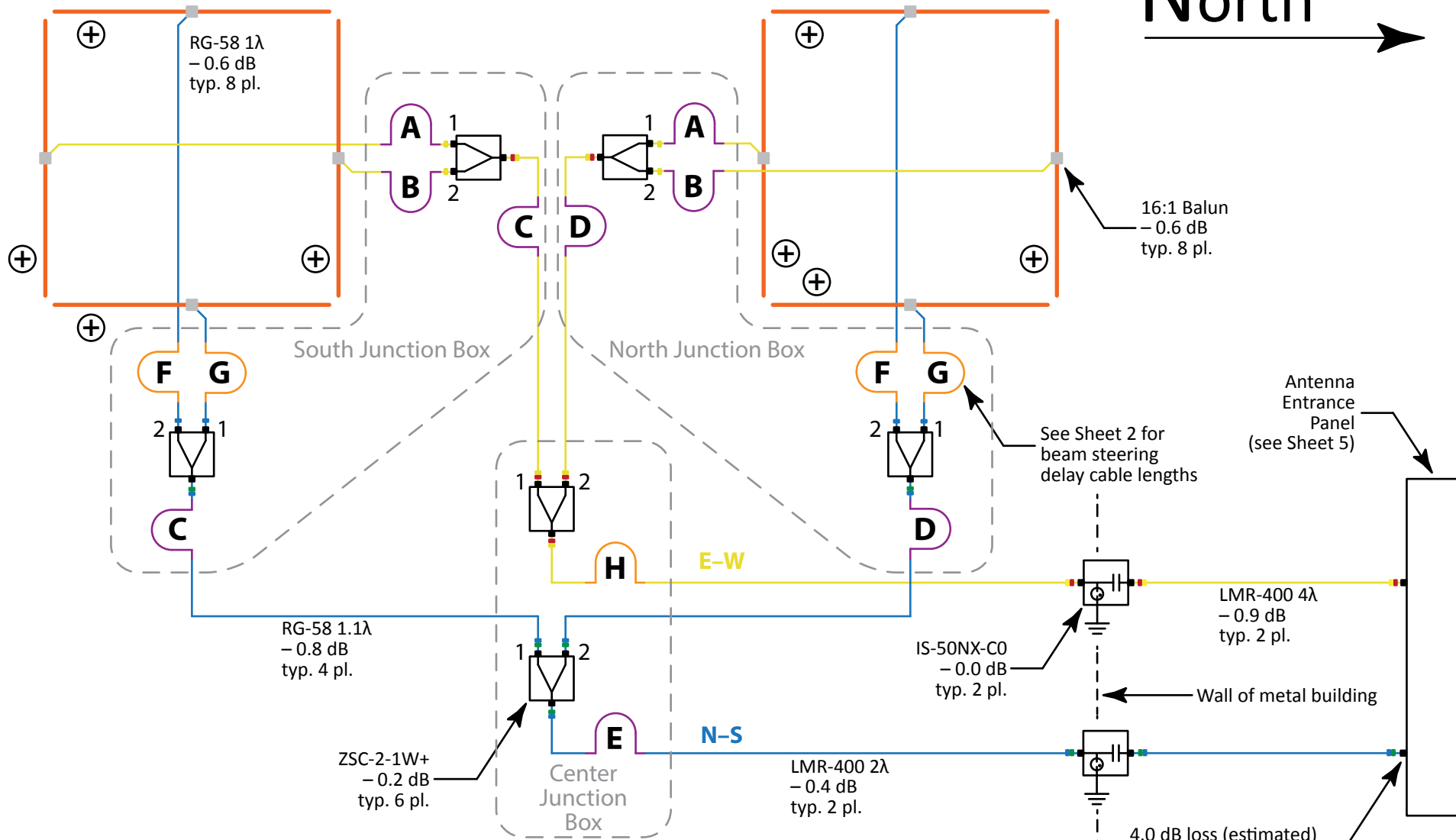

TFD ARRAY CONFIGURATION C CP MODE

See Sheet 5 for XY to CP 90° Hybrid

Noted coax lengths are in terms of wavelength at 20.1 MHz.

30' folded dipoles, top wire 9'2" height,
8" wire spacing, 32' element spacing,
800 Ω termination resistors, 16:1 baluns.

N-S BW ~10° E-W BW ~20°
for < 3 dB response variance at 24 MHz



AJ4CO Observatory Diagram

SIZE	DATE	PART NUMBER	REV
A	15 JAN 2014	N/A	
SCALE	DRAWN BY	SHEET	1 OF 5
NONE	DAVE TYPINSKI		

North →

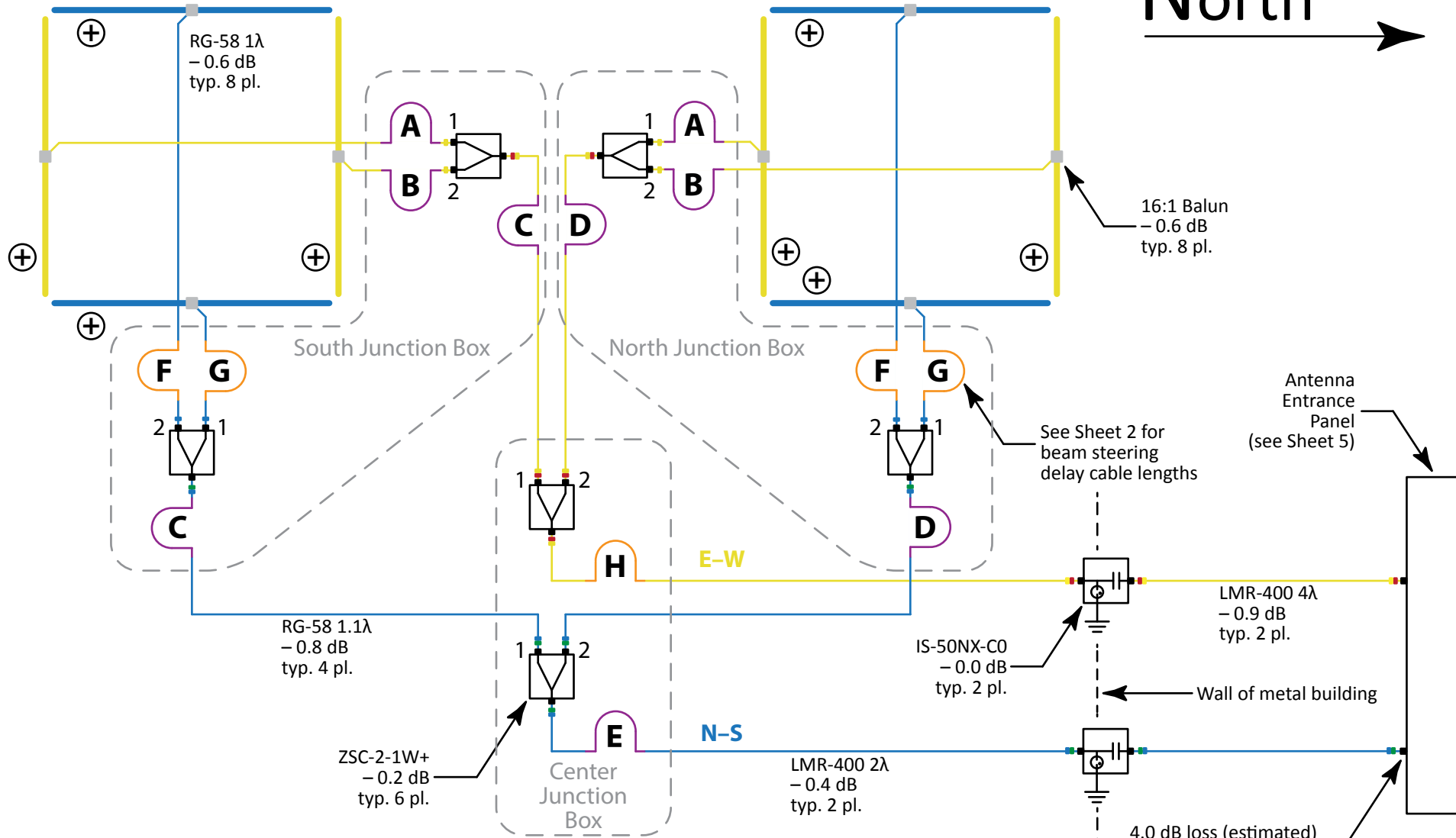

TFD ARRAY CONFIGURATION C CP MODE

See Sheet 5 for XY to CP 90° Hybrid

Noted coax lengths are in terms of wavelength at 20.1 MHz.

30' folded dipoles, top wire 9'2" height, 8" wire spacing, 32' element spacing, 800 Ω termination resistors, 16:1 baluns.

N-S BW ~10° E-W BW ~20°
for < 3 dB response variance at 24 MHz

		<h2>AJ4CO Observatory Diagram</h2>		
		SIZE A	DATE 15 JAN 2014	PART NUMBER N/A
SCALE NONE	DRAWN BY DAVE TYPINSKI	SHEET 1 OF 5		

North 

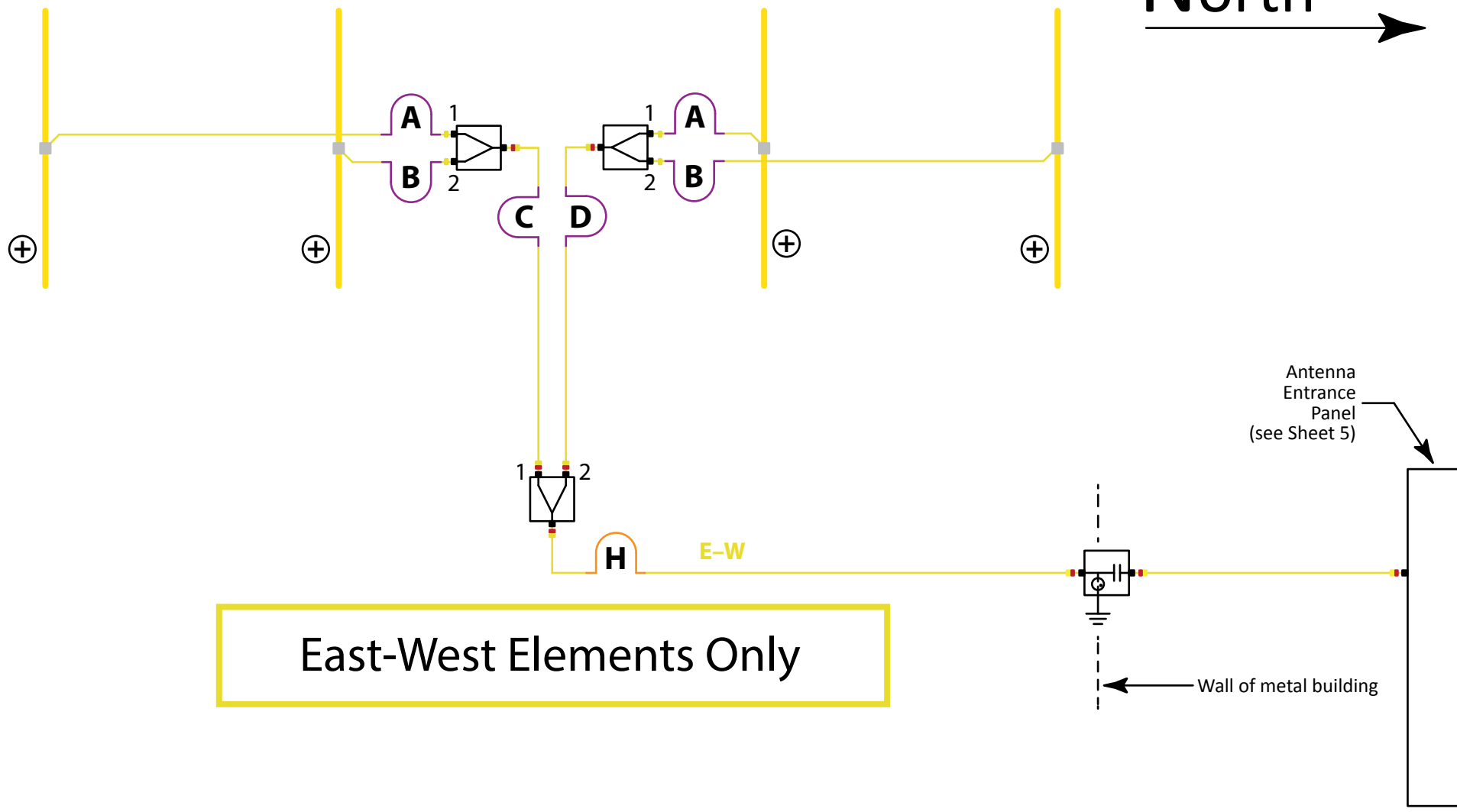

East-West Elements Only

Antenna Entrance Panel
(see Sheet 5)

Wall of metal building

TFD ARRAY CONFIGURATION C CP MODE

See Sheet 5 for XY to CP 90° Hybrid

Noted coax lengths are in terms of wavelength at 20.1 MHz.

30' folded dipoles, top wire 9'2" height,
8" wire spacing, 32' element spacing,
800 Ω termination resistors, 16:1 baluns.

N-S BW ~10° E-W BW ~20°
for < 3 dB response variance at 24 MHz



AJ4CO Observatory Diagram

SIZE A	DATE 15 JAN 2014	PART NUMBER N/A	REV
SCALE NONE	DRAWN BY DAVE TYPINSKI	SHEET 1 OF 5	

North →

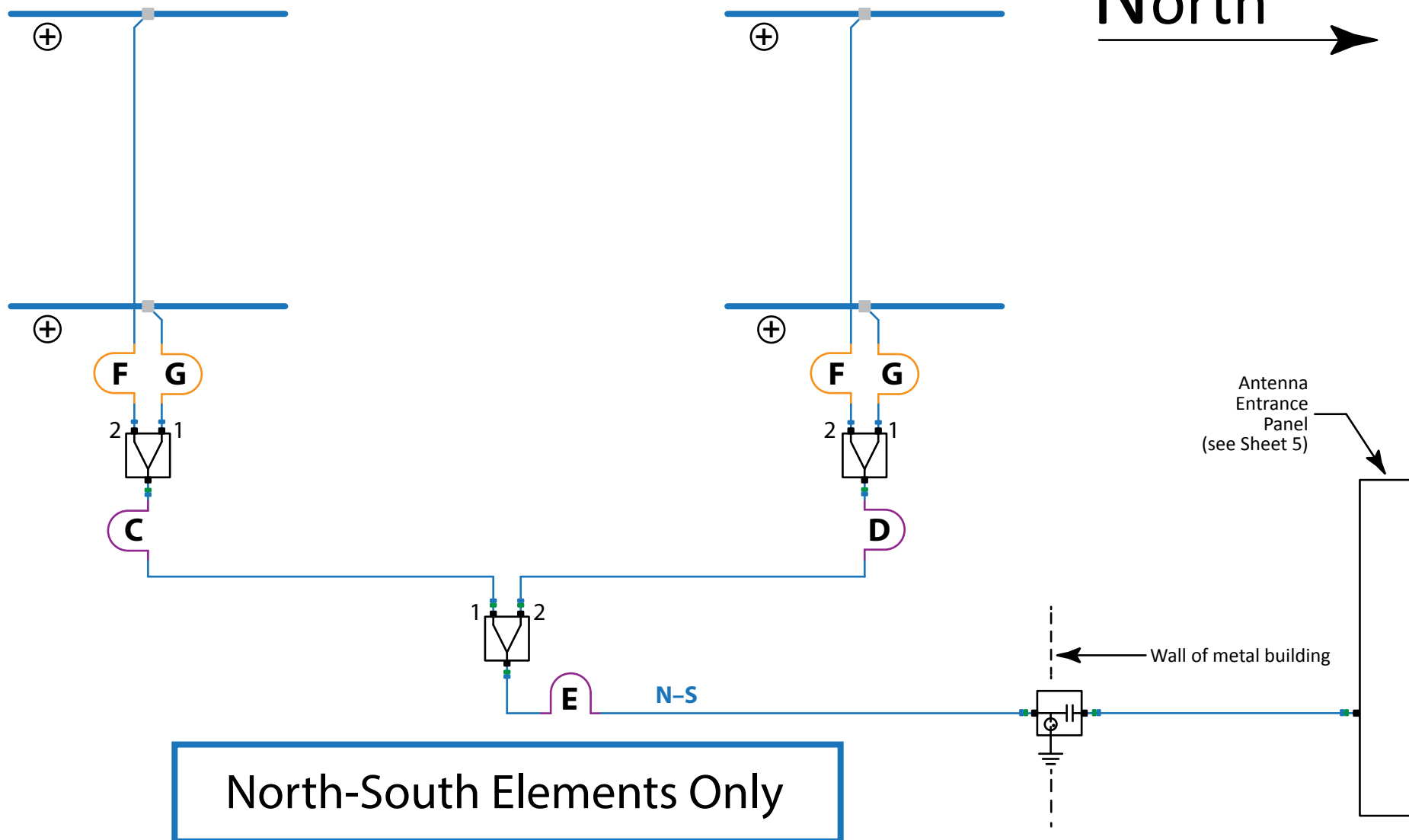

North-South Elements Only

**TFD ARRAY
CONFIGURATION C
CP MODE**

See Sheet 5 for XY to CP 90° Hybrid

Noted coax lengths are in terms of wavelength at 20.1 MHz.

30' folded dipoles, top wire 9'2" height,
8" wire spacing, 32' element spacing,
800 Ω termination resistors, 16:1 baluns.

N-S BW ~10° E-W BW ~20°
for < 3 dB response variance at 24 MHz

AJ4CO OBSERVATORY	AJ4CO Observatory Diagram			
	SIZE A	DATE 15 JAN 2014	PART NUMBER N/A	REV
	SCALE NONE	DRAWN BY DAVE TYPINSKI	SHEET 1 OF 5	

4

3

2

1

TFD Array Beam Steering

Time Delay Cable VoP: **66%** Array elements N-S baseline spacing (feet): **32**
 Array elements E-W baseline spacing (feet): **32**

N-S Offset (degrees)	E-W Offset (degrees)	Delay Cable Lengths (feet & inches)					AZ (degrees)	EL (degrees)
		A (S) / B (N)	C (S) / D (N)	E	F (W) / G (E)	H		
20 N	60 E	7' 2-3/4"	14' 5-1/4"	3' 7-1/4"	18' 3-1/2"	9' 1-3/4"	78	29
20 N	45 E	7' 2-3/4"	14' 5-1/4"	3' 7-1/4"	14' 11-1/4"	7' 5-1/2"	70	43
20 N	30 E	7' 2-3/4"	14' 5-1/4"	3' 7-1/4"	10' 6-3/4"	5' 3-1/4"	58	56
20 N	15 E	7' 2-3/4"	14' 5-1/4"	3' 7-1/4"	5' 5-1/2"	2' 8-3/4"	36	66
20 N	0	7' 2-3/4"	14' 5-1/4"	3' 7-1/4"	0"	0"	0	70
20 N	15 W	7' 2-3/4"	14' 5-1/4"	3' 7-1/4"	5' 5-1/2"	2' 8-3/4"	324	66
20 N	30 W	7' 2-3/4"	14' 5-1/4"	3' 7-1/4"	10' 6-3/4"	5' 3-1/4"	302	56
20 N	45 W	7' 2-3/4"	14' 5-1/4"	3' 7-1/4"	14' 11-1/4"	7' 5-1/2"	290	43
20 N	60 W	7' 2-3/4"	14' 5-1/4"	3' 7-1/4"	18' 3-1/2"	9' 1-3/4"	282	29
<hr/>								
15 N	60 E	5' 5-1/2"	10' 11-1/4"	2' 8-3/4"	18' 3-1/2"	9' 1-3/4"	81	30
15 N	45 E	5' 5-1/2"	10' 11-1/4"	2' 8-3/4"	14' 11-1/4"	7' 5-1/2"	105	44
15 N	30 E	5' 5-1/2"	10' 11-1/4"	2' 8-3/4"	10' 6-3/4"	5' 3-1/4"	115	58
15 N	15 E	5' 5-1/2"	10' 11-1/4"	2' 8-3/4"	5' 5-1/2"	2' 8-3/4"	135	69
15 N	0	5' 5-1/2"	10' 11-1/4"	2' 8-3/4"	0"	0"	180	75
15 N	15 W	5' 5-1/2"	10' 11-1/4"	2' 8-3/4"	5' 5-1/2"	2' 8-3/4"	225	69
15 N	30 W	5' 5-1/2"	10' 11-1/4"	2' 8-3/4"	10' 6-3/4"	5' 3-1/4"	245	58
15 N	45 W	5' 5-1/2"	10' 11-1/4"	2' 8-3/4"	14' 11-1/4"	7' 5-1/2"	255	44
15 N	60 W	5' 5-1/2"	10' 11-1/4"	2' 8-3/4"	18' 3-1/2"	9' 1-3/4"	261	30
<hr/>								
10 N	60 E	3' 8"	7' 4"	1' 10"	18' 3-1/2"	9' 1-3/4"	96	30
10 N	45 E	3' 8"	7' 4"	1' 10"	14' 11-1/4"	7' 5-1/2"	100	45
10 N	30 E	3' 8"	7' 4"	1' 10"	10' 6-3/4"	5' 3-1/4"	107	59
10 N	15 E	3' 8"	7' 4"	1' 10"	5' 5-1/2"	2' 8-3/4"	123	72
10 N	0	3' 8"	7' 4"	1' 10"	0"	0"	180	80
10 N	15 W	3' 8"	7' 4"	1' 10"	5' 5-1/2"	2' 8-3/4"	237	72
10 N	30 W	3' 8"	7' 4"	1' 10"	10' 6-3/4"	5' 3-1/4"	253	59
10 N	45 W	3' 8"	7' 4"	1' 10"	14' 11-1/4"	7' 5-1/2"	260	45
10 N	60 W	3' 8"	7' 4"	1' 10"	18' 3-1/2"	9' 1-3/4"	264	30

AJ4CO
OBSERVATORY

AJ4CO Observatory Diagram

SIZE A	DATE 01 OCT 2014	PART NUMBER N/A	REV
SCALE NONE	DRAWN BY DAVE TYPINSKI	SHEET 2A OF 5	

4

3

2

1

TFD Array Beam Steering

Time Delay Cable VoP: **66%** Array elements N-S baseline spacing (feet): **32**
 Array elements E-W baseline spacing (feet): **32**

N-S Offset (degrees)	E-W Offset (degrees)	Delay Cable Lengths (feet & inches)					AZ (degrees)	EL (degrees)
		A (S) / B (N)	C (S) / D (N)	E	F (W) / G (E)	H		
5 N	60 E	1' 10"	3' 8-1/4"	11"	18' 3-1/2"	9' 1-3/4"	87	30
5 N	45 E	1' 10"	3' 8-1/4"	11"	14' 11-1/4"	7' 5-1/2"	85	45
5 N	30 E	1' 10"	3' 8-1/4"	11"	10' 6-3/4"	5' 3-1/4"	81	60
5 N	15 E	1' 10"	3' 8-1/4"	11"	5' 5-1/2"	2' 8-3/4"	72	74
5 N	0	1' 10"	3' 8-1/4"	11"	0"	0"	360	85
5 N	15 W	1' 10"	3' 8-1/4"	11"	5' 5-1/2"	2' 8-3/4"	288	74
5 N	30 W	1' 10"	3' 8-1/4"	11"	10' 6-3/4"	5' 3-1/4"	279	60
5 N	45 W	1' 10"	3' 8-1/4"	11"	14' 11-1/4"	7' 5-1/2"	275	45
5 N	60 W	1' 10"	3' 8-1/4"	11"	18' 3-1/2"	9' 1-3/4"	273	30
<hr/>								
0	60 E	0"	0"	0"	18' 3-1/2"	9' 1-3/4"	90	30
0	45 E	0"	0"	0"	14' 11-1/4"	7' 5-1/2"	90	45
0	30 E	0"	0"	0"	10' 6-3/4"	5' 3-1/4"	90	60
0	15 E	0"	0"	0"	5' 5-1/2"	2' 8-3/4"	90	75
0	0	0"	0"	0"	0"	0"	180	90
0	15 W	0"	0"	0"	5' 5-1/2"	2' 8-3/4"	270	75
0	30 W	0"	0"	0"	10' 6-3/4"	5' 3-1/4"	270	60
0	45 W	0"	0"	0"	14' 11-1/4"	7' 5-1/2"	270	45
0	60 W	0"	0"	0"	18' 3-1/2"	9' 1-3/4"	270	30
<hr/>								
5 S	60 E	1' 10"	3' 8-1/4"	11"	18' 3-1/2"	9' 1-3/4"	93	30
5 S	45 E	1' 10"	3' 8-1/4"	11"	14' 11-1/4"	7' 5-1/2"	95	45
5 S	30 E	1' 10"	3' 8-1/4"	11"	10' 6-3/4"	5' 3-1/4"	99	60
5 S	15 E	1' 10"	3' 8-1/4"	11"	5' 5-1/2"	2' 8-3/4"	108	74
5 S	0	1' 10"	3' 8-1/4"	11"	0"	0"	180	85
5 S	15 W	1' 10"	3' 8-1/4"	11"	5' 5-1/2"	2' 8-3/4"	252	74
5 S	30 W	1' 10"	3' 8-1/4"	11"	10' 6-3/4"	5' 3-1/4"	261	60
5 S	45 W	1' 10"	3' 8-1/4"	11"	14' 11-1/4"	7' 5-1/2"	265	45
5 S	60 W	1' 10"	3' 8-1/4"	11"	18' 3-1/2"	9' 1-3/4"	267	30



AJ4CO Observatory Diagram

SIZE A	DATE 01 OCT 2014	PART NUMBER N/A	REV
SCALE NONE	DRAWN BY DAVE TYPINSKI	SHEET 2B OF 5	

TFD Array Beam Steering

Time Delay Cable VoP: 66% **Array elements N-S baseline spacing (feet): 32**
Array elements E-W baseline spacing (feet): 32

N-S Offset (degrees)	E-W Offset (degrees)	Delay Cable Lengths (feet & inches)					AZ (degrees)	EL (degrees)
		A (S) / B (N)	C (S) / D (N)	E	F (W) / G (E)	H		
10 S	60 E	3' 8"	7' 4"	1' 10"	18' 3-1/2"	9' 1-3/4"	96	30
10 S	45 E	3' 8"	7' 4"	1' 10"	14' 11-1/4"	7' 5-1/2"	100	45
10 S	30 E	3' 8"	7' 4"	1' 10"	10' 6-3/4"	5' 3-1/4"	107	59
10 S	15 E	3' 8"	7' 4"	1' 10"	5' 5-1/2"	2' 8-3/4"	123	72
10 S	0	3' 8"	7' 4"	1' 10"	0"	0"	180	80
10 S	15 W	3' 8"	7' 4"	1' 10"	5' 5-1/2"	2' 8-3/4"	237	72
10 S	30 W	3' 8"	7' 4"	1' 10"	10' 6-3/4"	5' 3-1/4"	253	59
10 S	45 W	3' 8"	7' 4"	1' 10"	14' 11-1/4"	7' 5-1/2"	260	45
10 S	60 W	3' 8"	7' 4"	1' 10"	18' 3-1/2"	9' 1-3/4"	264	30
<hr/>								
15 S	60 E	5' 5-1/2"	10' 11-1/4"	2' 8-3/4"	18' 3-1/2"	9' 1-3/4"	99	30
15 S	45 E	5' 5-1/2"	10' 11-1/4"	2' 8-3/4"	14' 11-1/4"	7' 5-1/2"	105	44
15 S	30 E	5' 5-1/2"	10' 11-1/4"	2' 8-3/4"	10' 6-3/4"	5' 3-1/4"	115	58
15 S	15 E	5' 5-1/2"	10' 11-1/4"	2' 8-3/4"	5' 5-1/2"	2' 8-3/4"	135	69
15 S	0	5' 5-1/2"	10' 11-1/4"	2' 8-3/4"	0"	0"	180	75
15 S	15 W	5' 5-1/2"	10' 11-1/4"	2' 8-3/4"	5' 5-1/2"	2' 8-3/4"	225	69
15 S	30 W	5' 5-1/2"	10' 11-1/4"	2' 8-3/4"	10' 6-3/4"	5' 3-1/4"	245	58
15 S	45 W	5' 5-1/2"	10' 11-1/4"	2' 8-3/4"	14' 11-1/4"	7' 5-1/2"	255	44
15 S	60 W	5' 5-1/2"	10' 11-1/4"	2' 8-3/4"	18' 3-1/2"	9' 1-3/4"	261	30
<hr/>								
20 S	60 E	7' 2-3/4"	14' 5-1/4"	3' 7-1/4"	18' 3-1/2"	9' 1-3/4"	102	29
20 S	45 E	7' 2-3/4"	14' 5-1/4"	3' 7-1/4"	14' 11-1/4"	7' 5-1/2"	110	43
20 S	30 E	7' 2-3/4"	14' 5-1/4"	3' 7-1/4"	10' 6-3/4"	5' 3-1/4"	122	56
20 S	15 E	7' 2-3/4"	14' 5-1/4"	3' 7-1/4"	5' 5-1/2"	2' 8-3/4"	144	66
20 S	0	7' 2-3/4"	14' 5-1/4"	3' 7-1/4"	0"	0"	180	70
20 S	15 W	7' 2-3/4"	14' 5-1/4"	3' 7-1/4"	5' 5-1/2"	2' 8-3/4"	216	66
20 S	30 W	7' 2-3/4"	14' 5-1/4"	3' 7-1/4"	10' 6-3/4"	5' 3-1/4"	238	56
20 S	45 W	7' 2-3/4"	14' 5-1/4"	3' 7-1/4"	14' 11-1/4"	7' 5-1/2"	250	43
20 S	60 W	7' 2-3/4"	14' 5-1/4"	3' 7-1/4"	18' 3-1/2"	9' 1-3/4"	258	29

AJ4CO
OBSERVATORY

AJ4CO Observatory Diagram

SIZE A	DATE 01 OCT 2014	PART NUMBER N/A	REV
SCALE NONE	DRAWN BY DAVE TYPINSKI	SHEET 2C OF 5	

TFD Array Beam Steering

Time Delay Cable VoP: **66%** Array elements N-S baseline spacing (feet): **32**
 Array elements E-W baseline spacing (feet): **32**

N-S Offset (degrees)	E-W Offset (degrees)	Delay Cable Lengths (feet & inches)					AZ (degrees)	EL (degrees)
		A (S) / B (N)	C (S) / D (N)	E	F (W) / G (E)	H		
25 S	60 E	8' 11"	17' 10-1/4"	4' 5-1/2"	18' 3-1/2"	9' 1-3/4"	105	29
25 S	45 E	8' 11"	17' 10-1/4"	4' 5-1/2"	14' 11-1/4"	7' 5-1/2"	115	42
25 S	30 E	8' 11"	17' 10-1/4"	4' 5-1/2"	10' 6-3/4"	5' 3-1/4"	129	53
25 S	15 E	8' 11"	17' 10-1/4"	4' 5-1/2"	5' 5-1/2"	2' 8-3/4"	150	62
25 S	0	8' 11"	17' 10-1/4"	4' 5-1/2"	0"	0"	180	65
25 S	15 W	8' 11"	17' 10-1/4"	4' 5-1/2"	5' 5-1/2"	2' 8-3/4"	210	62
25 S	30 W	8' 11"	17' 10-1/4"	4' 5-1/2"	10' 6-3/4"	5' 3-1/4"	231	53
25 S	45 W	8' 11"	17' 10-1/4"	4' 5-1/2"	14' 11-1/4"	7' 5-1/2"	245	42
25 S	60 W	8' 11"	17' 10-1/4"	4' 5-1/2"	18' 3-1/2"	9' 1-3/4"	255	29
<hr/>								
30 S	60 E	10' 6-3/4"	21' 1-1/2"	5' 3-1/4"	18' 3-1/2"	9' 1-3/4"	108	29
30 S	45 E	10' 6-3/4"	21' 1-1/2"	5' 3-1/4"	14' 11-1/4"	7' 5-1/2"	120	41
30 S	30 E	10' 6-3/4"	21' 1-1/2"	5' 3-1/4"	10' 6-3/4"	5' 3-1/4"	135	51
30 S	15 E	10' 6-3/4"	21' 1-1/2"	5' 3-1/4"	5' 5-1/2"	2' 8-3/4"	155	58
30 S	0	10' 6-3/4"	21' 1-1/2"	5' 3-1/4"	0"	0"	180	60
30 S	15 W	10' 6-3/4"	21' 1-1/2"	5' 3-1/4"	5' 5-1/2"	2' 8-3/4"	205	58
30 S	30 W	10' 6-3/4"	21' 1-1/2"	5' 3-1/4"	10' 6-3/4"	5' 3-1/4"	225	51
30 S	45 W	10' 6-3/4"	21' 1-1/2"	5' 3-1/4"	14' 11-1/4"	7' 5-1/2"	240	41
30 S	60 W	10' 6-3/4"	21' 1-1/2"	5' 3-1/4"	18' 3-1/2"	9' 1-3/4"	252	29
<hr/>								
35 S	60 E	12' 1-1/4"	24' 2-3/4"	6' 0-3/4"	18' 3-1/2"	9' 1-3/4"	112	28
35 S	45 E	12' 1-1/4"	24' 2-3/4"	6' 0-3/4"	14' 11-1/4"	7' 5-1/2"	125	39
35 S	30 E	12' 1-1/4"	24' 2-3/4"	6' 0-3/4"	10' 6-3/4"	5' 3-1/4"	140	48
35 S	15 E	12' 1-1/4"	24' 2-3/4"	6' 0-3/4"	5' 5-1/2"	2' 8-3/4"	159	53
35 S	0	12' 1-1/4"	24' 2-3/4"	6' 0-3/4"	0"	0"	180	55
35 S	15 W	12' 1-1/4"	24' 2-3/4"	6' 0-3/4"	5' 5-1/2"	2' 8-3/4"	201	53
35 S	30 W	12' 1-1/4"	24' 2-3/4"	6' 0-3/4"	10' 6-3/4"	5' 3-1/4"	220	48
35 S	45 W	12' 1-1/4"	24' 2-3/4"	6' 0-3/4"	14' 11-1/4"	7' 5-1/2"	235	39
35 S	60 W	12' 1-1/4"	24' 2-3/4"	6' 0-3/4"	18' 3-1/2"	9' 1-3/4"	248	28

AJ4CO
OBSERVATORY

AJ4CO Observatory Diagram

SIZE A	DATE 01 OCT 2014	PART NUMBER N/A	REV
SCALE NONE	DRAWN BY DAVE TYPINSKI	SHEET 2D OF 5	

TFD Array Beam Steering

Time Delay Cable VoP: **66%** Array elements N-S baseline spacing (feet): **32**
 Array elements E-W baseline spacing (feet): **32**

N-S Offset (degrees)	E-W Offset (degrees)	Delay Cable Lengths (feet & inches)					AZ (degrees)	EL (degrees)
		A (S) / B (N)	C (S) / D (N)	E	F (W) / G (E)	H		
40 S	60 E	13' 7"	27' 1-3/4"	6' 9-1/2"	18' 3-1/2"	9' 1-3/4"	116	27
40 S	45 E	13' 7"	27' 1-3/4"	6' 9-1/2"	14' 11-1/4"	7' 5-1/2"	130	37
40 S	30 E	13' 7"	27' 1-3/4"	6' 9-1/2"	10' 6-3/4"	5' 3-1/4"	145	44
40 S	15 E	13' 7"	27' 1-3/4"	6' 9-1/2"	5' 5-1/2"	2' 8-3/4"	162	49
40 S	0	13' 7"	27' 1-3/4"	6' 9-1/2"	0"	0"	180	50
40 S	15 W	13' 7"	27' 1-3/4"	6' 9-1/2"	5' 5-1/2"	2' 8-3/4"	198	49
40 S	30 W	13' 7"	27' 1-3/4"	6' 9-1/2"	10' 6-3/4"	5' 3-1/4"	215	44
40 S	45 W	13' 7"	27' 1-3/4"	6' 9-1/2"	14' 11-1/4"	7' 5-1/2"	230	37
40 S	60 W	13' 7"	27' 1-3/4"	6' 9-1/2"	18' 3-1/2"	9' 1-3/4"	244	27
45 S	60 E	14' 11-1/4"	29' 10-1/2"	7' 5-1/2"	18' 3-1/2"	9' 1-3/4"	120	27
45 S	45 E	14' 11-1/4"	29' 10-1/2"	7' 5-1/2"	14' 11-1/4"	7' 5-1/2"	135	35
45 S	30 E	14' 11-1/4"	29' 10-1/2"	7' 5-1/2"	10' 6-3/4"	5' 3-1/4"	150	41
45 S	15 E	14' 11-1/4"	29' 10-1/2"	7' 5-1/2"	5' 5-1/2"	2' 8-3/4"	165	44
45 S	0	14' 11-1/4"	29' 10-1/2"	7' 5-1/2"	0"	0"	180	45
45 S	15 W	14' 11-1/4"	29' 10-1/2"	7' 5-1/2"	5' 5-1/2"	2' 8-3/4"	195	44
45 S	30 W	14' 11-1/4"	29' 10-1/2"	7' 5-1/2"	10' 6-3/4"	5' 3-1/4"	210	41
45 S	45 W	14' 11-1/4"	29' 10-1/2"	7' 5-1/2"	14' 11-1/4"	7' 5-1/2"	225	35
45 S	60 W	14' 11-1/4"	29' 10-1/2"	7' 5-1/2"	18' 3-1/2"	9' 1-3/4"	240	27
50 S	60 E	16' 2-1/4"	32' 4-1/4"	8' 1"	18' 3-1/2"	9' 1-3/4"	125	25
50 S	45 E	16' 2-1/4"	32' 4-1/4"	8' 1"	14' 11-1/4"	7' 5-1/2"	140	33
50 S	30 E	16' 2-1/4"	32' 4-1/4"	8' 1"	10' 6-3/4"	5' 3-1/4"	154	37
50 S	15 E	16' 2-1/4"	32' 4-1/4"	8' 1"	5' 5-1/2"	2' 8-3/4"	167	39
50 S	0	16' 2-1/4"	32' 4-1/4"	8' 1"	0"	0"	180	40
50 S	15 W	16' 2-1/4"	32' 4-1/4"	8' 1"	5' 5-1/2"	2' 8-3/4"	193	39
50 S	30 W	16' 2-1/4"	32' 4-1/4"	8' 1"	10' 6-3/4"	5' 3-1/4"	206	37
50 S	45 W	16' 2-1/4"	32' 4-1/4"	8' 1"	14' 11-1/4"	7' 5-1/2"	220	33
50 S	60 W	16' 2-1/4"	32' 4-1/4"	8' 1"	18' 3-1/2"	9' 1-3/4"	235	25



AJ4CO Observatory Diagram

SIZE A	DATE 01 OCT 2014	PART NUMBER N/A	REV
SCALE NONE	DRAWN BY DAVE TYPINSKI	SHEET 2E OF 5	

4

3

2

1

TFD Array Beam Steering

Time Delay Cable VoP: **66%** Array elements N-S baseline spacing (feet): **32**
 Array elements E-W baseline spacing (feet): **32**

N-S Offset (degrees)	E-W Offset (degrees)	Delay Cable Lengths (feet & inches)					AZ (degrees)	EL (degrees)
		A (S) / B (N)	C (S) / D (N)	E	F (W) / G (E)	H		
55 S	60 E	17' 3-1/2"	34' 7-1/4"	8' 7-3/4"	18' 3-1/2"	9' 1-3/4"	130	24
55 S	45 E	17' 3-1/2"	34' 7-1/4"	8' 7-3/4"	14' 11-1/4"	7' 5-1/2"	145	30
55 S	30 E	17' 3-1/2"	34' 7-1/4"	8' 7-3/4"	10' 6-3/4"	5' 3-1/4"	158	33
55 S	15 E	17' 3-1/2"	34' 7-1/4"	8' 7-3/4"	5' 5-1/2"	2' 8-3/4"	169	35
55 S	0	17' 3-1/2"	34' 7-1/4"	8' 7-3/4"	0"	0"	180	35
55 S	15 W	17' 3-1/2"	34' 7-1/4"	8' 7-3/4"	5' 5-1/2"	2' 8-3/4"	191	35
55 S	30 W	17' 3-1/2"	34' 7-1/4"	8' 7-3/4"	10' 6-3/4"	5' 3-1/4"	202	33
55 S	45 W	17' 3-1/2"	34' 7-1/4"	8' 7-3/4"	14' 11-1/4"	7' 5-1/2"	215	30
55 S	60 W	17' 3-1/2"	34' 7-1/4"	8' 7-3/4"	18' 3-1/2"	9' 1-3/4"	230	24
<hr/>								
60 S	60 E	18' 3-1/2"	36' 7"	9' 1-3/4"	18' 3-1/2"	9' 1-3/4"	135	22
60 S	45 E	18' 3-1/2"	36' 7"	9' 1-3/4"	14' 11-1/4"	7' 5-1/2"	150	27
60 S	30 E	18' 3-1/2"	36' 7"	9' 1-3/4"	10' 6-3/4"	5' 3-1/4"	162	29
60 S	15 E	18' 3-1/2"	36' 7"	9' 1-3/4"	5' 5-1/2"	2' 8-3/4"	171	30
60 S	0	18' 3-1/2"	36' 7"	9' 1-3/4"	0"	0"	180	30
60 S	15 W	18' 3-1/2"	36' 7"	9' 1-3/4"	5' 5-1/2"	2' 8-3/4"	189	30
60 S	30 W	18' 3-1/2"	36' 7"	9' 1-3/4"	10' 6-3/4"	5' 3-1/4"	198	29
60 S	45 W	18' 3-1/2"	36' 7"	9' 1-3/4"	14' 11-1/4"	7' 5-1/2"	210	27
60 S	60 W	18' 3-1/2"	36' 7"	9' 1-3/4"	18' 3-1/2"	9' 1-3/4"	225	22

AJ4CO
OBSERVATORY

AJ4CO Observatory Diagram

SIZE	DATE	PART NUMBER	REV
A	01 OCT 2014	N/A	
SCALE	NONE	DRAWN BY	SHEET
		DAVE TYPINSKI	2F OF 5

4

3

2

1

North



30' folded dipoles,
top wire 9'2" height,
8" wire spacing,
32' element spacing,
800 Ω termination resistors,
16:1 baluns.
N-S HPBW = 25° (est.)
E-W HPBW = 70° (est.)

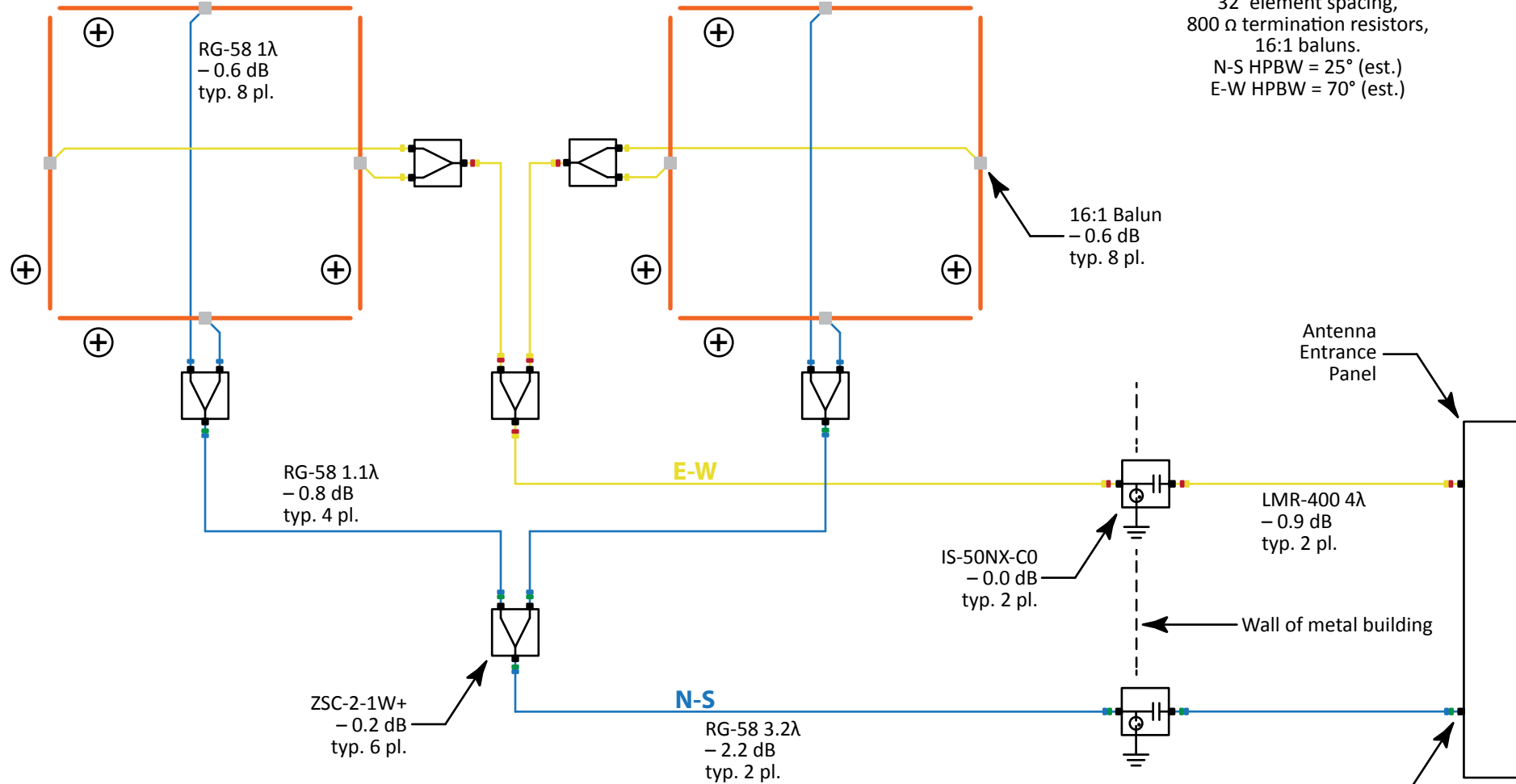

TFD ARRAY CONFIGURATION A X-Y MODE

NOTE: All coax lengths given in terms
of wavelength at 20.1 MHz.



AJ4CO Observatory Diagram

SIZE A	DATE 10 DEC 2013	PART NUMBER N/A	REV
SCALE NONE	DRAWN BY DAVE TYPINSKI	SHEET 3 OF 5	

North
→

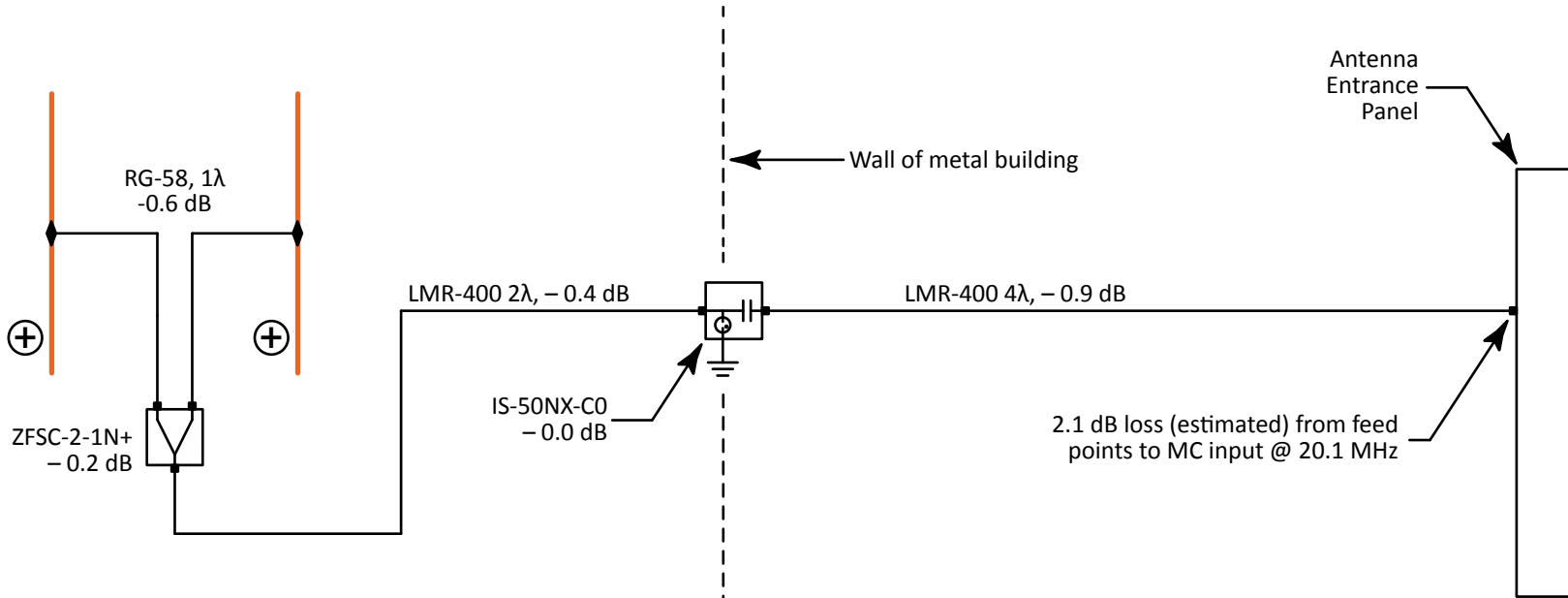

JOVE ARRAY

no phasing,
22'8" dipoles,
11'8" element height
20' element spacing,
HPBW N-S = 71°, E-W = 71°,
7.9 dBi gain (EZNEC).

NOTE: All coax lengths given in terms
of wavelength at 20.1 MHz.

	AJ4CO Observatory Diagram			
	SIZE A	DATE 10 DEC 2013	PART NUMBER N/A	REV
	SCALE NONE	DRAWN BY DAVE TYPINSKI	SHEET 4 OF 5	

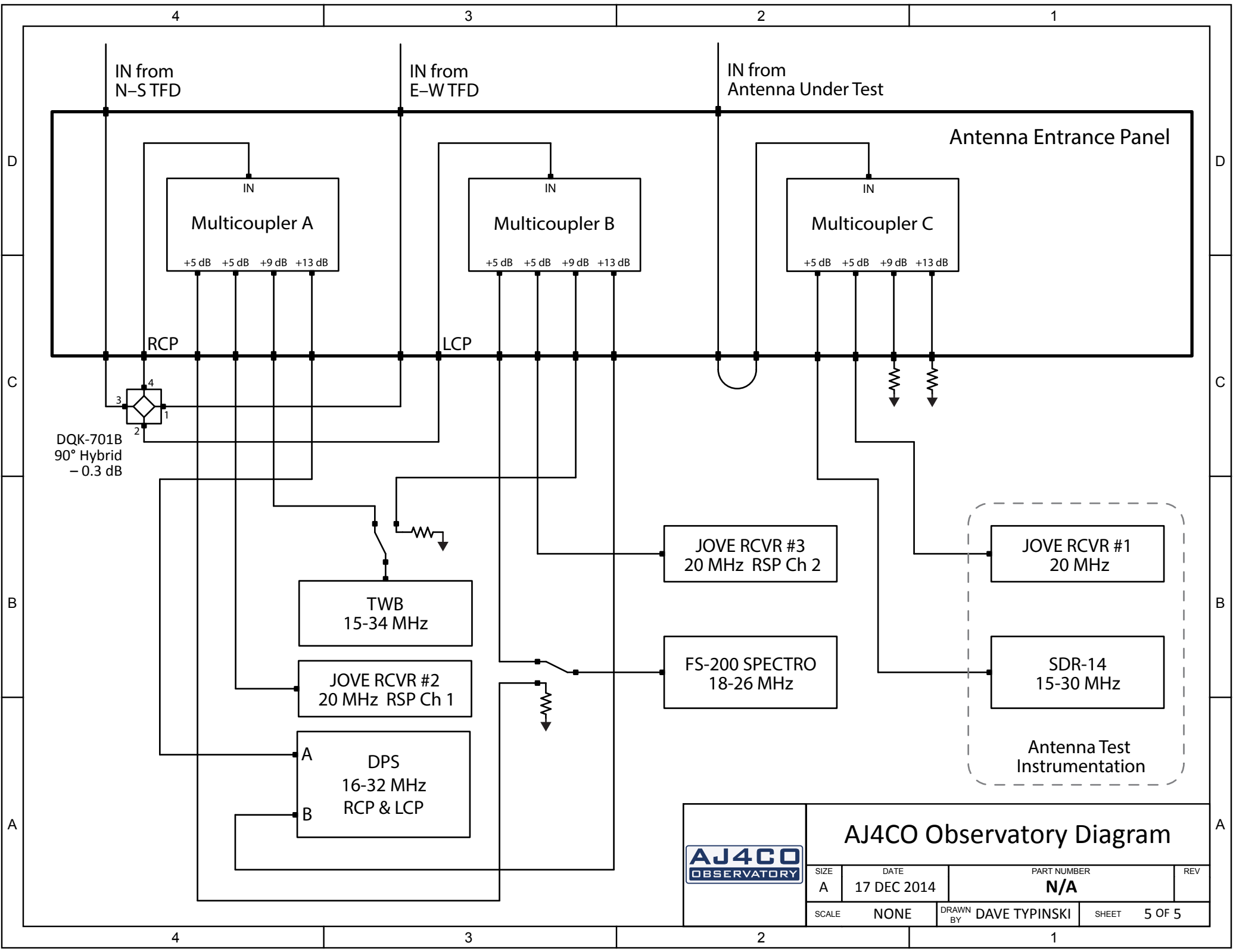

AJ4CO OBSERVATORY	AJ4CO Observatory Diagram			
	SIZE A	DATE 17 DEC 2014	PART NUMBER N/A	REV
	SCALE NONE	DRAWN BY DAVE TYPINSKI	SHEET 5 OF 5	



DATE: 22 OCT 2013
SCALE: 1 mm = 1 ft

AJ4CO
OBSERVATORY

UFRO

AJ400
OBSERVATORY

LGM

